

Irrigation Catalog



AGRICULTURE



Tackling climate
change together

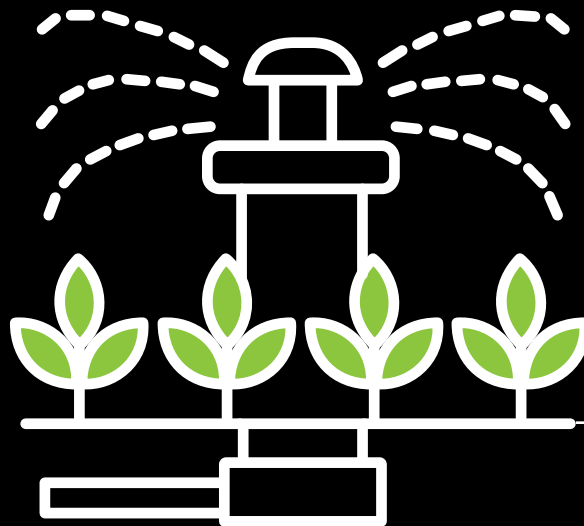

Irrigation

INDEX

CERTIFICATION.....	5
SOLENOID VALVES.....	7
SOLENOID MANIFOLDS.....	25
ISOLATED / FERTILIZER SOLENOIDS.....	29
ELECTRIC & HYDRAULIC VALVES.....	37
ELECTRIC & HYDRAULIC VALVES G500.....	59
CONTROLLERS & SPECIAL VALVES.....	75
OPERATORS & COILS.....	95
TECHNICAL INFORMATION.....	107



CERTIFICATION



THE STANDARDS INSTITUTION OF ISRAEL

ISO 9001:2015

Quality Management System: Design, production, testing and marketing of solenoid valves and automation control equipment



THE STANDARDS INSTITUTION OF ISRAEL

ISO 14001:2015

Environmental Management System: Design, production, testing and marketing of solenoid valves and automation control equipment



THE STANDARDS INSTITUTION OF ISRAEL

ISO 45001:2018

Occupational Health & Safety Management System: Design, production, testing and marketing of solenoid valves and automation control equipment



CE

EC Declaration of Conformity
Complies with the requirements and provisions of the Council Directive 2014/35/EU
Available on selected models only

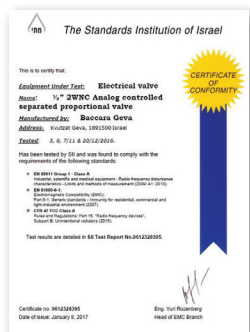

EN55011 Group1 - Class A / EN61000-6-1 / CFR 47 FCC Class A
EMC - SII Certificate of Conformity



UL 429
Standard for electrically operated valves
Only available for GEM-SOL® Coils



FCC
Product certification from The Federal Communications Commission
Available on selected models only



RU (UR)
"Recognized Component Mark" : a quality mark issued by UL and placed on components which are intended to be part of a UL listed product
Available on selected models only

b **BACCARA**[®]
AUTOMATION & CONTROL



SOLENOID VALVES

GEM-FLOW™ G75-A3P	1/8" Latch 2 Way, 3 Way NC, NO	8
GEM-FLOW™ G75-VSA	1/8" Stand-alone Solenoid 3 Way NC, NO	10
GEM-FLOW™ G75-A	1/8", 1/4" 2 Way, 3 Way NC, NO	14
GEM-FLOW™ GALIT	1/8" 3 Way Pilot Operated NC, NO	16
GEM-SOL® A32 (GEM-A)	1/8", 1/4" 2 Way NC, NO	18
GEM-SOL® A32 (GEM-A)	1/8", 1/4" 3 Way NC, NO	20
GEM-SOL® A3P32 (GEM-A3P)	1/8", 1/4" Latch 3 Positioning Manual Override 2, 3 Way NC, NO	22



SOLENOID VALVES

GEM-FLOW™ | G75-A3P

1/8" Latch 2 Way, 3 Way NC, NO

Technical Data

Function	2 Way NC, 3 Way NC, NO
Ports size	1/8" BSP & NPT
Orifice size	2.6 mm
Pressure range	NC 2 Way: 10 bar NC 3 Way: 8 bar NO 3 Way: 10 bar
Temperature range	Fluid: 5°C to 50°C (no freezing) Ambient: -10°C to 50°C
Materials in contact with media	Manual override: Plastic (Reinforced Nylon) NO: Red NC: Green Main Valve: UV Stabilized - Reinforced Nylon 6 30% GF Solenoid Operator: Stainless Steel AISI 300 & 400 series Seals: NBR
Mounting	2 x Ø6 mm holes
Manual override	3 positions (Open/Auto/Close)
Media	Air, water
Coil voltage	Latch
Switching time	40-60 msec
Electric connection	22AWG cable
Standard protection class	IP66

* Can only be operated with supplied coil

* Available with a manifold bracket upon request.
Please contact our technical sales department



Latch Coil Resistance vs Input Voltage Recommendations chart

Resistance [Ω]	Input voltage range [V]
1	8 - 12
4	12 - 18
9	18 - 24

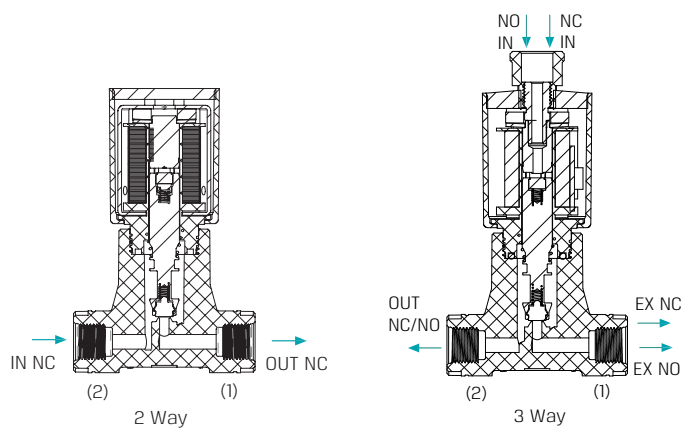

GEM-FLOW™ | G75-A3P | 1/8" Latch 2 Way, 3 Way NC, NO

Dimensions

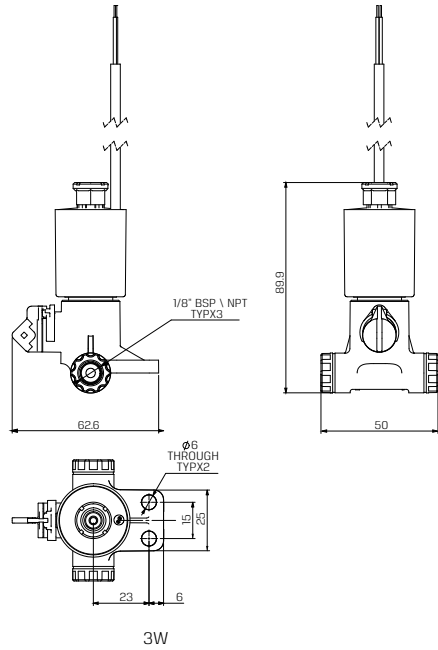
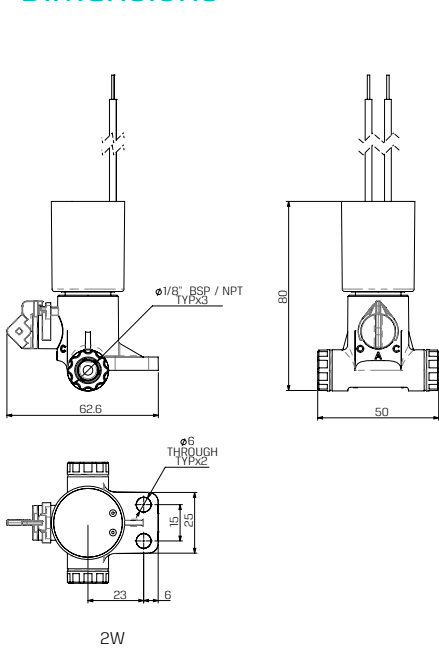

Manual Override Operation

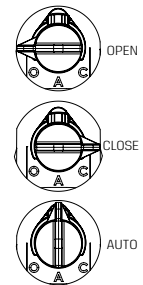

To manually open the valve:
turn selector switch to OPEN

NO: To change from OPEN to AUTO:
turn the selector switch to AUTO

NC: To change from OPEN to AUTO:
turn the selector switch to CLOSE,
and then to AUTO

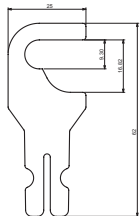

Mounting Bracket
Can be ordered separately
PN 5940610527

How to Order

G75-A3P	TYPE	PORT	FUNCTION ⁽¹⁾	ORIFICE	LATCH TYPE ⁽²⁾	WIRES					
with flange	1	1/8" BSP	10	2W NC	1	2.6	5a	1Ω	PA	two	Null
			11	3W NC	3	4Ω	PB	three	a		
		1/8" NPT	11	3W NC	3	9Ω	PC				
					3W NO	4					

Example: **G75-A3P-11015a-PA**

GEM-FLOW™ G75-A3P, with flange, 1/8" BSP, 2W NC, 2.6 orifice, 1Ω latch with two wires

(1) To order NC configuration, please consult with our technical sales department

(2) Refer to Latch Coil Resistance vs Input Voltage Recommendations chart

* To order valves manufactured according to your specific requirements, please contact our technical sales department

SOLENOID VALVES

GEM-FLOW™ | G75-VSA

1/8" Stand-alone Solenoid 3 Way NC, NO

Technical Data

Function	3 Way NC, NO
Ports size	1/8" BSPT & NPT
Orifice size	1.8 mm
Pressure range	0 to 8 bar
Switching time	30-50 ms
Temperature range	Fluid: 0°C to 50°C (no freezing) Ambient: -10°C to 50°C
Materials in contact with media	Manual override: Plastic (Reinforced Nylon) Main Valve: Plastic (Reinforced Nylon & POM) Solenoid Operator: Stainless Steel AISI 300 & 400 series Seals: EPDM
Mounting	Lock nut on the bottom COM port
Manual override	Latch: 3 position latch: Auto, Close, Open AC: 2 position: Auto, Open
Media	Air, water
Coil voltage	Latch, AC (according to table)
Standard protection class	IP66

* Can **only** be operated with supplied coil



PORT	NO	NC
1	Exhaust	Pressure
3	Pressure	Exhaust
COM	Out	Out

Voltage & Current

AC & DC

Solenoid	Inrush [A]	Holding [A]
24VAC-50 Hz	0.33	0.21

Latch Coil Resistance vs Input Voltage

Recommendations chart

Resistance [Ω]	Input voltage range [V]
4	6 - 9
9	12 - 14
12	14 - 16
23	18 - 21

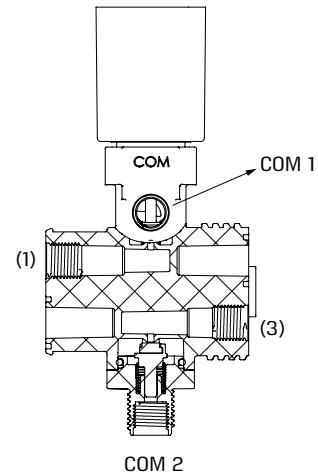

GEM-FLOW™ | G75-VSA | 1/8" Stand-alone Solenoid 3 Way NC, NO

Dimensions

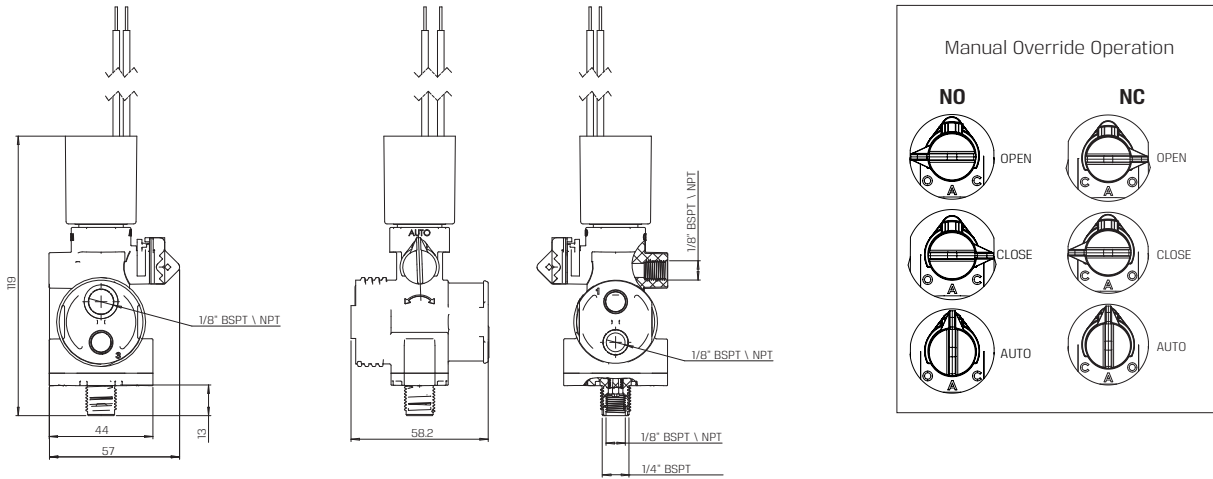

How to Order

G75-VSA	BODY	PORT	FUNCTION	MANUAL OVERRIDE	ORIFICE	SEALS	TYPE	OUTLET ⁽³⁾	WIRES
	Plastic 4	1/8" BSPT 10	3W NC 3	Plastic 1	1.8 3a	EPDM E	24VAC-50Hz ⁽¹⁾ S1	COM 1 1	two Null
		1/8" NPT 11	3W NO 4				4Ω ⁽²⁾ SB	COM 2 2	three ⁽⁴⁾ a
							9Ω ⁽²⁾ SC		
							12Ω ⁽²⁾ SD		
							23Ω ⁽²⁾ S6		

Example: G75-VSA-410313aE-SB1

GEM-FLOW™ G75-VSA stand-alone solenoid, plastic, 1/8" BSPT, 3W NC, plastic manual override, 1.8 orifice, EPDM seals, 4Ω latch, COM 1 outlet, two wires

- (1) Refer to Voltage & Current AC & DC
- (2) Refer to Latch Coil Resistance vs Input Voltage | Recommendations chart
- (3) A plug will be fitted on the other outlet port
- (4) Latch only

* To order valves manufactured according to your specific requirements, please contact our technical sales department

SOLENOID VALVES

GEM-FLOW™ | G75-A

1/8", 1/4" 2 Way, 3 Way NC, NO

Technical Data

Function	2 Way, 3 Way NC, NO
Ports size	1/8" and 1/4" BSP & NPT
Orifice size	See table
Pressure range	See table
Temperature range	Fluid: 5°C to 50°C (no freezing) Ambient: -10°C to 50°C
Materials in contact with media	Manual override: Plastic (Reinforced Nylon) Main Valve: Brass or Plastic (Reinforced Nylon) Solenoid Operator: Stainless Steel AISI 300 & 400 series Seals: EPDM
Coil voltage	• Voltage and power consumption - see table
Standard protection class	IP66

* Available with a manifold bracket upon request.
Please contact our technical sales department

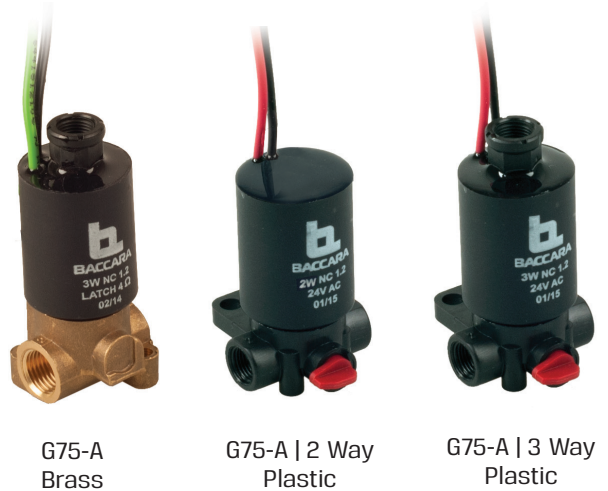

G75-A
Brass

G75-A | 2 Way
Plastic

G75-A | 3 Way
Plastic

Latch Coil Resistance vs Input Voltage

Recommendations chart

Resistance [Ω]	Input voltage range [V]
4	6 - 9
9	12 - 14
12	14 - 16
23	18 - 21

Max. Pressure (bar)

Function	Orifice (mm)	AC	DC	DC Latch
2 Way NC	up to 2.0	12	12	12
3 Way NC	1	16	12	16
	1.2	11	9	11
	1.6	6	5	6
3 Way NO	1.0	16	16	16
	1.2	12	12	12
	1.6	10	10	10

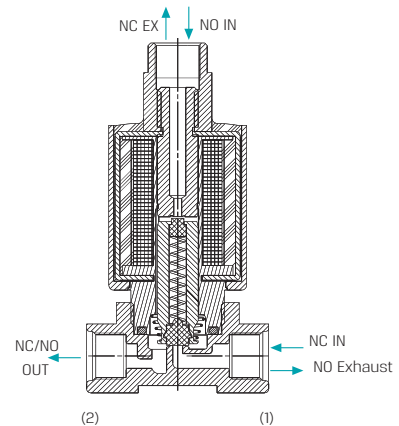

Voltage & Current

AC & DC

Solenoid	Voltage	Inrush [A]	Holding [A]
2 Way 50 Hz	V +10% n-20%	0.3	0.19
2 Way 60 Hz		0.2	0.14
3 Way 50/60 Hz *		0.125	0.125
DC		4.5W	

* Except 24V AC without Diode

Voltage & Power Consumption

V	AC (W)	DC (W)
	50 Hz	
2	2	4.5
12	•	•
24	•	•
110	• 2 Way only	

* Available options

GEM-FLOW™ | G75-A | 1/8", 1/4" 2 Way, 3 Way NC, NO

Dimensions

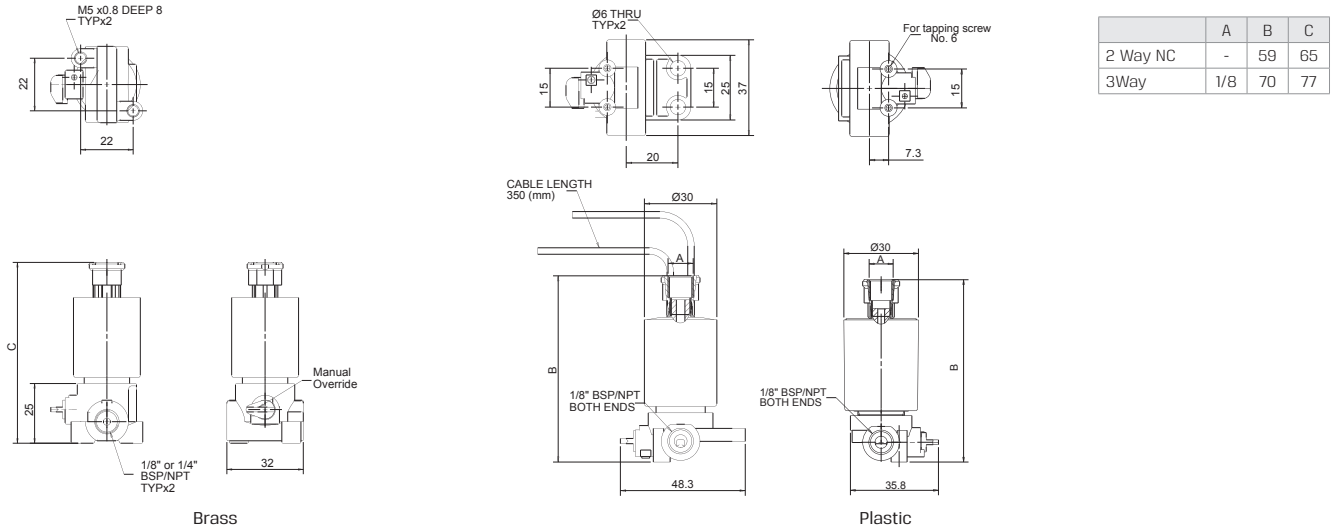

How to Order

G75-A	TYPE	PORT	FUNCTION	MANUAL OVERRIDE	ORIFICE	VOLTAGE ⁽³⁾	WIRES						
with flange	1	1/8" BSP	10	2W NC	1	None	0	1.0 ⁽¹⁾	1	24V AC	1	two	null
Brass	3	1/8" NPT	11	3W NC	3	Plastic ⁽²⁾	1	1.2	2	24V AC w/out Diode ⁽⁴⁾	1R	three ⁽⁵⁾	a
		1/4" BSP ⁽¹⁾	20	3W NO	4			1.6	3	12V AC	3		
		1/4" NPT ⁽¹⁾	21					2.0 ⁽¹⁾	4	12V DC	4		
										24V DC	5		
										23Ω	6		
										110V AC	7		
										4Ω	B		
										9Ω	C		
										12Ω	D		

Example: **G75-A-110302-1**

GEM-FLOW™ G75-A with flange, 1/8" BSP, 3W NC, no manual override, 1.2 orifice, 24V AC coil, two wires

- (1) Brass only
- (2) Recommended for AC and continuous DC only
- (3) For Latch: Refer to Latch Coil Resistance vs Input Voltage | Recommendations chart
- (4) 3W NO 1.6 mm: Max pressure is 8 bars
- (5) For Latch only

* To order valves manufactured according to your specific requirements, please contact our technical sales department

SOLENOID VALVES

GEM-FLOW™ | GALIT

1/8" 3 Way Pilot Operated NC, NO

Technical Data

Function	3 Way NC, NO
Ports size	1/8" BSP & NPT
Orifice size	5mm
Pressure range	1 to 10 bar
Temperature range	Fluid: 5°C to 50°C (no freezing) Ambient: -10°C to 50°C
Materials in contact with media	Main Valve: Plastic (Reinforced Nylon) Solenoid Operator: Stainless Steel 300 & 400 series Seals: NBR Spring: Stainless Steel AISI 300 series
Manual override	Manual override with 3 positions: • AUTO - for automatic operation (valve is open when solenoid is energized) • MANUAL - valve is kept open • CLOSE - valve is kept closed
Solenoid	Assembled with 3W NO 1.2mm G75 operator
Coil voltage	• Voltage and power consumption - see table
Standard protection class	IP66

* Available with a manifold bracket upon request.
Please contact our technical sales department



Voltage & Current

AC & DC

Solenoid	Voltage	Inrush [A]	Holding [A]
2 Way 50 Hz	V +10% -20%	0.3	0.19
2 Way 60 Hz		0.2	0.14
3 Way 50/60 Hz *		0.125	0.125
DC		4.5W	

* Except 24V AC without Diode

Voltage & Power Consumption

	AC (W) 50 Hz	DC (W)
V	2	4.5
12	•	•
24	•	•

• Available options

Latch Coil Resistance vs Input Voltage

Recommendations chart

Resistance [Ω]	Input voltage range [V]
4	6 - 9
9	12 - 14
12	14 - 16
23	18 - 21

GEM-FLOW™ | GALIT | 1/8" 3 Way Pilot Operated NC, NO

Dimensions

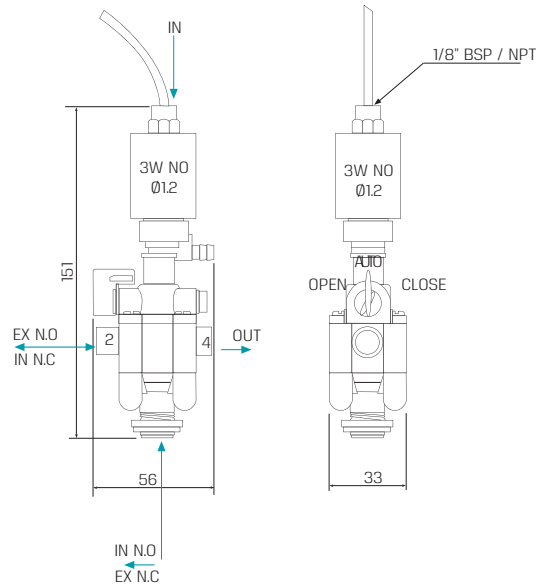

How to Order

GALIT	-	PORT	VOLTAGE ⁽¹⁾		MOUNTING BRACKET		WIRES	
		1/8" BSP	10	24V AC	1	without	0	two null
		1/8" NPT	11	24V AC w/out Diode	1R	with	1	three ⁽²⁾ a
				12V AC	3			
				12V DC	4			
				24V DC	5			
				23Ω	6			
				4Ω	B			
				9Ω	C			
				12Ω	D			

Example: GALIT-1011

GEM-FLOW™ GALIT pilot operated, 1/8" BSP, 24V AC with mounting bracket, two wires

(1) For Latch: Refer to Latch Coil Resistance vs Input Voltage | Recommendations chart

(2) For Latch only

* To order valves manufactured according to your specific requirements, please contact our technical sales department

SOLENOID VALVES

GEM-SOL® | A32 (GEM-A)

1/8", 1/4" 2 Way NC, NO

Technical Data

Function	2 Way NC, NO
Ports size	1/8" and 1/4" BSP & NPT
Orifice size	See table
Pressure range	<ul style="list-style-type: none"> See table Valves for pressure higher than 25 bar cannot be supplied with manual override
Kv (l/min)	See table
Temperature range	Fluid: -10°C to 80°C (no freezing) Ambient: -10°C to 50°C
Materials in contact with media	Manual override: Plastic (Reinforced Nylon), Brass screw or Brass finger knob, Stainless Steel for Stainless Steel valves (1) Plastic manual override: Maximum pressure: 16 bar (2) Manual override is unavailable in 2 Way NO through base applications Main Valve: Brass or Stainless Steel AISI 316 Solenoid Operator: Stainless Steel AISI 300 & 400 series Seals: NBR, FKM, EPDM, FFKM, PTFE
Media	Air, water, oil
Coil voltage	<ul style="list-style-type: none"> Voltage and power consumption - see table All Baccara coil voltages are ± 10% of nominal
Standard protection class	IP65 with connector * Option: IP68 (please refer to GEM-BP Coil)

- Latch valves are available upon request
- Available with a manifold bracket upon request. Please contact our technical sales department

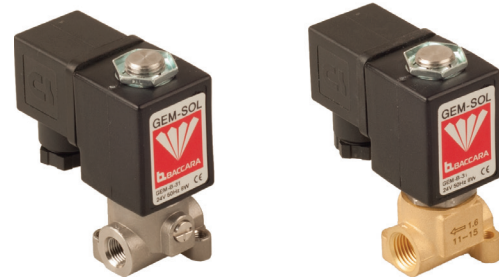

Stainless Steel

Brass

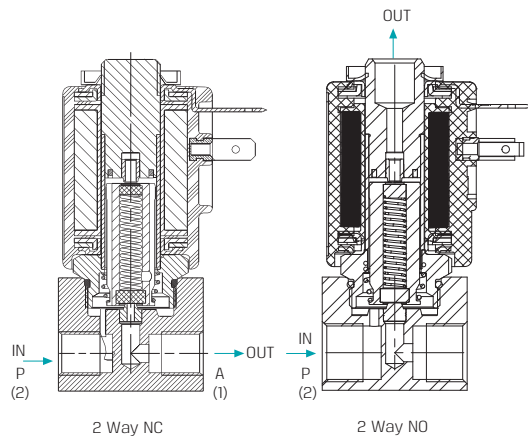

Max. Pressure (bar) 2 Way NC

Coil Current/Power	Orifice (mm)						
	0.8	1.2	1.6	2.0	2.4	3.0	4.0
ADC *	60	50	35	20	15	10	5
AC8W, DC/10W	80	80	60	38	30	18	10
AC5.5W	80	60	40	28	20	15	6
AC2.5W	60	50	35	20	15	9	5
DC5.5W	60	30	18	12	9	6	3
DC3.5W	40	20	12	8	6	4	2
Flow factor Kv(l/min)	0.5	1.1	1.7	2.5	3.5	4.5	5

Max. Pressure (bar) 2 Way NO

Coil Current/Power	Orifice (mm)					
	0.8	1.2	1.6	2.0	2.4	3.0
ADC *	25	25	25	20	15	10
Flow factor Kv(l/min)	0.5	1.1	1.4	2.5	3.0	3.5

* ADC valves are only suitable for use with AC8W or DC10W coils

Voltage & Power Consumption

V	AC (W)						DC (W)		
	50 Hz			60 Hz			10	5.5	3.5
6							•	•	•
12	•			•			•	•	•
24	•	•	•	•	•	•	•	•	•
48	•			•			•		
110	•			•	•		•		
120	•			•	•				
220	•	•	•	•			•		
230	•	•		•	•				
240	•			•			•		

Available options

- Standard
- Special

GEM-SOL® | A32 (GEM-A) | 1/8", 1/4" 2 Way NC, NO

Dimensions

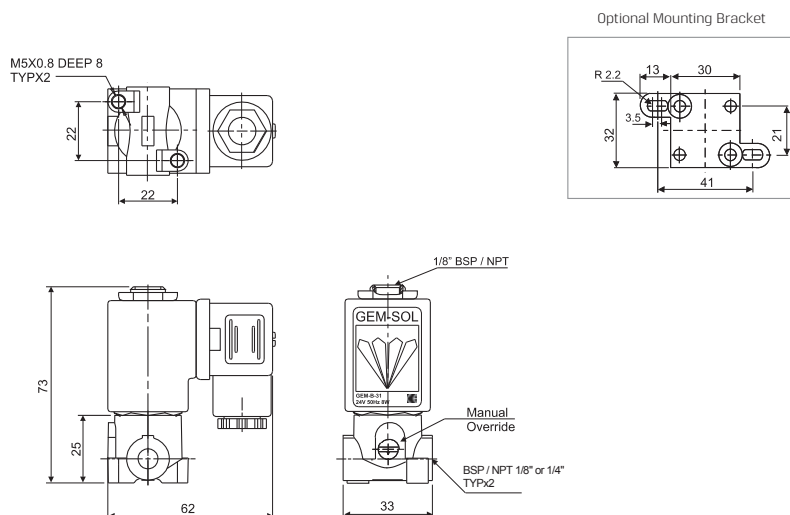

How to Order

* For available options, please refer to VOLTAGE & POWER CONSUMPTION table

GEM-A	BODY	PORT	FUNCTION	ORIFICE	SEALS	MANUAL OVERRIDE	VOLTAGE	POWER	CONNECTOR
Brass	2	1/8" BSP	10 2W NC	1 0.8	1 NBR	N None	0 without coil	0 No coil	0 with
SST	3	1/8" NPT	11 2W NO * 2	1.2	2 FFKM *	V Plastic * (3)	6 ⁽⁴⁾	1 AC8W 50Hz	1 with LED
		1/4" BSP	20 2WNO-through base ⁽¹⁾	1.6	3 EPDM	E Slot	12	2 AC8W 60Hz	2 flying leads coil *
		1/4" NPT	21	2.0	4 FFKM *⁽²⁾	K Knob *	24	3 DC 10W	3 with 1/2" Hub
				2.4	5 PTFE *	T	48	4 AC 5.5W 50Hz	4 surge protection with LED *
				3.0 *	6		110	5 AC 5.5W 60Hz	5 connector with moulded cable
				4.0 *	7		120	6 AC 2.5W 50/60Hz	6 other *
							220	7A DC 5.5W	7
							230	7 DC 3.5W	8
							240	8	8
									Latch/other * ⁽⁵⁾ 9

* SPECIAL OPTIONS | Extended lead times, Non-stock items, MOQ may be applicable

Example : GEM-A-21015N2-331

GEM-SOL® A32 (GEM-A) direct operated, Brass, 1/8"BSP, 2W NC, 2.4 orifice, NBR, slot manual override, 24VDC 10W with connector

- (1) Option 2a : manual override is not available
- (2) FFKM O-ring is available only upon request. When ordering FFKM seals, please consult with our technical sales department about O-ring compound
- (3) Maximum pressure : 16 bar
- (4) DC only
- (5) For specifying Latch type coil, please refer to A3P32 (GEM-A3P) valve - How to Order table

* Note: When ordering without coil, please define what current and pressure rating is needed (DC, AC or ADC), otherwise an ADC valve will be supplied

* To order valves manufactured according to your specific requirements, please contact our technical sales department

SOLENOID VALVES

GEM-SOL® | A32 (GEM-A)

1/8", 1/4" 3 Way NC, NO

Technical Data

Function	3 Way NC, NO
Ports size	1/8" and 1/4" BSP & NPT
Orifice size	See table
Pressure range	<ul style="list-style-type: none"> See table Valves for pressure higher than 25 bar cannot be supplied with manual override
Kv (l/min)	See table
Temperature range	Fluid: -10°C to 80°C (no freezing) Ambient: -10°C to 50°C
Materials in contact with media	Manual override: Plastic (Reinforced Nylon), Brass screw or Brass finger knob, Stainless Steel for Stainless Steel valves (1) Plastic manual override: Maximum pressure: 16 bar (2) Manual override is unavailable in 3 Way NO through base applications Main Valve: Brass or Stainless Steel AISI 316 Solenoid Operator: Stainless Steel AISI 300 & 400 series Seals: NBR, FKM, EPDM, FFKM, PTFE
Media	Air, water, oil
Coil voltage	<ul style="list-style-type: none"> Voltage and power consumption - see table All Baccara coil voltages are ± 10% of nominal
Standard protection class	IP65 with connector * Option: IP68 (please refer to GEM-BP Coil)

- Latch valves are available upon request
- * Available with a manifold bracket upon request. Please contact our technical sales department

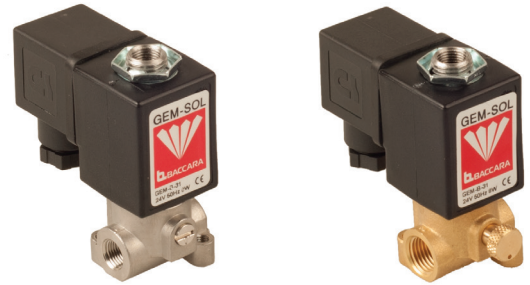

Stainless Steel

Brass

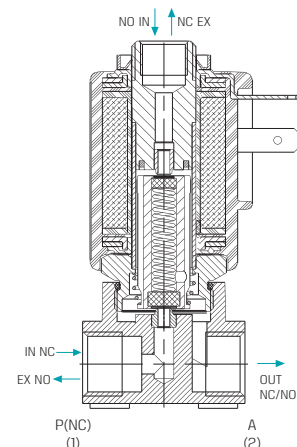

Max. Pressure (bar) 3 Way NC

Coil Current/Power	Orifice (mm)					
	0.8	1.2	1.6	2.0	2.4	3.0
ADC *	23	20	15	10	8	5.5
AC8W, DC10W	35	30	17	14	10	6
AC5.5W	23	20	15	10	8	5.5
AC2.5W DC5.5W DC3.5W	20	16	10	9	5	4
Flow factor Kv(l/min)	0.6	1.1	1.7	2.5	3.5	4.5

Max. Pressure (bar) 3 Way NO

Coil Current/Power	Orifice (mm)					
	0.8	1.2	1.6	2.0	2.4	3.0
ADC *	25	20	15	11	8	6
AC/8W DC/10W	30	22	17	12	10	7
AC/5.5W,DC/5.5W	25	20	15	11	8	6
AC/2.5W,DC/3.5W	20	18	12	8	6	4
Flow factor Kv(l/min)	0.6	1	1.4	2.2	3.0	3.5

* ADC valves are only suitable for use with AC8W or DC10W coils.

Voltage & Power Consumption

V	AC (W)						DC (W)		
	50 Hz			60 Hz			10	5.5	3.5
6							•	•	•
12	•			•			•	•	•
24	•	•		•	•	•	•	•	•
48	•			•			•		
110	•			•	•		•		
120	•			•	•				
220	•	•		•			•		
230	•	•		•	•				
240	•			•			•		

Available options

- Standard
- Special

GEM-SOL® | A32 (GEM-A) | 1/8", 1/4" 3 Way NC, NO

Dimensions

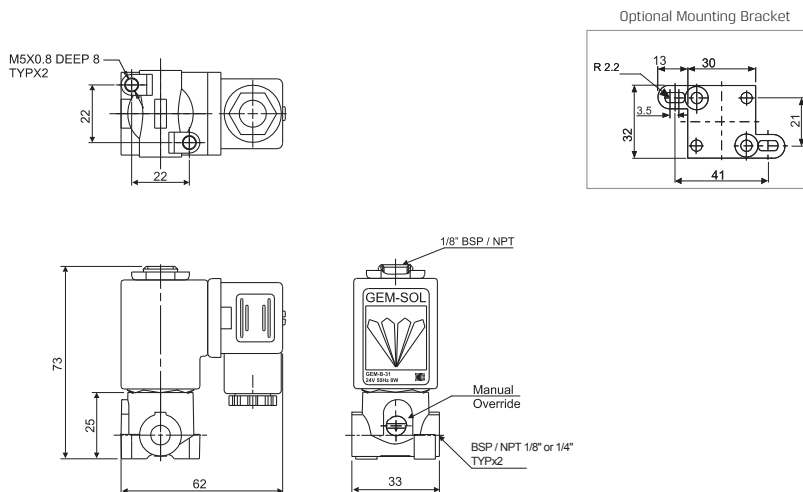

How to Order

* For available options, please refer to VOLTAGE & POWER CONSUMPTION table

GEM-A	BODY	PORT	FUNCTION	ORIFICE	SEALS	MANUAL OVERRIDE	VOLTAGE	POWER	CONNECTOR
Brass	2	1/8" BSP	10 3W NC	3 0.8	1 NBR	N None	0 without coil	0 No coil	0 with
SST	3	1/8" NPT	11 3W NO * 4	1.2	2 FKM *	V Plastic * (3) 1	6 (4)	1 AC8W 50Hz	1 with LED
		1/4" BSP	20 3WNO (1) through base* 4a	1.6	3 EPDM	E Slot	2	2 AC8W 60Hz	2 flying leads coil *
		1/4" NPT	21	2.0	4 FFKM *(2) K	Knob * 3	24	3 DC 10W	3 with 1/2" Hub
				2.4	5 PTFE * T		48	4 AC 5.5W 50Hz	4 surge protection with LED *
				3.0 *	6		110	5 AC 5.5W 60Hz	5 connector with moulded cable
							120	6 AC 2.5W 50/60Hz	6 other *
							220	7A DC 5.5W	7
							230	7 DC 3.5W	8
							240	8	8
									Latch/other * (5) 9

* SPECIAL OPTIONS | Extended lead times, Non-stock items, MOQ may be applicable

Example : GEM-A-21035N2-331

GEM-SOL® A32 (GEM-A) direct operated, Brass, 1/8" BSP, 3W NC, 2.4 orifice, NBR, slot manual override, 24VDC 10W with connector

- (1) Option 4a : manual override is not available
- (2) FFKM O-ring is available only upon request. When ordering FFKM seals, please consult with our technical sales department about O-ring compound
- (3) Maximum pressure : 16 bar
- (4) DC only
- (5) For specifying Latch type coil, please refer to A3P32 (GEM-A3P) valve - How to Order table

* Note: When ordering without coil, please define what current and pressure rating is needed (DC, AC or ADC), otherwise an ADC valve will be supplied

* To order valves manufactured according to your specific requirements, please contact our technical sales department

SOLENOID VALVES

GEM-SOL® | A3P32 (GEM-A3P)

Latch 3 positioning manual override
2 Way, 3 Way NC, NO

Technical Data

Function	2 Way, 3 Way NC, NO
Ports size	1/8" and 1/4" BSP & NPT
Orifice size	See table
Pressure range	See table
Kv (l/min)	See table
Temperature range	Fluid: -10°C to 80°C (no freezing) Ambient: -10°C to 50°C
Materials in contact with media	Manual override: Plastic (Reinforced Nylon) Main Valve: Brass Solenoid Operator: Stainless Steel AISI 300 & 400 series Seals: NBR, FKM, EPDM, FFKM
Media	Air, water, oil
Coil type	Latch
Standard protection class	IP65 with connector * Option: IP68 (please refer to GEM-BP Coil)

* Available with a manifold bracket upon request.
Please contact our technical sales department



Max. Pressure (bar) 2 Way NC

Orifice (mm)	0.8	1.2	1.6	2.0	2.4	3.0	4.0
Pressure (bar)	16	16	16	16	16	16	8
Flow factor Kv(l/min)	0.5	1.1	1.7	2.5	3.5	4.5	5

Max. Pressure (bar) 2 Way NO

Orifice (mm)	0.8	1.2	1.6	2.0	2.4	3.0
Pressure (bar)	16	16	16	16	15	10
Flow factor Kv(l/min)	0.5	1.1	1.7	2.5	3.5	4.5

Max. Pressure (bar) 3 Way NC

Orifice (mm)	0.8	1.2	1.6	2.0	2.4	3.0
Pressure (bar)	16	16	16	14	9	5
Flow factor Kv(l/min)	0.5	1.1	1.7	2.5	3.5	4.5

Max. Pressure (bar) 3 Way NO

Orifice (mm)	0.8	1.2	1.6	2.0	2.4	3.0
Pressure (bar)	16	16	16	12	10	7
Flow factor Kv(l/min)	0.5	1.1	1.7	2.5	3.5	4.5

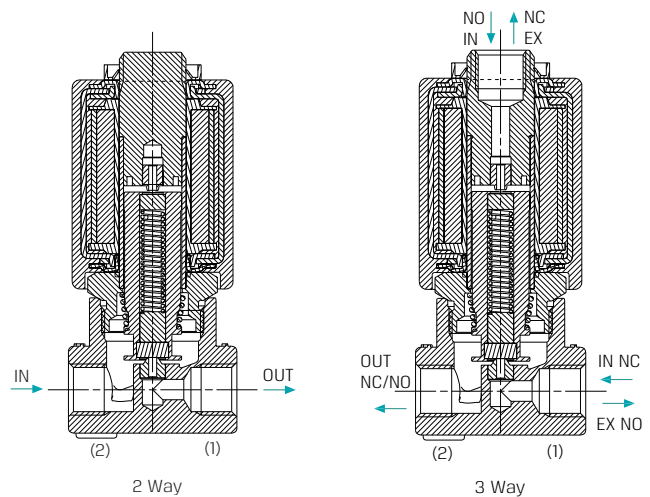

GEM-SOL® | A3P32 (GEM-A3P) | Latch 3 positioning manual override 2 Way, 3 Way NC, NO

Dimensions

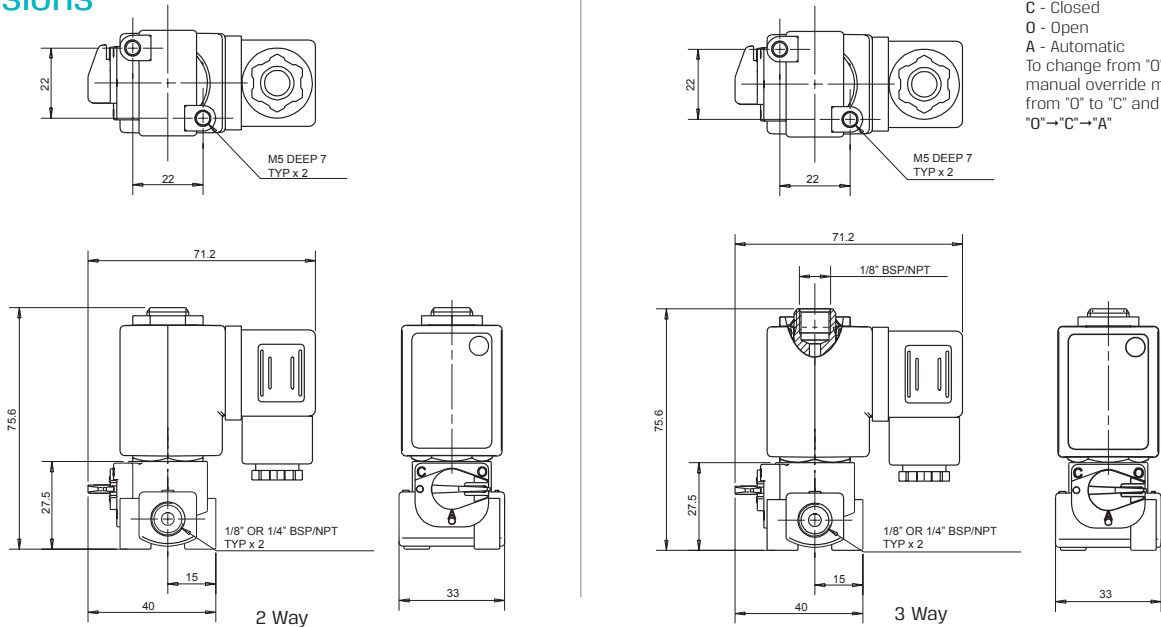

How to Order

GEM-A3P	BODY	PORT	FUNCTION	ORIFICE	SEALS	LATCH TYPE ⁽¹⁾		CONNECTOR						
						Ω	Code	Code	Notes					
-	Brass	2	1/8" BSP	10	2W NC	1	0.8	1	NBR	N	2Ω	LDO	with	1
			1/8" NPT	11	2W NO	2	1.2	2	FKM	V	5Ω	IL	flying leads coil *	4
		1/4" BSP	20	3W NC	3	1.6	3	EPDM	E	13Ω	EL	with 1/2" Hub	5	
		1/4" NPT	21	3W NO	4	2.0	4	FFKM	K	20Ω	OL	connector with moulded cable	7	
					2.4	5			53Ω	DL	other	9		
					3.0	6								
					4.0	7								

* SPECIAL OPTIONS | Extended lead times, Non-stock items, MOQ may be applicable

Example: GEM-A3P-21015N-LD01

GEM-SOL® A3P32 (GEM-A3P) latch 3 positioning manual override, Brass, 1/8" BSP, 2W NC, 2.4 orifice, NBR, 2Ω latch with connector

(1) Choose latch type according to which latch system you have

* To order valves manufactured according to your specific requirements, please contact our technical sales department

b **BACCARA**[®]
AUTOMATION & CONTROL



SOLENOID MANIFOLDS

GEM-FLOW™ G75-VM	Modular Manifold.....	26
--------------------	-----------------------	----



SOLENOID MANIFOLDS

GEM-FLOW™ | G75-VM

Modular Manifold

Technical Data

Function	3 Way NC, NO
Orifice size	1.8 mm
Pressure range	0 to 8 bar
Temperature range	Fluid: 0°C to 50°C (no freezing) Ambient: -10°C to 50°C
Materials in contact with media	Manual override: Plastic (Reinforced Nylon) Main Valve: Plastic (Reinforced Nylon & POM) Solenoid Operator: Stainless Steel AISI 300 & 400 series Seals: EPDM
Mounting	With bracket
Modular connection type	Thread type connection
Modular connection assembly recommendation	<ul style="list-style-type: none"> Manually tighten one station to another Using tools and/or excessive torques may lead to irreversible damage
Manual override	Latch: 3 position latch: Auto, Close, Open AC: 2 position: Auto, Open
Media	Air, water
Coil voltage	Latch, AC (according to table)
Standard protection class	IP66

* Can **only** be operated with supplied coil



PORT	NO	NC
1	Exhaust	Pressure
3	Pressure	Exhaust
COM	Out	Out

Voltage & Current

AC & DC

Solenoid	Inrush [A]	Holding [A]
24VAC-50 Hz	0.33	0.21

Latch Coil Resistance vs Input Voltage

Recommendations chart

Resistance [Ω]	Input voltage range [V]
4	6 - 9
9	12 - 14
12	14 - 16
23	18 - 21

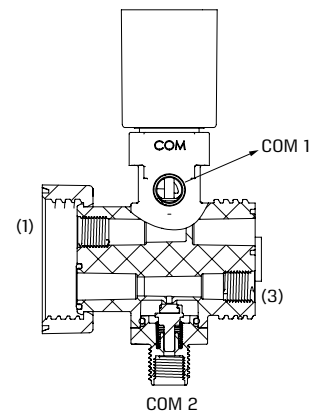

GEM-FLOW™ | G75-VM | Modular Manifold

Dimensions

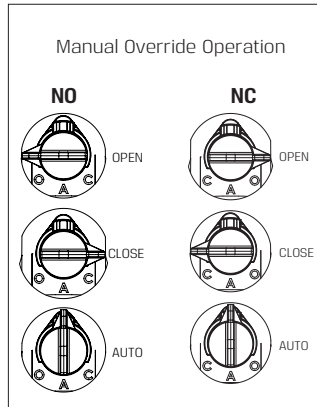
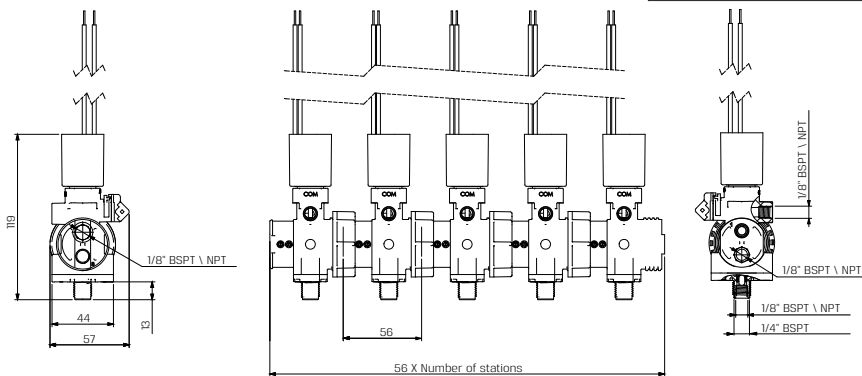

Mounting Bracket

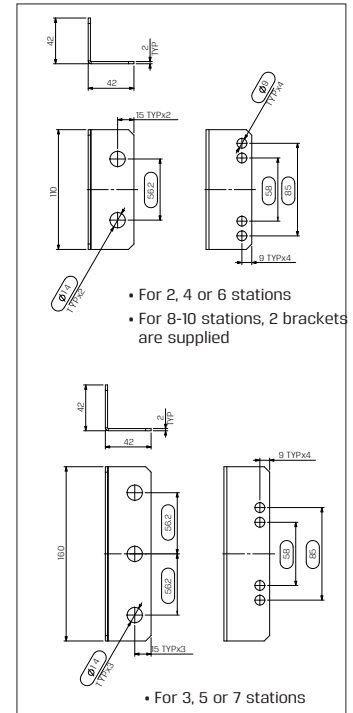

How to Order | Manifold

G75-VM	No. OF STATIONS ⁽¹⁾	BODY	PORT	FUNCTION	MANUAL OVERRIDE	ORIFICE	SEALS	TYPE	MOUNTING BRACKET	OUTLET ⁽⁴⁾	WIRES
	Specify quantity: 2 - 10	Plastic 4	1/8" BSPT 10 1/8" NPT 11	3W NC 3 3W NO 4	Plastic 1	1.8 3a	EPDM E	24VAC-50Hz ⁽²⁾ 4Ω ⁽³⁾ 9Ω ⁽³⁾ 12Ω ⁽³⁾ 23Ω ⁽³⁾	S1 SB SC SD S6	with 1 COM 1 1 COM 2 2	two three ⁽⁵⁾ a

Example: G75-VM-3410313aE-SB11

GEM-FLOW™ G75-VM manifold, 3 stations, plastic, 1/8" BSPT, 3W NC, plastic manual override, 1.8 orifice, EPDM seals, 4Ω latch, with mounting bracket, COM 1 outlet, two wires

- (1) Manifold designed for a maximum of 10 stations, the use of more will reduce the outlet flow rate to all
- (2) Refer to Voltage & Current AC & DC
- (3) Refer to Latch Coil Resistance vs Input Voltage | Recommendations chart
- (4) A plug will be fitted on the other outlet port
- (5) Latch only

How to Order | Manifold Components

G75-VM	TYPE	BODY	PORT	FUNCTION	MANUAL OVERRIDE	ORIFICE	SEALS	TYPE	OUTLET ⁽³⁾	WIRES	
	Left L	Plastic 4	1/8" BSPT 10 1/8" NPT 11	3W NC 3 3W NO 4	Plastic 1	1.8 3a	EPDM E	24VAC-50Hz ⁽¹⁾ 4Ω ⁽²⁾ 9Ω ⁽²⁾ 12Ω ⁽²⁾ 23Ω ⁽²⁾	S1 SB SC SD S6	COM 1 1 COM 2 2	two three ⁽⁴⁾ a

Example: G75-VM-L410313aE-SB1

GEM-FLOW™ G75-VM Left component, plastic, 1/8" BSPT, 3W NC, plastic manual override 1.8 orifice, EPDM seals, 4Ω latch, COM 1 outlet, two wires

- (1) Refer to Voltage & Current AC & DC
- (2) Refer to Latch Coil Resistance vs Input Voltage | Recommendations chart
- (3) A plug will be fitted on the other outlet port
- (4) Latch only

* To order manifolds manufactured according to your specific requirements, please contact our technical sales department

b **BACCARA**[®]
AUTOMATION & CONTROL



ISOLATED / FERTILIZER

SOLENOIDS

GEM-SOL® CPR (GEM-CPR)	Precise Isolated Proportional 2 Way NC	30
GEM-SOL® C32 (GEM-C)	Chem-Sol 1/4" 2 Way NC, NO	32
GEM-SOL® C32 (GEM-C)	Chem-Sol 1/2" 2 Way NC.....	34



ISOLATED/FERTILIZER SOLENOIDS

GEM-SOL® | CPR (GEM-CPR)

Precise Isolated Proportional 2 Way NC



Technical Data

Function	2 Way NC (with back-up battery)
Ports size	1/2" BSP & NPT
Orifice size	8mm (Up to 600 l/hour)
Pressure range	<ul style="list-style-type: none"> • Vacuum applications: (-1) - 0 Bar • Pressure applications: 0 - (+1) Bar *For other pressures, please consult our technical sales department
Temperature range	Fluid: -10° to 45°C (no freezing) Ambient: -10°C to 45°C
Materials	In contact with media: Valve body: <ul style="list-style-type: none"> • Standard: PVC (UV Protection) • Optional: According to customer demand or application (e.g Stainless steel) Diaphragm & seals: FKM, EPDM Not in contact with media: Operator housing: PP (UV protection) Manual override: Acetal (Manual override is standard)
Media	<ul style="list-style-type: none"> • Liquids & Gases *Please consult our technical sales department for a specific media <ul style="list-style-type: none"> • Application examples: <ul style="list-style-type: none"> - Irrigation fertilizing systems - Medical devices
Control signal	0-5V or 4-20mA
Valve stroke resolution	< 0.01mm
Valve stroke accuracy	< ± 0.01 mm
Full stroke duration	0.6 sec, each direction
Current consumption	<ul style="list-style-type: none"> • Standby Mode (Holding position): 25 [mA] • Active Control Mode: Up to 120 [mA] • Full Open/Close Mode (starting current): Up to 600 [mA]
Supply voltage	12-24 [V] ±5% AC (50 or 60Hz) Or 12-24[V] ±10% DC *For other supply voltages, please consult our technical sales department *Current and voltage spikes protections might be required. Please consult our technical sales department
Connection	5 wires cable (3m length): <ul style="list-style-type: none"> • Black & red: Supply voltage (polarity is not restricted) • Green: 0-5 V analog control signal • Blue: 4-20 mA analog control signal • Yellow: Analog control signal common
Recommended control signal resolution	Voltage: 20 mV Current: 0.064 mA
Standard / Certification	CE <ul style="list-style-type: none"> • EMC: EN55011 Group 1 - Class A EN61000-6-1 CFR 47 FCC Class A • SAFETY: IEC/EN61010-1
Standard protection class	IP67



Typical Performance Graph

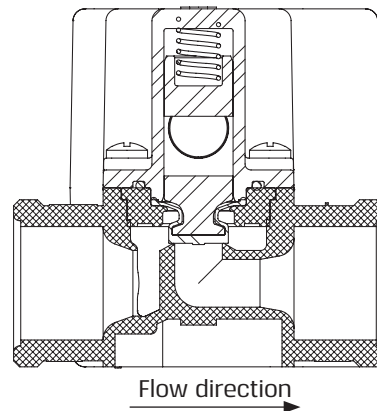
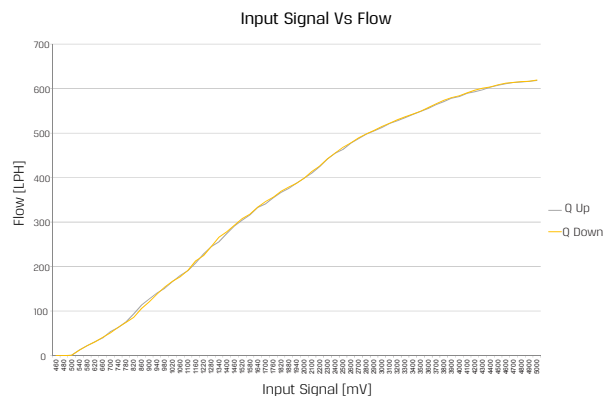

GEM-SOL® | CPR (GEM-CPR) | Precise Isolated Proportional 2 Way NC

Dimensions

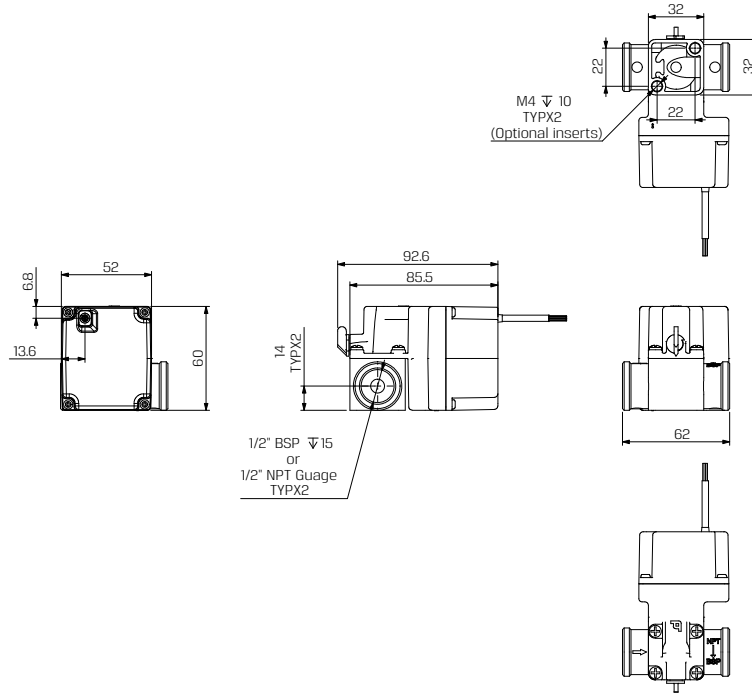

How to Order

GEM-CPR	PORT	FUNCTION	PRESSURE	SEALS	MANUAL OVERRIDE	CONTROL SIGNAL	VOLTAGE
1/2" BSP	40	2W NC 1	Vacuum 1	FKM V	Plastic 1	0-5 V 1	12-24 VDC 1
1/2" NPT	41		Pressure ⁽¹⁾ 2	EPDM E		4-20 mA 2	12-24 VAC 2

Example: GEM-CPR-4011E1-11

GEM-SOL® CPR (GEM-CPR), Precise Isolated proportional valve, 1/2" BSP, 2W NC, Vacuum, EPDM seals, plastic manual override with 0-5V control signal, 12-24VDC

(1) Maximum inlet pressure: 1 bar

* Please specify the working pressure range when placing an order

* To order valves manufactured according to your specific requirements, please contact our technical sales department

ISOLATED/FERTILIZER SOLENOIDS

GEM-SOL® | C32 (GEM-C)

Chem-Sol 1/4" 2 Way NC, NO

Technical Data

Function	2 Way NC, NO
Ports size	1/4" BSP & NPT
Orifice size	4.5mm * Option for 2.8 mm orifice. Please contact our technical sales department
Pressure range	See table
Kv (l/min)	5 l/min
Temperature range	Fluid: 5° to 50°C (no freezing) Ambient: -10°C to 50°C
Materials in contact with media	Manual override: NC: Plastic (Reinforced Nylon) NO: Manual override is not available Main Valve: Reinforced PPA Seals: FKM, EPDM, Silicone, Viton™ Extreme™ ETP-600S
Applications	<ul style="list-style-type: none"> • Chemical process • Water treatment • Analysis device etc
Coil voltage	<ul style="list-style-type: none"> • Voltage and power consumption - see table • All Baccara coil voltages are ± 10% of nominal
Standard protection class	IP65 with connector * Option: IP68 (please refer to GEM-BP coil)



Pressure (bar) NC

Coil Current/Power	Flow direction not restricted	Flow direction restricted
ADC *	0 to 2.5 bar	0 to 0.6 bar
AC 8W	0 to 2.5 bar	0 to 0.7 bar
AC 5.5W	0 to 2 bar	0 to 0.5 bar
DC 5.5W	0 to 1.5 bar	0 to 0.4 bar

Vacuum (bar) NC

Coil Current/Power	Flow direction not restricted	minimum Δp
ADC *	-1 to 0 bar	1 bar
AC 5.5W	-1 to 0 bar	
DC 5.5W	-1 to 0 bar	

Pressure (bar) NO

Coil Current/Power	Flow direction not restricted	Flow direction restricted ⁽¹⁾
ADC*, AC 8W or DC10W	0 to 1 bar	0 to 0.5 bar
5.5W AC/DC	0 to 1 bar	0 to 0.5 bar

(1) Higher input pressure of up to 1atm can be achieved with minimal pressure drop on the valve of 0.3atm

* ADC valves are only suitable for use with AC8W or DC10W coils.

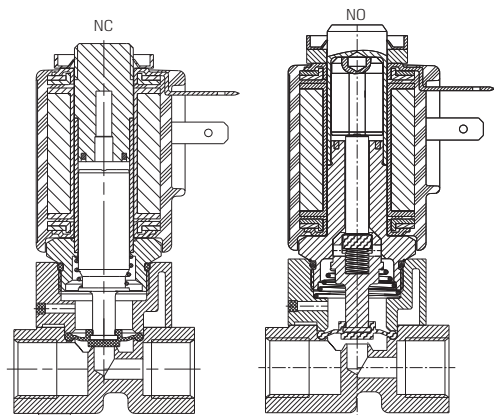

← Flow direction Pressure
→ Flow direction Vacuum

Voltage & Power Consumption

V	AC (W)						DC (W)		
	50 Hz			60 Hz			10	5.5	3.5
6							•	•	
12	•			•			•	•	
24	•	•		•	•		•	•	
48	•			•			•		
110	•			•	•		•		
120	•			•	•				
220	•	•		•			•		
230	•	•		•	•				
240	•			•			•		

• Available options

GEM-SOL® | C32 (GEM-C) | Chem-Sol 1/4" 2 Way NC, NO

Dimensions

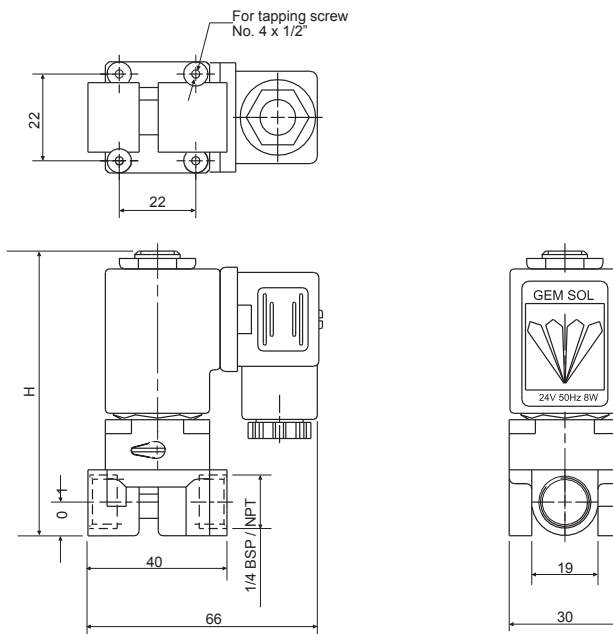

Notes

Type	Valve Description	H
NC	GEM-C-12 □1...	81
NO	GEM-C-12 □2...	84.5

How to Order

GEM-C	BODY	PORT	FUNCTION	PRESSURE	SEALS	MANUAL OVERRIDE ⁽¹⁾	VOLTAGE	POWER	CONNECTOR
	Plastic 1	1/4" BSP 20	2W NC 1	Vacuum 1	FKM	V None 0	without coil 0	No coil 0	with 1
		1/4" NPT 21	2W NO 2	Pressure 2	EPDM	E Plastic * 1	6 ⁽²⁾ 1	AC8W 50Hz 1	with LED 2
			2W NO* 2a		Silicone * S		12 2	AC8W 60Hz 2	flying leads coil* 4
					Viton™ Extreme™ ETP-600S * X		24 3	DC10W 3	with 1/2" Hub 5
							48 4	AC5.5W 50Hz 4	surge protection with LED* 6
							110 5	AC5.5W 60Hz 5	connector with moulded cable 7
							120 6	DC5.5W 7	other 9
							220 7A		
							230 7		
							240 8		
							Latch/ other *⁽³⁾ 9		

* **SPECIAL OPTIONS** | Extended lead times, Non-stock items, MOQ may be applicable

Example: GEM-C-12012V1-321

GEM-SOL® C32 (GEM-C) Chem-Sol, Plastic, 1/4" BSP, 2W NC, Pressure, FKM, plastic manual override, 24V AC 8W 60Hz with connector

(1) NO - manual override is not available

(2) DC only

(3) For specifying Latch type coil, please refer to A3P32 (GEM-A3P) valve - How to Order table

* Note: When ordering without coil, please define what current and pressure rating is needed (DC, AC or ADC), otherwise an ADC valve will be supplied

* To order valves manufactured according to your specific requirements, please contact our technical sales department

ISOLATED/FERTILIZER SOLENOIDS

GEM-SOL® | C32 (GEM-C)

Chem-Sol 1/2" 2 Way NC

Technical Data

Function	2 Way NC
Ports size	1/2" BSP & NPT
Orifice size	8mm (Up to 600 l/hour)
Pressure range	See table
Kv (l/min)	18 l/min
Temperature range	Fluid: 5°C to 50°C (no freezing) Ambient: -10°C to 50°C
Materials in contact with media	Manual override: Plastic (Reinforced Nylon) * Available for vacuum application only Main Valve: PVC Seals: FKM, EPDM
Applications	<ul style="list-style-type: none"> • Chemical process • Water treatment • Analysis device etc
Coil voltage	<ul style="list-style-type: none"> • Voltage and power consumption - see table • All Baccara coil voltages are from -5% to ±10% of nominal
Standard protection class	IP65 with connector * Option: IP68 (please refer to GEM-BP coil)

- Supplied with mounting threads on request, please specify



Pressure (bar) NC

Coil Current/Power	Flow direction not restricted	Flow direction restricted
AC 8W, DC10W	0 to 0.7 bar	Min dp 0.3 bar

Vacuum (bar) NC

Coil Current/Power	Flow direction not restricted	Flow direction restricted
AC 8W	-1 to 0.5 bar	-1 to 0.5 bar
AC 5.5W	-0.5 to 0.5 bar	-0.8 to 0.5 bar
DC 10W	-0.4 to 0.5 bar	-0.6 to 0.5 bar

Voltage & Power Consumption

V	AC (W)						DC (W)		
	50 Hz			60 Hz			10	5.5	3.5
6							•	•	
12	•	•		•	•		•	•	
24	•	•	•	•	•	•	•	•	
48	•	•		•	•		•	•	
110	•	•		•	•	•	•	•	
120	•	•		•	•	•			
220	•	•	•	•	•	•	•	•	
230	•	•	•	•	•	•			
240	•	•		•	•		•	•	

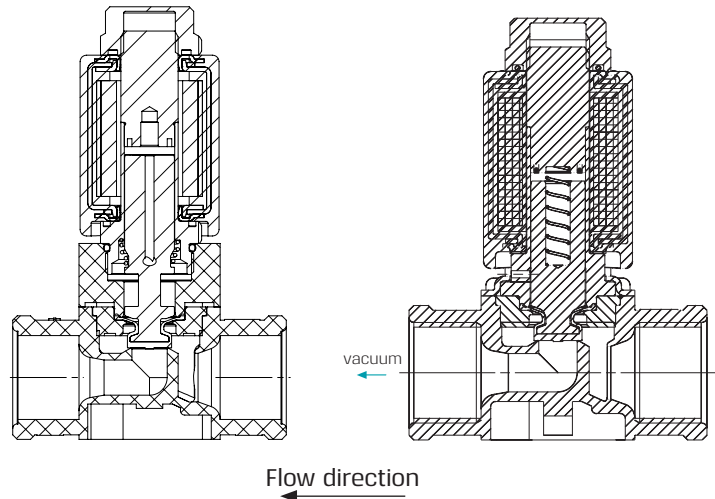

Available options:

- Vacuum
- Pressure

GEM-SOL® | C32 (GEM-C) | Chem-Sol 1/2" 2 Way NC

Dimensions

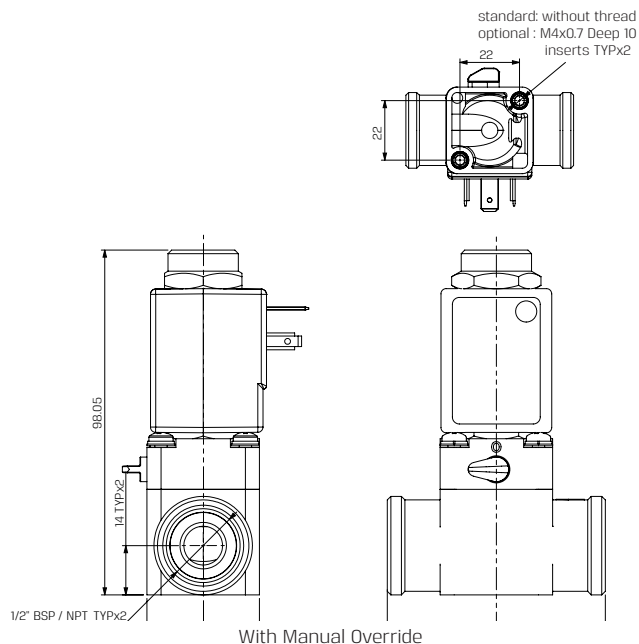
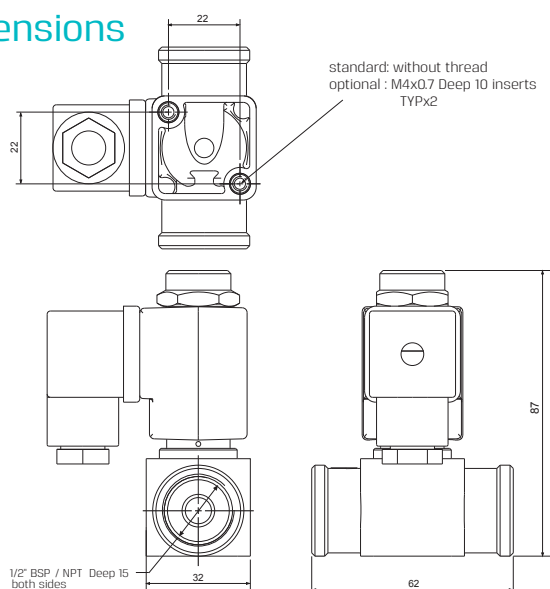

How to Order

GEM-C	PORT	FUNCTION	PRESSURE	SEALS	MANUAL OVER-RIDE	* When ordering without coil, please define what current and pressure rating is needed (DC, AC)										
						VOLTAGE	POWER	CONNECTOR								
	1/2" BSP	40	2W NC	1	Vacuum	1	FKM	V	None	Null	W/out coil	0	No coil	0	with	1
	1/2" NPT	41			Pressure	2	EPDM	E	Plastic ⁽¹⁾	1	6 ⁽²⁾	1	AC8W 50Hz	1	with LED	2
											12	2	AC8W 60Hz	2	flying leads coil*	4
											24	3	DC10W	3	with 1/2" Hub	5
											48	4	AC5.5W 50Hz	4	surge protection with LED*	6
											110	5	AC5.5W 60Hz	5	connector with moulded cable	7
											120	6			other	9
											220	7A				
											230	7				
											240	8				
											Latch/ other* ⁽³⁾	9				

* SPECIAL OPTIONS | Extended lead times, Non-stock items, MOQ may be applicable

Example: GEM-C-4011V1-321

GEM-SOL® C32 (GEM-C) Chem-Sol, 1/2"BSP, 2W NC for vacuum, FKM, plastic manual override, 24V AC 8W 60Hz with connector

(1) Available for Vacuum application only

(2) DC only

(3) For specifying Latch type coil, please refer to A3P32 (GEM-A3P) valve - How to Order table

* To order valves manufactured according to your specific requirements, please contact our technical sales department

b **BACCARA**[®]
AUTOMATION & CONTROL



ELECTRIC & HYDRAULIC

VALVES

GEM-SOL® S32 (GEM-S)	1/4" - 1" 2 Way NC, NO	38
GEM-SOL® S32 (GEM-S)	1/4" - 1" 2 Way NC, NO	40
GEM-SOL® S32 (GEM-S)	Pilot Operated 3/4" - 2" 2 Way NC, NO	42
GEM-SOL® S32 (GEM-S-4)	Upstream Pilot Control Integrated with GEM-SOL® Operator 3/4" - 2" 2 Way NC	44
GEM-FLOW™ G75-S	Pilot Operated 1/2" 2 Way NC	46
GEM-FLOW™ G75-S	Electric 3/4" - 2" 2 Way NC	48
GEM-SOL® Z32 (GEM-Z)	Zero Differential Pressure 1/4" - 3/4" 2 Way NC, NO	50
GEM-FLOW™ G75-S	Hydraulic 3/4"- 2" 2 Way	52
GEM-FLOW™ G75-S	3 Way Integral Solenoid Pilot Control 3/4" - 2" NC	54
GEM-FLOW™ G75-SE	3 Way External Solenoid Pilot Control 3/4" - 2" NC, NO	55
GEM-FLOW™ G75	3 Way Manual Selector 3/4" - 2" NC, NO	56
GEM-FLOW™ G75	Pressure Reducing 3/4" - 2" 2 Way NC	57



ELECTRIC & HYDRAULIC VALVES

GEM-SOL® | S32 (GEM-S)

1/4" - 1" 2 Way NC, NO



Brass | 1/4" | NC



Stainless Steel | 3/4" | NC

Technical Data

Function	2 Way NC, NO
Ports size	1/4", 3/8", 1/2", 3/4", 1" BSP & NPT
Pressure range	See table * Minimum pressure differential of 0.3 or 0.5 is required
Kv (l/min)	See table
Temperature range	Fluid: -10°C to 80°C (no freezing) Ambient: -10°C to 50°C
Materials in contact with media	Manual override: NC - Brass screw NOa* - Manual override unavailable * pressure is supplied through base Main Valve: Brass, Stainless Steel AISI 316 Solenoid Operator: Stainless Steel AISI 300 & 400 series Seals: NBR, FKM, EPDM
Coil voltage	• Voltage and power consumption - see table • All Baccara coil voltages are ± 10% of nominal
Standard protection class	IP65 with connector * Option: IP68 (please refer to GEM-BP Coil)

- Slow closing system to prevent water hammer effect

Voltage & Power Consumption

V	AC (W)						DC (W)		
	50 Hz			60 Hz			10	5.5	3.5
6							•		
12	•			•			•		
24	•	•*		•			•		
48	•			•			•		
110	•			•			•		
120	•			•	•*				
220	•	•*		•			•		
230	•			•	•*				
240	•			•			•		

- Available options

* Only for NC

GEM-SOL® | S32 (GEM-S) | 1/4" - 1" 2 Way NC, NO

Dimensions

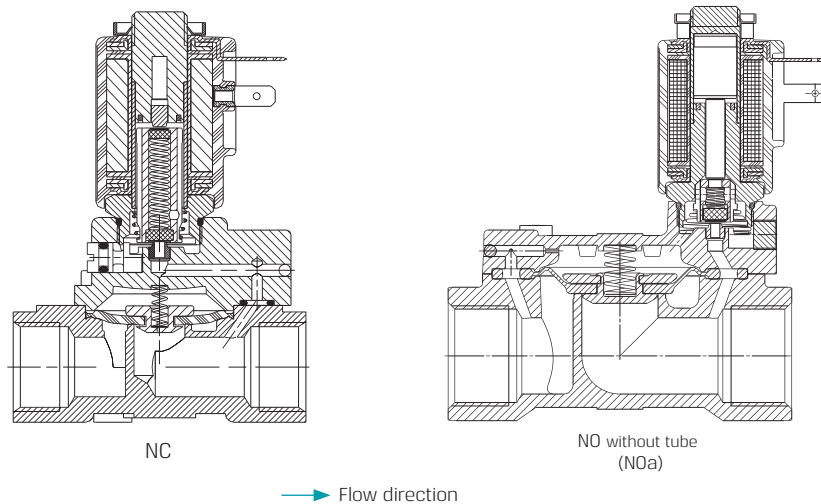

Pressure (bar) & Flow NO/NC GEM-S-□-20...41

Size	Orifice (mm)	Pressure (bar)		Kv (l/min)
		AC, DC	ADC	
1/4"	8	0.5 to 20	0.5 to 15	12
3/8"	8			16
1/2"	12			35

Pressure (bar) & Flow NO/NC GEM-S-□-□r

Size	Orifice (mm)	Pressure (bar)		Kv (l/min)
		AC, DC	ADC	
1/2"	16	0.5 to 20	0.5 to 15	60

Pressure (bar) & Flow NO/NC GEM-S-□-50...60

Size	Orifice (mm)	Pressure range (bar) AC, DC & ADC	Kv (l/min)
3/4"	20	0.3 to 15	130
1"	25	0.5 to 15	200

ELECTRIC & HYDRAULIC VALVES

GEM-SOL® | S32 (GEM-S)

1/4" - 1" 2 Way NC, NO

Dimensions

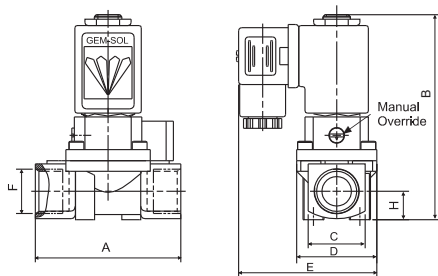
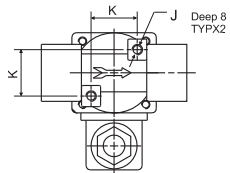

NC

Size	A	B	C	D	E	F	H	J	K	Weight with coil
1/4"-3/8"	58	89	22	32	62	1/4"-3/8" BSP/NPT	11	M5x0.8	22	466gr
1/2"	70	95	27	38	70	1/2" BSP/NPT	13.5	M5x0.8	22	562gr

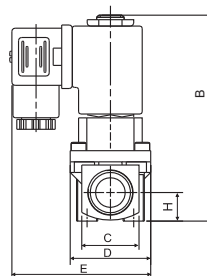

NOa

Size	A	B	C	D	E	H	L	I	J
3/4" BSP/NPT	90	106	32	55	32	17	15	25	103
1" BSP/NPT	100	112.5	38.5	65	34	21	16	29.5	109.50

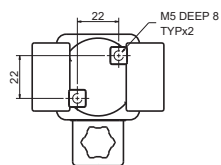
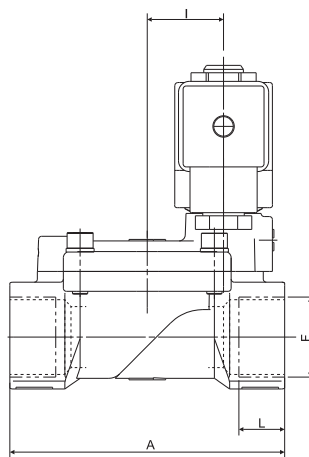
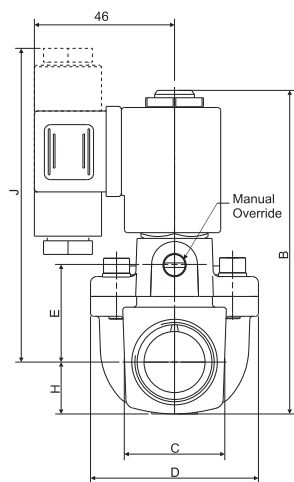

GEM-S-4□r (16 mm orifice)

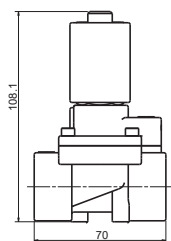

NC

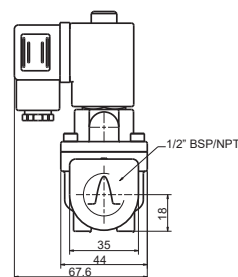
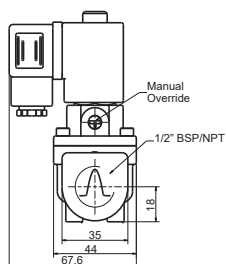

NOa

GEM-SOL® | S32 (GEM-S) | 1/4" - 1" 2 Way NC, NO

How to Order

GEM-S	BODY	PORT	FUNCTION	SEALS	MANUAL OVERRIDE	VOLTAGE	POWER	CONNECTOR								
-	Brass	2	1/4" BSP	20	2W NC	1	NBR	N	None * 0	without coil	0	No coil	0	with	1	
	Stainless Steel	3	1/4" NPT	21	2W NO ⁽¹⁾ through base	2a	FKM * ⁽²⁾	V	Slot	2	6 ⁽³⁾	1	AC8W 50Hz	1	with LED	2
			3/8" BSP	30							12	2	AC8W 60Hz	2	with 1/2" Hub	5
			3/8" NPT	31							24	3	DC10W	3	with 1/2" Hub	5
			1/2" BSP	40							48	4	AC5.5W 50 Hz ⁽⁵⁾	4	surge protection with LED*	6
			1/2" NPT	41							110	5	AC5.5W 60 Hz ⁽⁵⁾	5	connector with moulded cable	7
			3/4" BSP	50							120	6			other	9
			3/4" NPT	51							220	7A				
			1" BSP	60							230	7				
			1" NPT	61							240	8				

* SPECIAL OPTIONS | Extended lead times, Non-stock items, MOQ may be applicable

Example: GEM-S-2201N2-321

GEM-SOL® S32 (GEM-S) pilot operated, Brass, 1/4"BSP, 2W NC, NBR seals, slot manual override, 24V AC8W 60Hz with connector

(1) Manual Override unavailable

(2) For 3/4" and 1"

(3) DC only

(4) For specifying Latch type coil, please refer to A3P32 (GEM-A3P) valve - How to order table

(5) Only for NC

* Note: When ordering without coil, please define what current and pressure rating is needed (DC, AC or ADC), otherwise an ADC valve will be supplied

How to Order

GEM-S	BODY	PORT	FUNCTION	SEALS	MANUAL OVERRIDE	VOLTAGE	POWER	CONNECTOR							
-	Brass	2	1/2" BSP *	40r	2W NC	1	NBR	N	None * 0	without coil	0	No coil	0	with	1
			1/2" NPT *	41r	2W NO ⁽¹⁾ through base	2a	FKM	V	Slot	2	6 ⁽²⁾	1	AC8W 50Hz	1	with LED
			12	2							AC8W 60Hz	2	with 1/2" Hub	5	
			24	3							DC10W	3	with 1/2" Hub	5	
			48	4							AC5.5W 50 Hz ⁽⁴⁾	4	surge protection with LED*	6	
			110	5							AC5.5W 60 Hz ⁽⁴⁾	5	connector with moulded cable	7	
			120	6									other	9	
			220	7A											
			230	7											
			240	8											
															Latch/other * ⁽³⁾ 9

* SPECIAL OPTIONS | Extended lead times, Non-stock items, MOQ may be applicable

Example: GEM-S-240r1N2-321 (16mm orifice size)

GEM-SOL® S32 (GEM-S) pilot operated, brass, 1/2"BSP, 2W NC, NBR seals, slot manual override, 24V AC8W 60Hz with connector

(1) Manual Override unavailable

(2) DC only

(3) For specifying Latch type coil, please refer to A3P32 (GEM-A3P) valve - How to Order table

(4) Only for NC

* Note: When ordering without coil, please define what current and pressure rating is needed (DC, AC or ADC), otherwise an ADC valve will be supplied

* To order valves manufactured according to your specific requirements, please contact our technical sales department

ELECTRIC & HYDRAULIC VALVES

GEM-SOL® | S32 (GEM-S)

Pilot Operated 3/4" - 2" 2 Way NC, NO

Technical Data

Function	2 Way NC, NO
Ports size	3/4", 1", 1-1/2", 2" BSPT & NPT
Connection	Female BSPT or NPT thread
Pressure range	0.3 to 10 bar
Temperature range	Fluid: 5°C to 50°C (no freezing) Ambient: -10°C to 50°C
Solenoid	GEM-SOL® 3/4" UNEF, 2 Way NC or NO solenoids. All voltages
Materials in contact with media	Manual override: Plastic (Reinforced Nylon) Body & cover: Plastic (Reinforced Nylon) Spring: Stainless Steel AISI 302 Diaphragm: NR : 3/4", 1" EPDM : 1-1/2", 2" Seals: NBR Screws: Stainless Steel AISI 304 Solenoid: Stainless Steel AISI 300 & 400 series
Coil voltage	• Voltage and power consumption - see table • All Baccara coil voltages are ± 10% of nominal
Standard protection class	IP65 with connector * Option: IP68 (please refer to GEM-BP Coil)

- Progressive opening and shut off that prevents water hammer



Head Loss for Fully Open Valve

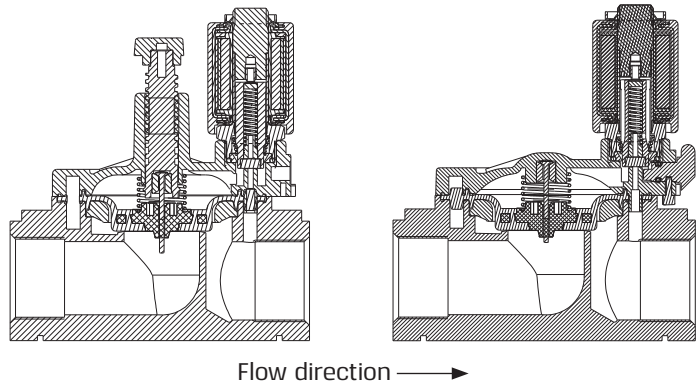
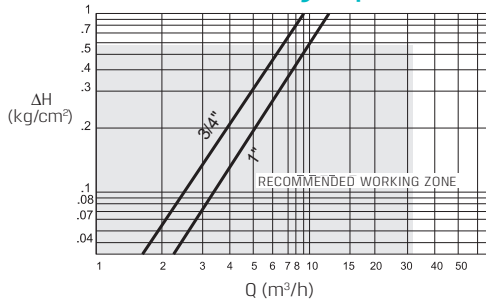

Head Loss for Fully Open Valve

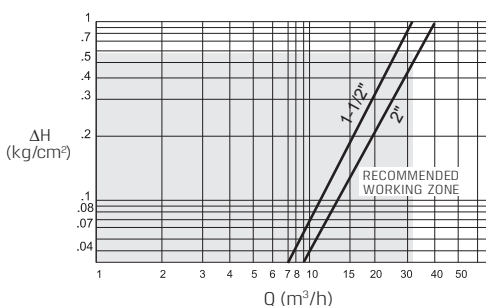

Flow Factor & Orifice

Size	Orifice (mm)	Kv (l/min)
3/4"	27	140
1"	27	200
1-1/2"	55	520
2"	55	600

GEM-SOL® | S32 (GEM-S) | Pilot Operated 3/4" - 2" 2 Way NC, NO

Dimensions

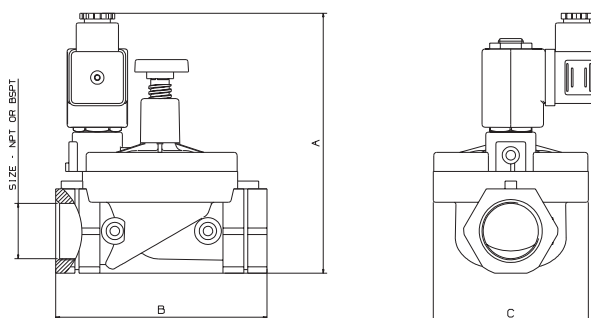

with flow control

Size	A	B	C
3/4"	108	110	81
1"	135.5	110	81
1-1/2"	180	160	126
2"	190	170	126

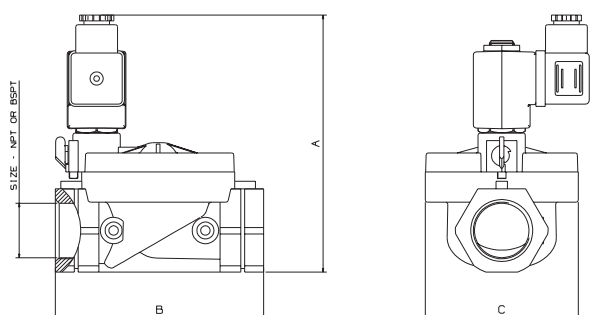

without flow control

Size	A	B	C
3/4"	128.5	110	81
1"	135.5	110	81
1-1/2"	168	160	126
2"	179.5	170	126

How to Order

* When ordering without coil, please define what current and pressure rating is needed (DC, AC)

GEM-S	BODY	PORT	FUNCTION	SEALS	MANUAL OVERRIDE	FLOW CONTROL	VOLTAGE	POWER	CONNECTOR									
Plastic	4	3/4" BSPT	50	2W NC	1	NR	N	None	0	with	1	without coil	0	No coil	0	with	1	
		3/4" NPT	51	2WNO	2a			Plastic	1	without ⁽¹⁾	2	6 ⁽²⁾	1	AC8W 50Hz	1	with LED	2	
		1" BSPT	60									12	2	AC8W 60Hz	2	flying leads coil *	4	
		1" NPT	61									24	3	DC10W	3	with 1/2" Hub	5	
		1-1/2" BSPT	70									48	4	AC5.5W 50Hz	4	surge protection with LED *	6	
		1-1/2" NPT	71									110	5	AC5.5W 60Hz	5	connector with moulded cable	7	
		2" BSPT	80									120	6			other	9	
		2" NPT	81									220	7A					
											230	7						
											240	8						
																	Latch/other* ⁽³⁾	9

* SPECIAL OPTIONS | Extended lead times, Non-stock items, MOQ may be applicable

Example: GEM-S-4501N11-331

GEM-SOL® S32 (GEM-S) pilot operated, Plastic, 3/4" BSPT, 2W NC, NR, plastic manual override, with flow control, 24V DC 10W with connector

(1) 3/4", 1" valves only

(2) DC only

(3) For specifying Latch type coil, please refer to A3P32 (GEM-A3P) valve - How to Order table

* To order valves manufactured according to your specific requirements, please contact our technical sales department

GEM-SOL® | S32 (GEM-S-4)

Upstream Pilot Control Integrated with GEM-SOL® Operator 3/4" - 2" 2 Way NC

Technical Data

Function	2 Way NC
Ports size	3/4", 1", 1-1/2", 2" BSPT & NPT
Connection	Female BSPT or NPT thread
Pressure range	0.3 to 10 bar
Temperature range	Fluid: 5°C to 50°C (no freezing) Ambient: -10°C to 50°C
Solenoid	GEM-SOL® (GEM-OG)
Materials in contact with media	Manual override: Plastic (Reinforced Nylon) Body & cover: Plastic (Reinforced Nylon) Spring: Stainless Steel AISI 302 Diaphragm: NR : 3/4", 1" EPDM : 1-1/2", 2" Seals: NBR Screws: Stainless Steel AISI 304 Solenoid: Stainless Steel AISI 300 & 400 series
Coil voltage	• Voltage and power consumption - see table • All Baccara coil voltages are ± 10% of nominal
Standard protection class	IP65 with connector * Option: IP68 (please refer to GEM-BP Coil)

- Progressive opening and shut off that prevents water hammer



Head Loss for Fully Open Valve

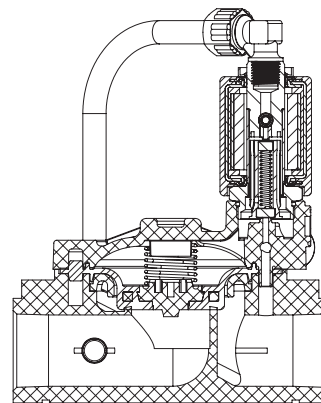
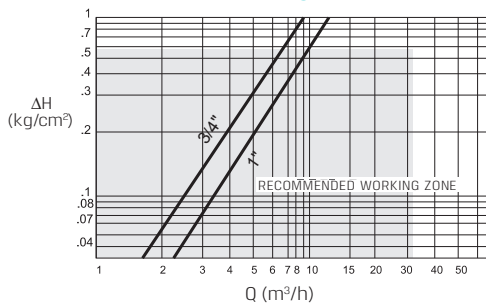

Flow direction →

Head Loss for Fully Open Valve

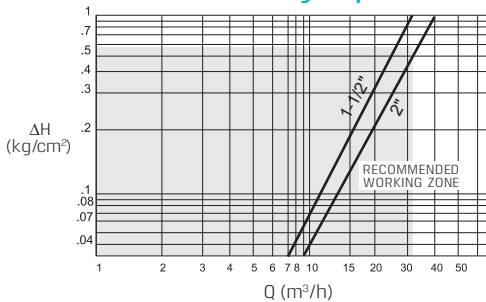

Flow Factor & Orifice

Size	Orifice (mm)	Kv (l/min)
3/4"	27	140
1"	27	200
1-1/2"	55	520
2"	55	600

GEM-SOL® | S32 (GEM-S-4) | Upstream Pilot Control Integrated with GEM-SOL® Operator 3/4" - 2" 2 Way NC

Dimensions

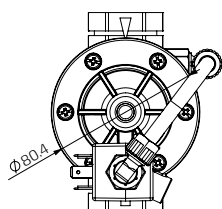
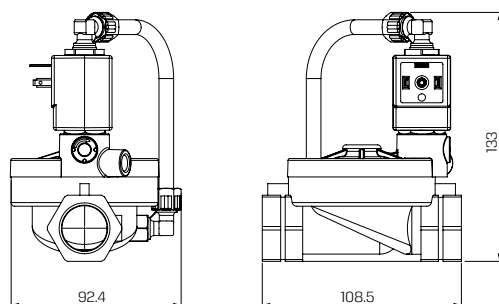

How to Order

* When ordering without coil, please define what current and pressure rating is needed (DC, AC)

GEM-S-4	-	BODY	PORT	FUNCTION	SEALS	MANUAL OVERRIDE	FLOW CONTROL	-										
								VOLTAGE	POWER	CONNECTOR								
Plastic	4	3/4" BSPT	50	External pilot	4	NR	N	None	0	with	1	without coil	0	No coil	0	with	1	
			51	Upstream pilot	4H		Plastic	1	without ⁽¹⁾	2	6 ⁽²⁾	1	AC8W 50Hz	1	with LED	2		
			60								12	2	AC8W 60Hz	2	flying leads coil *	4		
			61								24	3	DC10W	3	with 1/2" Hub	5		
			70								48	4	AC5.5W 50Hz	4	surge protection with LED *	6		
			71								110	5	AC5.5W 60Hz	5	connector with moulded cable	7		
			80								120	6			other	9		
			81								220	7A						
									230	7								
									240	8								
																	Latch/ other * ⁽³⁾	9

* **SPECIAL OPTIONS** | Extended lead times, Non-stock items, MOQ may be applicable

Example: GEM-S-4-4504N11-331

GEM-SOL® S32 (GEM-S-4) pilot operated upstream, Plastic, 3/4" BSPT, External pilot, NR seals, plastic manual override, with flow control, 24V DC 10W with connector

(1) 3/4", 1" valves only

(2) DC only

(3) For specifying Latch type coil, please refer to A3P32 (GEM-A3P) valve - How to Order table

* To order valves manufactured according to your specific requirements, please contact our technical sales department

ELECTRIC & HYDRAULIC VALVES

GEM-FLOW™ | G75-S

Pilot Operated 1/2" 2 Way NC

Technical Data

Function	2 Way NC
Ports size	1/2" BSP & NPT
Orifice size	12mm
Pressure range	0.5 to 12 bar * Minimum pressure differential of 0.5 is required
Kv (l/min)	35 l/min
Temperature range	Fluid: 5°C to 50°C (no freezing) Ambient: -10°C to 50°C
Materials in contact with media	Main Valve: Plastic (Reinforced Nylon) Solenoid Operator: Stainless Steel AISI 300 & 400 series Seals: NBR, EPDM, FKM Spring: Stainless Steel AISI 300 series
Solenoid	G75 2W NC solenoids, all voltages.
Coil voltage	• Voltage and power consumption - see table • All Baccara coil voltages are ± 10% of nominal
Standard protection class	IP65



Voltage & Power Consumption

	AC (W)	DC (W)
	50 Hz	
V	2	4.5
12	•	•
24	•	•
110	• 2 Way only	

- Available options

Voltage & Current

AC & DC

Solenoid	Voltage	Inrush [A]	Holding [A]
2 Way 50 Hz	V +10% n-20%	0.3	0.19
2 Way 60 Hz		0.2	0.14
3 Way 50/60 Hz		0.125	0.125
DC		4.5W	

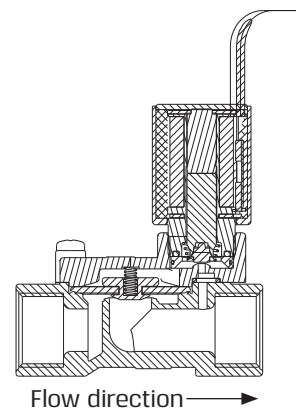

Latch Coil Resistance vs Input Voltage

Recommendations chart

Resistance [Ω]	Input voltage range [V]
4	6 - 9
9	12 - 14
12	14 - 16
23	18 - 21

GEM-FLOW™ | G75-S | Pilot Operated 1/2" 2 Way NC

Dimensions

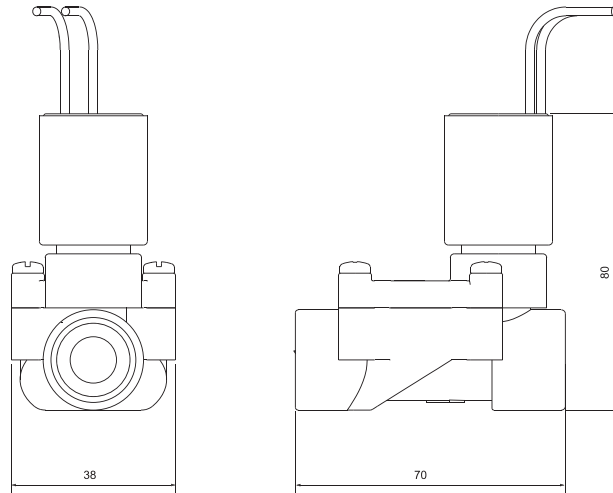

How to Order

G75-S	BODY	PORT	FUNCTION	SEALS	MANUAL OVERRIDE	VOLTAGE ⁽¹⁾	WIRES
-	Plastic 4	1/2" BSP 40	2W NC 1	NBR N	None 0	24V AC 1	two null
		1/2" NPT 41		FKM V		12V AC 3	three ⁽²⁾ a
				EPDM E		12V DC 4	
						24V DC 5	
						23Ω 6	
						110V AC 7	
						4Ω B	
						9Ω C	
						12Ω D	

Example: G75-S-4401N0-1

GEM-FLOW™ G75-S pilot operated, 1/2" BSP, 2W NC, NBR, no manual override, 24V AC, two wires

(1) For Latch: Refer to Latch Coil Resistance vs Input Voltage | Recommendations chart

(2) For Latch only

* To order valves manufactured according to your specific requirements, please contact our technical sales department

ELECTRIC & HYDRAULIC VALVES

GEM-FLOW™ | G75-S

Electric 3/4" - 2" 2 Way NC

Technical Data

Function	2 Way NC
Ports size	3/4", 1", 1-1/2", 2" BSPT & NPT
Pressure range	0.3 to 10bar
Temperature range	(Fluid: 5°C to 50°C (no freezing) Ambient: -10°C to 50°C)
Materials in contact with media	Manual override: Plastic (Reinforced Nylon) Main Valve: Plastic (Reinforced Nylon) Solenoid Operator: Stainless Steel AISI 300 & 400 series Diaphragm: NR : 3/4", 1" EPDM : 1-1/2", 2" Seals: NBR Spring: Stainless Steel AISI 300 series
Solenoid	<ul style="list-style-type: none"> G75, 2W NC solenoids, all voltages. AC, DC and Latch
Coil voltage	<ul style="list-style-type: none"> Voltage and power consumption - see table All Baccara coil voltages are ± 10% of nominal



G75-S | 1" | NC with plastic manual override



G75-S | 2" | NC Latch with handle manual override

Voltage & Current

AC & DC

Solenoid	Voltage	Inrush [A]	Holding [A]
2 Way 50 Hz	V +10% n-20%	0.3	0.19
2 Way 60 Hz		0.2	0.14
3 Way 50/60 Hz		0.125	0.125
DC		4.5W	

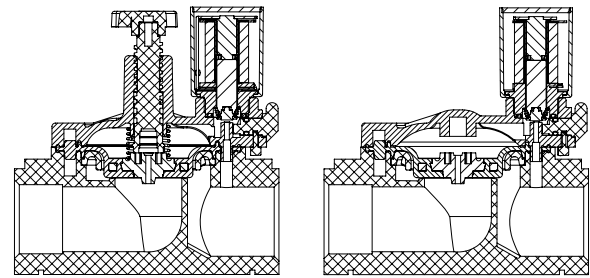

Flow direction →
with flow control without flow control

Voltage & Power Consumption

	AC (W)		DC (W)
	50 Hz		
V	2	4.5	
12	•	•	
24	•	•	
110	•	•	
	2 Way only		

- Available options

Head Loss for Fully Open Valve

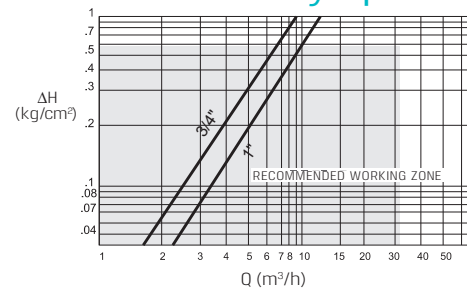

Head Loss for Fully Open Valve

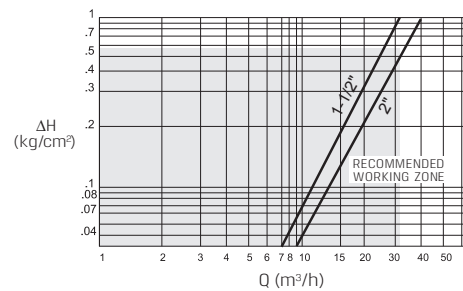

Latch Coil Resistance vs Input Voltage

Recommendations chart

Resistance [Ω]	Input voltage range [V]
4	6 - 9
9	12 - 14
12	14 - 16
23	18 - 21

GEM-FLOW™ | G75-S | Electric 3/4" - 2" 2 Way NC

Dimensions

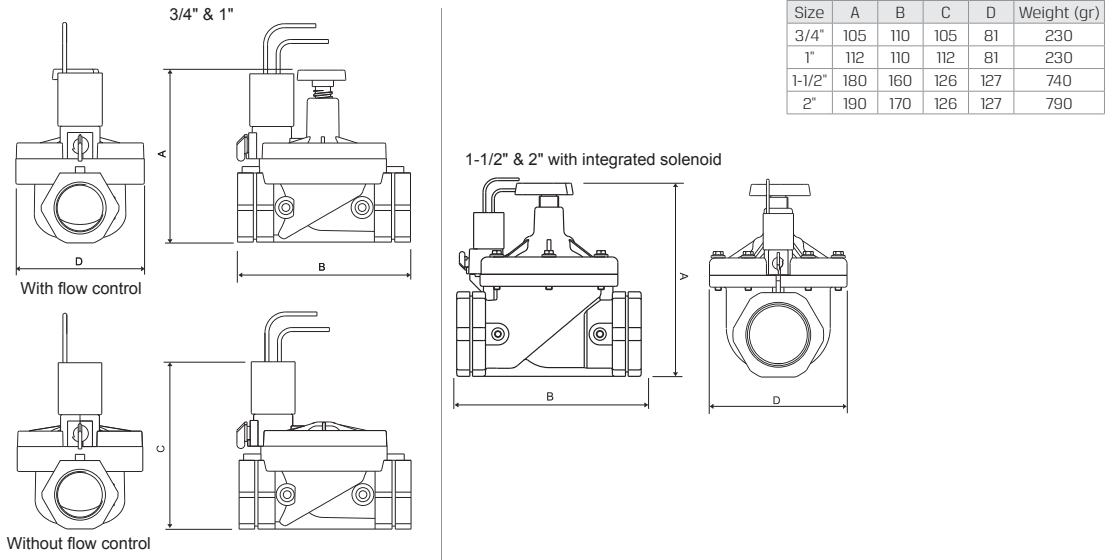

How to Order

G75-S	PORT	FUNCTION	MANUAL OVERRIDE	FLOW CONTROL	VOLTAGE ⁽³⁾	WIRES			
3/4" BSPT	50	2W NC	1	with	5	24V AC	1	two	null
3/4" NPT	51		Plastic	without ⁽²⁾	6	12V AC	3	three ⁽¹⁾	a
1" BSPT	60		Handle ⁽¹⁾			12V DC	4		
1" NPT	61					24V DC	5		
1-1/2" BSPT	70					23Ω	6		
1-1/2" NPT	71					110V AC	7		
2" BSPT	80					4Ω	B		
2" NPT	81					9Ω	C		
						12Ω	D		

Example: G75-S-501051

GEM-FLOW™ G75-S electric valve, 3/4" BSPT, 2W NC, no manual override, with flow control, 24V AC, two wires

(1) For Latch only

(2) 3/4", 1" valves only

(3) For Latch: Refer to Latch Coil Resistance vs Input Voltage | Recommendations chart

* To order valves manufactured according to your specific requirements, please contact our technical sales department

ELECTRIC & HYDRAULIC VALVES

GEM-SOL® | Z32 (GEM-Z)

Zero Differential Pressure 1/4" - 3/4" 2 Way NC, NO

Technical Data

Function	2 Way NC, NO
Ports size	1/4", 1/2", 3/4" BSP & NPT
Pressure range	See table * For plastic body, maximum working pressure is 4 bar
Kv (l/min)	See table
Temperature range	Fluid: -10°C to 80°C (no freezing) Ambient: -10°C to 50°C
Materials in contact with media	Main Valve: Brass, Stainless Steel AISI 316, Plastic (Reinforced Nylon)* * Plastic (Reinforced Nylon): only available in 1/2" Solenoid Operator: Stainless Steel AISI 300 & 400 series Seals: NBR, FKM, EPDM
Media	Air, water, oil
Coil voltage	• Voltage and power consumption - see table • All Baccara coil voltages are ± 10% of nominal
Standard protection class	IP65 with connector * Option: IP68 (please refer to GEM-BP Coil)

- When switching from an AC to a DC coil, the solenoid operator must be changed as well.
- Can be used in vacuum application from -1 bar to maximum pressure - see tables.

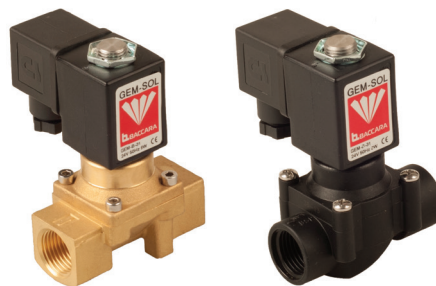

Brass | 1/2" | NC

Plastic | 1/2" | NC



Stainless Steel | 1/2" | NC

Pressure (bar) & Flow NC

Size	Orifice (mm)	Pressure (bar)		Kv (l/min)
		AC	DC	
1/4"	8	0 to 14	0 to 7	12
1/2"	12	0 to 14	0 to 8	18

Pressure (bar) & Flow NC (GEM-Z-□□r)

Size	Orifice (mm)	Pressure (bar)		Kv (l/min)
		AC	DC	
1/2"	16	0 to 10	0 to 6	60
3/4"	16	0 to 10	0 to 6	80

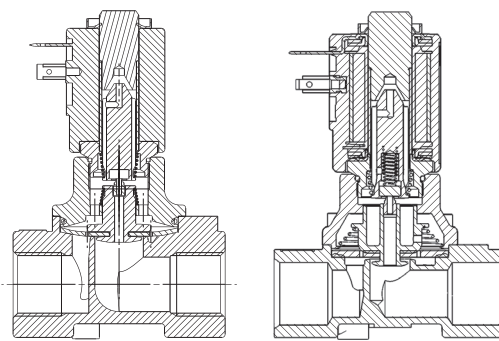

GEM-Z □r

→ Flow direction

Pressure (bar) & Flow NO

Size	Orifice (mm)	Pressure (bar)		Kv (l/min)
		AC	DC	
1/4"	8	0 to 8	0 to 8	12
1/2"	12	0 to 8	0 to 8	20

Voltage & Power Consumption

V	AC (W)						DC (W)		
	50 Hz			60 Hz					
	8	5.5	2.5	8	5.5	2.5	10	5.5	3.5
6							•		
12	•			•			•		
24	•			•			•		
48	•			•			•		
110	•			•			•		
120	•			•					
220	•			•			•		
230	•			•					
240	•			•			•		

- Available options

GEM-SOL® | Z32 (GEM-Z) | Zero Differential Pressure 1/4"-3/4" 2 Way NC, NO

Dimensions

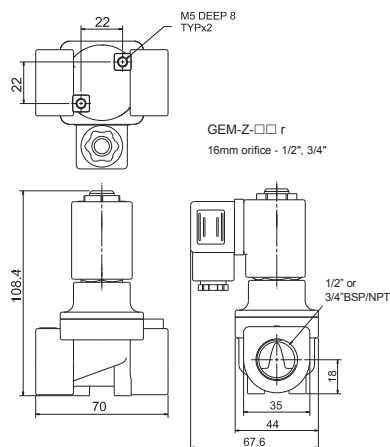
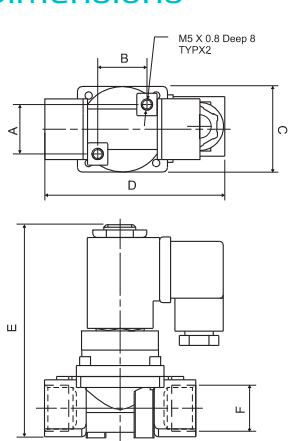

Size	A	B	C	D	E	F	Weight with coil
1/4"	22	22	32	58	89	1/4" BSP/NPT	415gr.
1/2"	22	22	38	70	95	1/2" BSP/NPT	530gr.

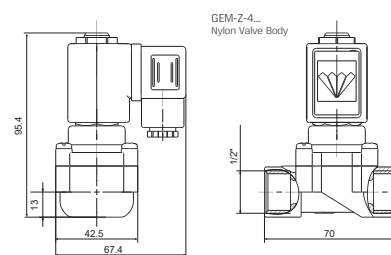

How to Order

* When ordering without coil, please define what current and pressure rating is needed (DC, AC)

GEM-Z	BODY	PORT	FUNCTION	SEALS	VOLTAGE	POWER	CONNECTOR					
	Brass 2	1/4" BSP	20	2W NC 1 NBR N	W/out coil 0	No coil 0	with 1					
	Stainless Steel 3	1/4" NPT	21	2W NO* (5) 2a FKM V	6 (6) 1	AC8W 50Hz 1	with LED 2					
	Plastic (1) 4	1/2" BSP	40	EPDM E	12	2	AC8W 60Hz 2	12	2	AC8W 60Hz 2	2	with LED 2
		1/2" NPT	41		24	3	DC10W 3	3	with 1/2" Hub 5			
		1/2" BSP* (2) (3)	40r		48	4			surge protection with LED* 6			
		1/2" NPT *(2) (3)	41r		110	5			connector with moulded cable 7			
		3/4" BSP*(3) (4)	50r		120	6			other 9			
		3/4" NPT*(3) (4)	51r		220	7A						
					230	7						
					240	8						
					Latch/ other (7)	9						

* SPECIAL OPTIONS | Extended lead times, Non-stock items, MOQ may be applicable

Example: GEM-Z-2401N-221

GEM-SOL® Z32 (GEM-Z) Zero Differential, Brass, 1/2" BSP, 2W NC, NBR, 12V AC8W 60Hz with connector

(1) Only available in 1/2"

(2) Not available in Stainless Steel

(3) 16mm orifice

(4) Only for Stainless Steel 16mm orifice

(5) NO function without M/O, not available for GEM-Z-□□r

(6) DC only

(7) For specifying Latch type coil, please refer to A3P32 (GEM-A3P) valve - How to Order table

* To order valves manufactured according to your specific requirements, please contact our technical sales department

ELECTRIC & HYDRAULIC VALVES

GEM-FLOW™ | G75-S

Hydraulic 3/4"- 2" 2 Way

Technical Data

Function	2 Way
Ports size	3/4", 1", 1-1/2", 2" BSPT & NPT
Pressure range	0.3 to 10bar
Temperature range	Fluid: 5°C to 50°C (no freezing)
Materials in contact with media	Main Valve: Plastic (Reinforced Nylon) Diaphragm: NR : 3/4", 1" EPDM : 1-1/2", 2" Seals: Buna - N Spring: Stainless Steel AISI 300 series



No inline pilot port | with flow control



Upstream inline pilot port | with flow control

Head Loss for Fully Open Valve

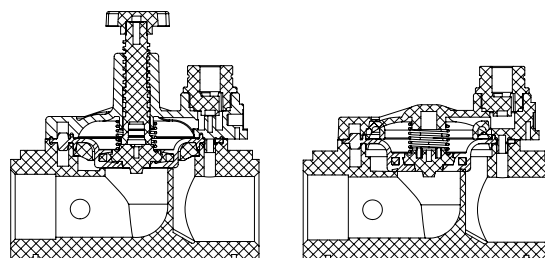
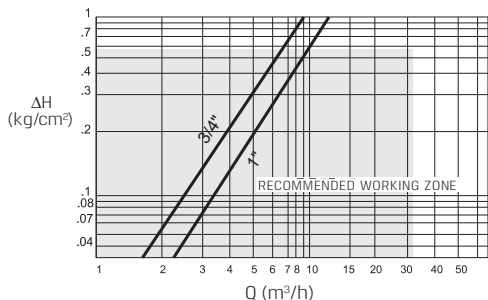

Flow direction →
with flow control without flow control

Head Loss for Fully Open Valve

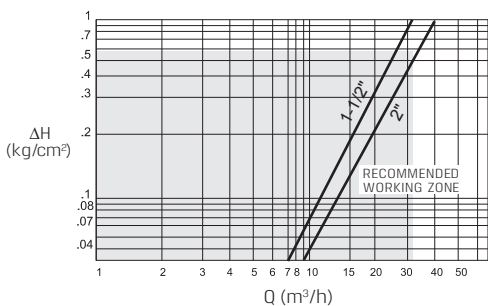

GEM-FLOW™ | G75-S | Hydraulic 3/4"- 2" 2 Way

Dimensions

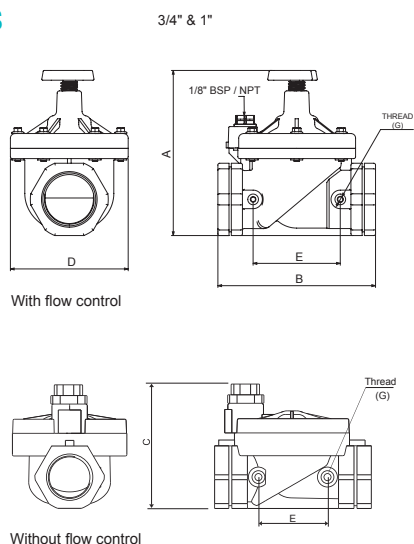

Size	A	B	C	D	E	ØG	Weight (gr.)
3/4"	105	110	77	81	52.5	1/8"NPT/BSP	230
1"	112	110	84	81	48.5	1/8"NPT/BSP	230
1-1/2"	180	160	98	127	92	1/4"NPT/BSP	740
2"	190	170	98	127	94	1/4"NPT/BSP	790

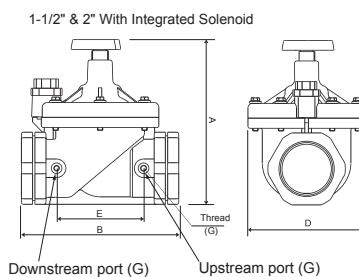

How to Order

G75-S	PORT	FUNCTION INLINE PILOT PORTS	FLOW CONTROL
3/4" BSPT	50	none	0 with 5
3/4" NPT	51	upstream only	1 without ⁽¹⁾ 6
1" BSPT	60	downstream only	2
1" NPT	61	both	3
1-1/2" BSPT	70		
1-1/2" NPT	71		
2" BSPT	80		
2" NPT	81		

Example: G75-S-5015

GEM-FLOW™ G75-S Hydraulic valve, 3/4" BSPT, 1/8" upstream inline pilot port, with flow control

(1) 3/4", 1" valves only

* To order valves manufactured according to your specific requirements, please contact our technical sales department

ELECTRIC & HYDRAULIC VALVES

GEM-FLOW™ | G75-S

3 Way Integral Solenoid Pilot Control 3/4" - 2" NC

Technical Data

Solenoid	Supplied with 3 Way NO 1.2mm G75 operator
Assembly	Upstream pilot control valve is supplied with finger filter and accessories

- For technical information, refer to G75-S | Electric 3/4" - 2" 2 Way NC

Voltage & Power Consumption

V	AC (W)	DC(W)
	50 Hz	
12	•	•
24	•	•

- Available options

Voltage & Current

AC & DC

Solenoid	Voltage	Inrush [A]	Holding [A]
2 Way 50 Hz	V +10% n-20%	0.3	0.19
2 Way 60 Hz		0.2	0.14
3 Way 50/60 Hz *		0.125	0.125
DC		4.5W	

- * Except 24V AC without Diode

Latch Coil Resistance vs Input Voltage

Recommendations chart

Resistance [Ω]	Input voltage range [V]
4	6 - 9
9	12 - 14
12	14 - 16
23	18 - 21

How to Order

G75-S	PORT	FUNCTION	MANUAL OVERRIDE	FLOW CONTROL	VOLTAGE (3)	WIRES
	3/4" BSPT 50	External pilot	4 None	0 with	5 24V AC	1 two null
	3/4" NPT 51	Upstream pilot	4H Plastic	1 without(1)	6 24V AC w/out Diode	1R three(2) a
	1" BSPT 60		Handle(2)	2	12 V AC	3
	1" NPT 61				12 V DC	4
	1-1/2" BSPT 70				24V DC	5
	1-1/2" NPT 71				23Ω	6
	2" BSPT 80				4Ω	B
	2" NPT 81				9Ω	C
					12Ω	D

Example: G75-S-704151

GEM-FLOW™ G75-S 1-1/2" BSPT, external pilot, plastic manual override, with flow control, 24V AC, two wires

(1) For 3/4", 1" valves only

(2) For Latch only

(3) For Latch: Refer to Latch Coil Resistance vs Input Voltage | Recommendations chart



Upstream pilot control

External pilot control

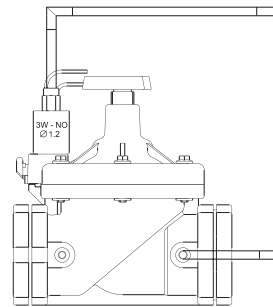

Upstream pilot control

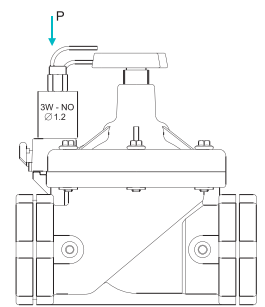

External pilot control

* To order valves manufactured according to your specific requirements, please contact our technical sales department

GEM-FLOW™ | G75-SE

3 Way External Solenoid Pilot Control 3/4" - 2" NC, NO

Technical Data

Solenoid	Supplied with 3 Way 1.2mm G75 solenoid or G75-A3P 2.6 mm latch
Assembly	Supplied with finger filter and accessories

- For technical information, refer to G75-S | Electric 3/4" - 2" 2 Way NC

Voltage & Power Consumption

V	AC (W)	DC(W)
	50 Hz	
12	•	•
24	•	•

- Available options

Voltage & Current

AC & DC

Solenoid	Voltage	Inrush [A]	Holding [A]
2 Way 50 Hz	V +10% n-20%	0.3	0.19
2 Way 60 Hz		0.2	0.14
3 Way 50/60 Hz *		0.125	0.125
DC		4.5W	

- * Except 24V AC without Diode



NC valve

NO valve

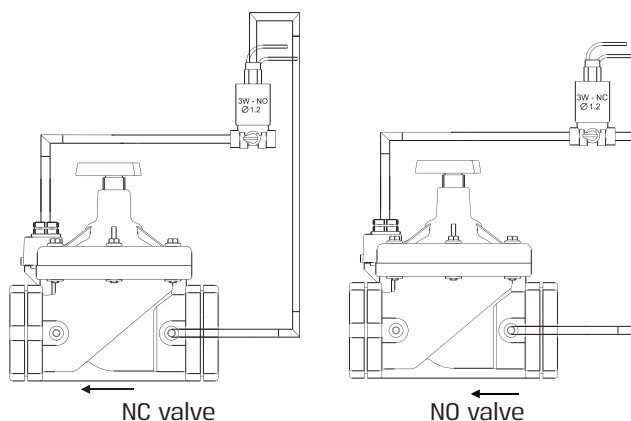

NC valve

NO valve

How to Order

G75-SE -	PORT	FUNCTION ⁽³⁾	MANUAL OVERRIDE	FLOW CONTROL	VOLTAGE ⁽⁴⁾	WIRES
	3/4" BSPT 50	2W NC 1	None 0	with 5	24V AC 1	two null
	3/4" NPT 51	2W NO 2	Plastic 1	without ⁽¹⁾ 6	24V AC w/out Diode 1R	three ⁽²⁾ a
	1" BSPT 60				12 V AC 3	
	1" NPT 61				12 V DC 4	
	1-1/2" BSPT 70				24V DC 5	
	1-1/2" NPT 71				23Ω 6	
	2" BSPT 80				4Ω B	
	2" NPT 81				9Ω C	
					12Ω D	
					1Ω ⁽⁵⁾ PA	
					4Ω ⁽⁵⁾ PB	
					9Ω ⁽⁵⁾ PC	

Example: G75-SE-702151

GEM-FLOW™ G75-SE 1-1/2" BSPT, 2W NO, plastic manual override, with flow control, 24V AC, two wires

(1) For 3/4", 1" valves only

(2) For Latch only

(3) Refers to the valve:

3 Way NC solenoid = NO valve

3 Way NO solenoid = NC valve

(4) For Latch: Refer to Latch Coil Resistance vs Input Voltage | Recommendations chart

(5) For G75-A3P Latch

Latch Coil Resistance vs Input Voltage

Recommendations chart

G75-A Latch	
Resistance [Ω]	Input voltage range [V]
4	6 - 9
9	12 - 14
12	14 - 16
23	18 - 21
G75-A3P Latch	
Resistance [Ω]	Input voltage range [V]
1	8 - 12
4	12 - 18
9	18 - 24

* To order valves manufactured according to your specific requirements, please contact our technical sales department

ELECTRIC & HYDRAULIC VALVES

GEM-FLOW™ | G75

3 Way Manual Selector 3/4" - 2" NC, NO

Technical Data

Solenoid	Supplied with 3 Way 12mm G75 solenoid or G75-A3P 2.6 mm latch
Assembly	Supplied with finger filter and accessories
Manual override	Manual override with 3 positions: <ul style="list-style-type: none"> • AUTO - for automatic operation (valve is open when solenoid is energized) • MANUAL - valve is kept open • CLOSE - valve is kept closed
Pressure	A minimum pressure differential of 1 bar is required

• For technical information, refer to G75-S | Electric 3/4" - 2" 2 Way NC



3 Way Manual selector

With solenoid

Voltage & Power Consumption

	AC (W)	
	50 Hz	DC(W)
V	2	4.5
12	•	•
24	•	•

• Available options

Voltage & Current

AC & DC

Solenoid	Voltage	Inrush [A]	Holding [A]
2 Way 50 Hz	V +10% n-20%	0.3	0.19
2 Way 60 Hz		0.2	0.14
3 Way 50/60 Hz *		0.125	0.125
DC		4.5W	

* Except 24V AC without Diode

Latch Coil Resistance vs Input Voltage

Recommendations chart

G75-A Latch	
Resistance [Ω]	Input voltage range [V]
4	6 - 9
9	12 - 14
12	14 - 16
23	18 - 21
G75-A3P Latch	
Resistance [Ω]	Input voltage range [V]
1	8 - 12
4	12 - 18
9	18 - 24

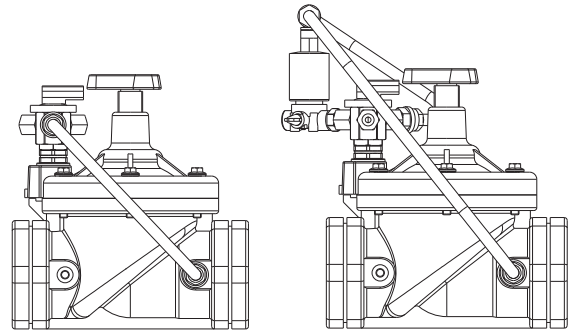

← Flow direction

3 Way Manual selector

Manual selector with external 3 Way NO solenoid

How to Order

G75	TYPE	PORT	FUNCTION ⁽¹⁾	FLOW CONTROL	VOLTAGE ⁽⁴⁾	WIRES	
	Hydraulic with Manual Selector	SM	3/4" BSPT 50	2W NC 1	with 5	No solenoid (hydraulic) 0	two null
	Electric	EL	3/4" NPT 51	2W NO 2	without ⁽²⁾ 6	24V AC 1	three ⁽³⁾ a
	Electric with Manual Selector	ELM	1" BSPT 60			24V AC w/out Diode 1R	
			1" NPT 61			12V AC 3	
			1-1/2" BSPT 70			12V DC 4	
			1-1/2" NPT 71			24V DC 5	
			2" BSPT 80			23Ω 6	
			2" NPT 81			4Ω B	
						9Ω C	
						12Ω D	
						1Ω ⁽⁵⁾ PA	
						4Ω ⁽⁵⁾ PB	
						9Ω ⁽⁵⁾ PC	

Example: G75-ELM-70151

GEM-FLOW™ G75 3 Way electric with manual selector, 1-1/2" BSPT, 2W NC with flow control, 24V AC, two wires

- (1) Refers to the valve:
3 Way NC solenoid = NO valve
3 Way NO solenoid = NC valve
- (2) For 3/4", 1" valves only
- (3) For Latch only
- (4) For Latch: Refer to Latch Coil Resistance vs Input Voltage | Recommendations chart
- (5) For G75-A3P Latch

* To order valves manufactured according to your specific requirements, please contact our technical sales department

GEM-FLOW™ | G75

Pressure Reducing 3/4" - 2" 2 Way NC

Technical Data

Solenoid	Supplied with 3 Way NO 12mm G75 solenoid or G75-A3P 2.6 mm latch
Assembly	Supplied with finger filter
Pressure	<ul style="list-style-type: none"> Pilot pressure must be equal to, or higher than line pressure A minimum pressure differential of 1 bar is required

- For technical information, refer to G75-S | Electric 3/4" - 2" 2 Way NC

Voltage & Power Consumption

	AC (W) 50 Hz	DC(W)
V	2	4.5
12	•	•
24	•	•

- Available options

Voltage & Current

AC & DC

Solenoid	Voltage	Inrush [A]	Holding [A]
2 Way 50 Hz	+10%	0.3	0.19
2 Way 60 Hz		0.2	0.14
3 Way 50/60 Hz *	n-20%	0.125	0.125
DC		4.5W	

- * Except 24V AC without Diode



Pressure reducing | 0.5-5 bar / 1-10 bar

Latch Coil Resistance vs Input Voltage

Recommendations chart

G75-A Latch	
Resistance [Ω]	Input voltage range [V]
4	6 - 9
9	12 - 14
12	14 - 16
23	18 - 21
G75-A3P Latch	
Resistance [Ω]	Input voltage range [V]
1	8 - 12
4	12 - 18
9	18 - 24

How to Order

G75	TYPE	PORT	FUNCTION	FLOW CONTROL	VOLTAGE (3)	WIRES	PRESSURE RANGE
	Pressure Reducing PR	3/4" BSPT 50	2W NC 1	with 5	No solenoid (hydraulic) 0	two null	0.5-5 bar Y
	With Manual Selector PRM	3/4" NPT 51		without(1) 6	24V AC 1	three(2) a	1-10 bar G
	Electric Without Manual Selector PREL	1" BSPT 60			24V AC w/out Diode 1R		
	Electric With Manual Selector PRELM	1" NPT 61			12V AC 3		
		1-1/2" BSPT 70			12V DC 4		
		1-1/2" NPT 71			24V DC 5		
		2" BSPT 80			23Ω 6		
		2" NPT 81			4Ω B		
					9Ω C		
					12Ω D		
					1Ω (4) PA		
					4Ω (4) PB		
					9Ω (4) PC		

Example: G75-PR-70151Y

GEM-FLOW™ G75 pressure reducing valve, 1-1/2" BSPT, 2W NC with flow control, 24V AC, two wires, 0.5-5 bar

- (1) For 3/4", 1" valves only
- (2) For Latch only
- (3) For Latch: Refer to Latch Coil Resistance vs Input Voltage | Recommendations chart
- (4) For G75-A3P Latch

Pressure Reducing | PR

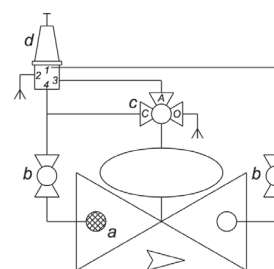

* To order valves manufactured according to your specific requirements, please contact our technical sales department

b **BACCARA**[®]
AUTOMATION & CONTROL



ELECTRIC & HYDRAULIC

VALVES | G500

GEM-FLOW™ 500 Series	Hydraulic Control Valves.....	60
GEM-FLOW™	Operating Principals.....	61
GEM-FLOW™	Available Models.....	62
GEM-FLOW™	Hydraulic Performance.....	63
GEM-FLOW™ G500	4" Hydraulic Valves.....	64
GEM-FLOW™ G500-S	Hydraulic with Manual Selector 1-1/2" - 4".....	66
GEM-FLOW™ G500-EL	Electric Solenoid Control Valve 1-1/2" - 4".....	67
GEM-FLOW™ G500-C	DC Battery Controller 1-1/2" - 4".....	68
GEM-FLOW™ G500-PR	Pressure Reducing 1-1/2" - 4".....	69
GEM-FLOW™ G500-PREL	Solenoid Controlled Pressure Reducing 1-1/2" - 4".....	70
GEM-FLOW™ G500-PRPS	Pressure Reducing & Sustaining Control Valve 1-1/2" - 4".....	71
GEM-FLOW™ G500-QR	Quick Pressure Relief 1-1/2" - 4".....	72
GEM-FLOW™ G500-PS	Pressure Sustaining Control Valve 1-1/2" - 4".....	73



GEM-FLOW™ | 500 Series

Hydraulic Control Valves

General Description

500 series valves are direct diaphragm closing automatic hydraulic control valves which work with line pressure. They ensure easy and smooth flow with minimum pressure losses thanks to excellent design of the valve body and diaphragm. No wearable parts such as stem, bearing and seat exist in the main valve body and valve life is much longer than other competitor valves. The only movable part of the valve is the valve diaphragm.

500 series hydraulic control valves are designed so that they can be used in portable water force network, agricultural irrigation, filtration and industrial applications by even unskilled personnel.

General Features

- Easy use and maintenance due to simple design
- Low cost
- Operation in wide pressure range
- Perfect modulation even in lower flow rates
- Anti-surge closing and opening with flexible diaphragm
- Full tightness thanks to reinforced diaphragm and inner spring
- Long life with Glass Reinforced Polyamide material
- Wide control application range by using different pilot valves
- Operation in both horizontal and vertical positions in application areas



GEM-FLOW™

Operating Principals

It is an automatic hydraulic control valve designed to make desired modulation in main valve network line as full hydraulically by means of line pressure without requiring different energy sources such as electric, pneumatic or mechanical energy.

Valve Opening Mode

When the pilot valve located on the main valve being in closed position, is brought into relief position, pressurized water within control chamber on main valve diaphragm is released. When line pressure (P1) reaches to a value which will overcome spring force, water carries valve to fully open position by applying a hydraulic force to valve diaphragm from bottom.

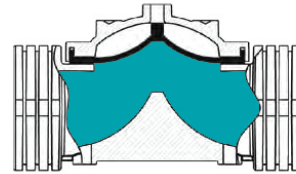

Modulation Mode

Pilot valves which are connected to main valve actuator ensure that main valve works in modulated mode. According to flow rate or pressure conditions, it ensures that main valve works in modulation mode by controlling pressure of fluid within main valve actuator (control chamber).

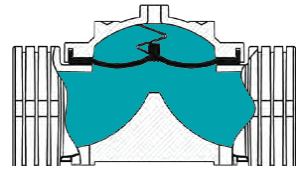

Valve Closing Mode

Pilot valves which are connected to main valve actuator ensure that main valve works in modulated mode. According to flow rate or pressure conditions, it ensures that main valve works in modulation mode by controlling pressure of fluid within main valve actuator (control chamber).

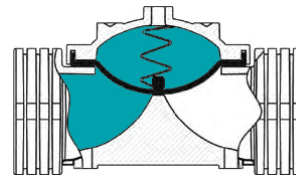



Available Models

Technical Data

Pressure range	Standard	0.7 - 10 bar (10 - 160 psi)
Temperature range	Fluid Ambient	(-10°C to 60°C (no freezing) -10°C to 60°C
Connection	Threaded	BSPT-NPT
Hydraulic connections	Standard	Reinforced Nylon (Air Brake) Hydraulic Pipe-SAE J 844
Actuator type	Standard	Diaphragm Closing Type with Single Control Chamber and Diaphragm Actuator

Available Models

MODEL	G500	
Connection	Threaded	
Material	Glass reinforced polyamide	
Body	Globe	
Maximum working pressure	10 bar	160psi
Available sizes	inch	mm
	1-1/2"	40
	2"	50
	2-1/2"	65
	3"	80

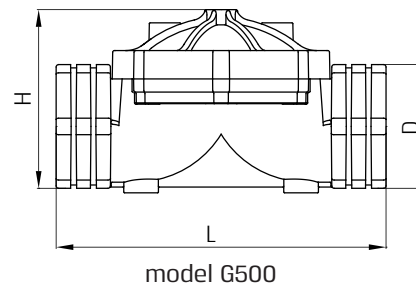

Dimensions

DN		D		L		H	
inch	mm	inch	mm	inch	mm	inch	mm
1-1/2"	40	2-1/2"	62	7-7/8"	200	4-3/8"	110
2"	50	3"	75	7-7/8"	200	4-3/8"	110
2-1/2"	65	3-3/4"	95	9-7/8"	250	5-3/8"	138
3"	80	4-1/4"	109	9-7/8"	250	5-3/8"	145

Order Information

Please submit following information to our sales department when ordering:

- Maximum flow rate.....m3/h
- Maximum network/line pressure.....bar
- Main line size.....mm
- Valve connection type
- Maximum upstream pressure.....bar
- Minimum upstream pressure.....bar
- Desired downstream pressure.....bar
- Electric voltage value to be used.....volt

GEM-FLOW™

Hydraulic Performance

Hydraulic Performance Chart

VALVE SIZE	mm	40	50	65	80
	inch	1-1/2"	2"	2-1/2"	3"
Kv	m³/h @ 1 bar	60	70	80	90
Cv	gpm @ 1 psi	70	85	95	105

- Kv: Valve Flow Coefficient (fluid passing under 1 bar pressure difference in m³/h @ 1 bar)
 - Cv: Valve Flow Coefficient (fluid passing under 1 bar pressure difference in gpm @ 1 bar)
 - Q: Flow Rate (m³/h)
 - ΔP: Head Loss (bar)
 - G: Specific weight of water (1.0 for water)
- $$Kv, (Cv) = Q \sqrt{\frac{G}{\Delta P}}$$
- $$Cv = 1,155 Kv$$

Head Loss Chart

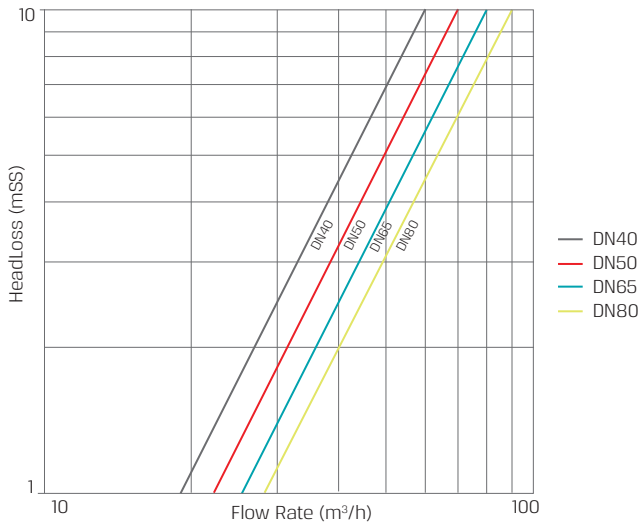

Main Parts

NO.	PART NAME	MATERIAL
1	Body	Glass reinforced polyamide
2	Bonnet	Glass reinforced polyamide
3	Diaphragm	Natural Rubber
4	Spring thrust ring	Glass reinforced polyamide
5	Spring	SST302
6	Bolt	SST304
7	Nut	Brass

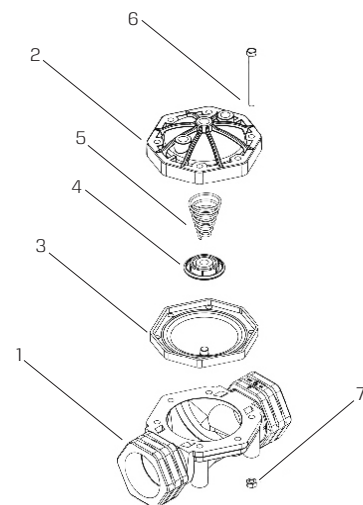

GEM-FLOW™ | G500

4" Hydraulic Valves

Typical Applications

- Agricultural irrigation
- Landscaping applications
- Greenhouse applications
- Mining process
- Industrial process

Technical Data

General Specifications	
Pressure range	0.7-10 bar / 9-145 Psi
Temperature range	-10°C to 80°C (no freezing)
Valve size	4" (100 mm)
Material Properties	
Body Cover	PA GFR
Diaphragm	NR
Spring thrust ring	PA GFR
Spring	Stainless Steel AISI 302
Bolts	Stainless Steel A2
Flange, Flange adaptor	PA GFR
Threaded adaptor	PA GFR
O-rings	NBR
Connection	
Flanged	ISO, ANSI
Threaded	BSP, NPT



Head Loss Chart

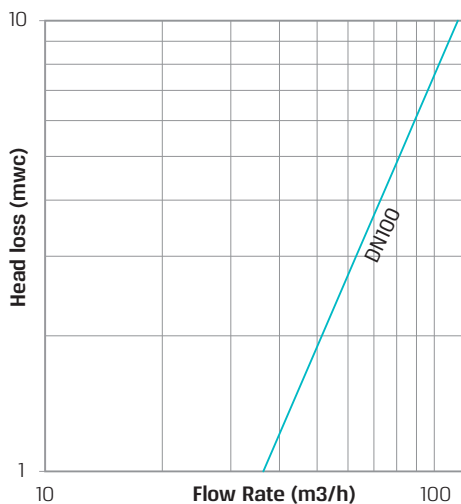

GEM-FLOW™ | G500 | 4" Hydraulic Valves

Hydraulic Specifications

Maximum continuous flow	100 m ³ /h
Maximum intermittent flow	145 m ³ /h
Minimum working pressure	0.7 bar
Maximum working pressure	10 bar
Kv	115 m ³ /h @ 1 bar

Dimensions

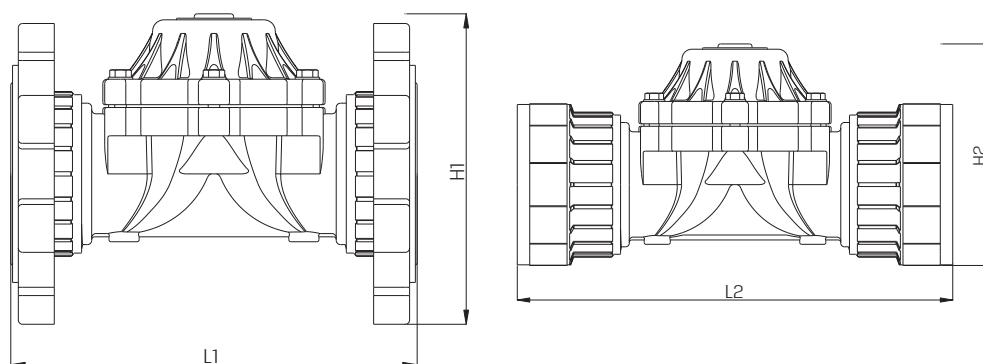

L1	280 mm
L2	350 mm
H1	220 mm
H2	180 mm
W1	213 mm
W2	172 mm
Port Connections	1/4" BSP, 1/4" NPT
Weight (Flange type)	2.6 kg
Weight (Threaded type)	1.9 kg

Available Applications

Basic valve	B
Manual control valve	M
Solenoid control valve	EL
Electric control valve + control device (1 outlet)	EL/C
Pressure reducing control valve	PR
Solenoid controlled pressure reducing valve	PREL
Pressure reducing & sustaining control valve	PRPS
Quick pressure relief control valve	QR
Pressure sustaining valve	PS
Float level control valve	FL
Electric float level control valve	FLEL
Flow rate control valve	FR

GEM-FLOW™ | G500-S

Hydraulic with Manual Selector 1-1/2" - 4"

Description

G500-S model valve is the hydraulic control valve operated by line pressure and designed to ensure opening/closing process by means of a 3 Way selector valve. Minimum opening pressure of valve is 0.7 bar. Thanks to its flexible diaphragm, it makes easy and fast control process in high pressure applications and is closed completely tight without causing surge. It may be used in different applications by adding different pilot valves on its main body.

Applications

- Use G500-S for local operation of hydraulic valve by a manual command
- Use G500-S for water distribution and field

Standards

- G500-S: manual control valve with 3 Way selector valve, polyethylene plastic tubing and nylon fittings

How to Order

G500	-	TYPE	-	PORT	
G500	-	Hydraulic with Manual Selector	S	1-1/2" BSPT	70
			SM	1-1/2" NPT	71
				2" BSPT	80
				2" NPT	81
				2-1/2" BSPT	85
				2-1/2" NPT	86
				3" BSPT	90
				3" NPT	91
				4" BSPT	100
				4" NPT	101
			4" Flange	100F	

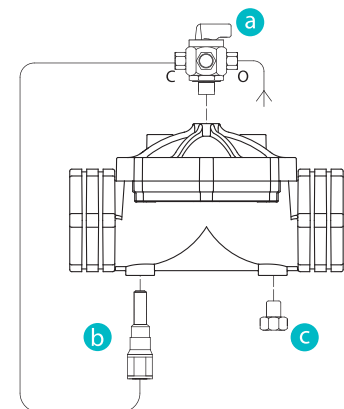

- a 3W selector valve
- b In-line finger filter
- c Plug

Example: G500-SM-80

GEM-FLOW™ G500 Hydraulic with manual selector, 2" BSPT

* To order valves manufactured according to your specific requirements, please contact our technical sales department

GEM-FLOW™ | G500-EL

Electric Solenoid Control Valve 1-1/2" - 4"

Description

G500-EL model valve is the hydraulic control valve operated by line pressure and designed to ensure opening/closing process by means of built-in 3 Way solenoid pilot valve controlled remotely with electric signal*. Electric signal for solenoid pilot valve is ensured by means of a control device, time relay, main switch and PLC control units etc. Opening/Closing process may be realized easily thanks to manual control on solenoid pilot valve, depending on requirements, 24V AC 50Hz/60Hz or 12V DC, 9V Latch and 12V DC Latch normally open (NO) or normally closed (NC), solenoids coils may be used on main valve.

* For technical information, refer to G75-A and G75-A3P solenoid valves

Applications

- Use G500-EL to remove operation of hydraulic valve by an electric command
- Use G500-EL for water distribution

Standards

- G500-EL: 3 Way NO Solenoid, polyethylene plastic tubing system and nylon fittings
- G500-ELM: 3 Way NO Solenoid, polyethylene plastic tubing system, nylon fittings and 3 Way selector

How to Order

G500	-	TYPE		PORT		VOLTAGE		WIRES	
		Electric	EL	1-1/2" BSPT	70	No solenoid (hydraulic)	0	two	null
		with Manual Selector	ELM	1-1/2" NPT	71	24V AC	1	three ⁽²⁾	a
				2" BSPT	80	24V AC w/out Diode	1R		
				2" NPT	81	12V AC	3		
				2-1/2" BSPT	85	12V DC	4		
				2-1/2" NPT	86	24V DC	5		
				3" BSPT	90	23Ω	6		
				3" NPT	91	4Ω	B		
				4" BSPT	100	9Ω	C		
				4" NPT	101	12Ω	D		
				4" Flange	100F	1Ω ⁽¹⁾	PA		
						4Ω ⁽¹⁾	PB		
						9Ω ⁽¹⁾	PC		

Example: G500-ELM-801

GEM-FLOW™ G500 Electric with manual selector, 2" BSPT, 24V AC, two wires

- (1) For G75-A3P Latch
 (2) For Latch only

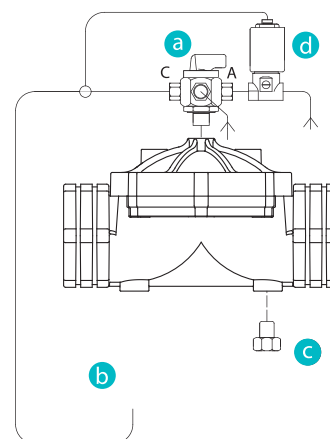

- a 3W selector valve
- b In-line finger filter
- c Plug
- d Solenoid Pilot Valve

* To order valves manufactured according to your specific requirements, please contact our technical sales department

GEM-FLOW™ | G500-C

DC Battery Controller 1-1/2" - 4"

Description

G500-C model valve is the hydraulic control valve operated by line pressure and designed to ensure opening/closing process by means of built-in solenoid pilot valve controlled remotely with electric signal at required time or required duration. Electric signal for solenoid pilot valve is ensured by means of a control device, time relay, main switch and PLC control units etc. Opening/ Closing process may be realized easily thanks to manual control on solenoid pilot valve, depending on requirements. The controller irrigates in cycles, during a window of time according to your needs.

Applications

- Use G500-C for programmed irrigation
- Use G500-C for water distribution

Standards

- G500-C: 9V DC Latch solenoid, Control Unit (1 Outlet), polyethylene plastic tubing system, nylon fittings and 3 Way selector

How to Order

G500-C	-	TYPE	-	PORT	
		One valve	null	1-1/2" BSPT	70
		Window	W	1-1/2" NPT	71
		Window +	W+	2" BSPT	80
				2" NPT	81
				2-1/2" BSPT	85
				2-1/2" NPT	86
				3" BSPT	90
				3" NPT	91
				4" BSPT	100
				4" NPT	101
				4" Flange	100F

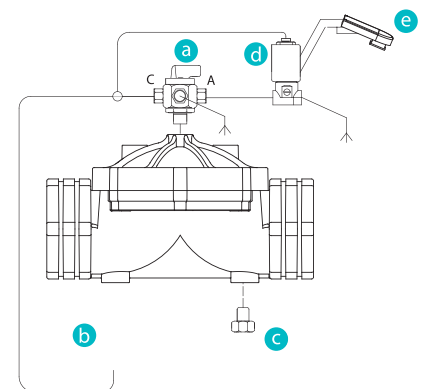

- a 3W selector valve
- b In-line finger filter
- c Plug
- d Solenoid Pilot Valve
- e Controller

Example: G500-C-W-90

GEM-FLOW™ G500 DC Battery controller, Window, 3" BSPT

* To order valves manufactured according to your specific requirements, please contact our technical sales department

GEM-FLOW™ | G500-PR

Pressure Reducing 1-1/2" - 4"

Description

G500-PR model pressure reducing control valve is the hydraulic control valve which reduces high upstream pressure value to desired lower pressure value by means of built-in pressure reducing pilot valve. Pressure reducing control valve controls downstream pressure value continuously and maintains it constant without being affected from flow rate and upstream pressure values. When no flow exists in the system, it closes itself automatically. When valve upstream pressure value is lower than set point, it is opened fully by itself. Valve may be used in vertical or horizontal positions in the system.



Applications

- Use G500-PR for irrigation, water distribution and filtration systems
- Smart designed G500-PR provides high corrosion resistance

Standards

- G500-PR: 3 Way plastic pressure reducing pilot, polyethylene plastic tubing system and nylon fittings
- G500-PRM: 3 Way plastic pressure reducing pilot, polyethylene plastic tubing system, nylon fittings and 3 Way selector
- Standard pressure adjustment from factory: 2.5 bar

How to Order

G500	TYPE	PORT	PRESSURE RANGE
without Manual Selector	PR	1-1/2" BSPT 70	0.5-5 bar Y
with Manual Selector	PRM	1-1/2" NPT 71	1-10 bar G
		2" BSPT 80	
		2" NPT 81	
		2-1/2" BSPT 85	
		2-1/2" NPT 86	
		3" BSPT 90	
		3" NPT 91	
		4" BSPT 100	
		4" NPT 101	
		4" Flange 100F	

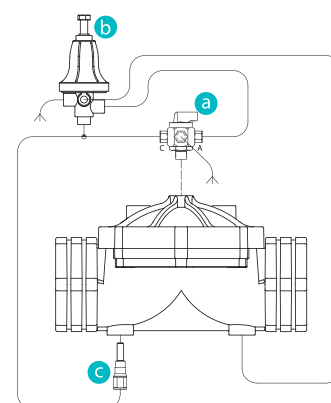

- a 3W selector valve
- b Plastic Pilot
- c In-line finger filter

Example: G500-PR-80G

GEM-FLOW™ G500 pressure reducing without manual selector, 2" BSPT, 1-10 bar

* To order valves manufactured according to your specific requirements, please contact our technical sales department

GEM-FLOW™ | G500-PREL

Solenoid Controlled Pressure Reducing 1-1/2" - 4"

Description

G500-PREL model pressure reducing valve is the hydraulic control valve which reduces high upstream pressure value into desired lower pressure value. Control of main valve is achieved by means of built-in solenoid pilot valves*. Electric signal for solenoid pilot valves is ensured by means of a control device, time relay, main switch and PLC control units etc. Automated control may be easily ensured by this way in application systems.

* For technical information, refer to G75-A and G75-A3P solenoid valves

Applications

- Use G500-PREL for water distribution, where downstream pressure should be reduced, the valve is commanded to open

Standards

- G500-PREL: 3 Way plastic pressure reducing pilot, solenoid 24V AC NO, polyethylene plastic tubing system and nylon fittings
- G500-PRELM: 3 Way plastic pressure reducing pilot, solenoid 24V AC NO, polyethylene plastic tubing system and nylon fittings and 3 Way selector
- Standard pressure adjustment from factory: 2.5 bar

How to Order

G500	-	TYPE	-	PORT	VOLTAGE	WIRES	PRESSURE RANGE
		without Manual Selector	PREL	1-1/2" BSPT 70	No solenoid (hydraulic)	two null	0.5-5 bar Y
		with Manual Selector	PRELM	1-1/2" NPT 71	24V AC	three ⁽²⁾ a	1-10 bar G
				2" BSPT 80	24V AC w/out Diode	1R	
				2" NPT 81	12V AC	3	
				2-1/2" BSPT 85	12V DC	4	
				2-1/2" NPT 86	24V DC	5	
				3" BSPT 90	23Ω	6	
				3" NPT 91	4Ω	B	
				4" BSPT 100	9Ω	C	
				4" NPT 101	12Ω	D	
				4" Flange 100F	1Ω ⁽¹⁾	PA	
					4Ω ⁽¹⁾	PB	
					9Ω ⁽¹⁾	PC	

Example: G500-PRELM-851G

GEM-FLOW™ G500 Solenoid controlled pressure reducing, with manual selector, 2-1/2" BSPT, 24V AC, two wires, 1-10 bar

- (1) For G75-A3P Latch
- (2) For Latch only

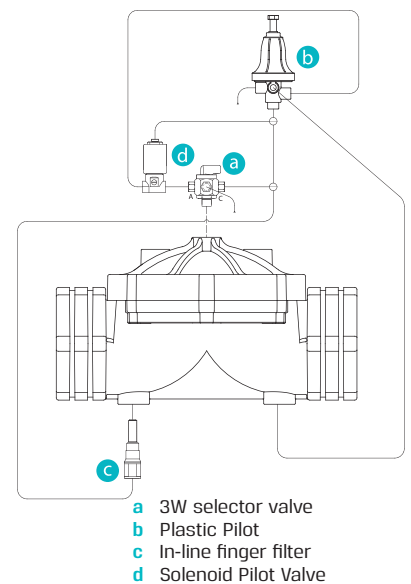

* To order valves manufactured according to your specific requirements, please contact our technical sales department

GEM-FLOW™ | G500-PRPS

Pressure Reducing & Sustaining Control Valve 1-1/2" - 4"

Description

G500-PRPS model pressure reducing/sustaining hydraulic control valve reduces valve downstream pressure to desired value by sustaining upstream pressure. Two pilot valves exist on the valve. Pilot valve on upstream side is the pressure sustaining pilot valve and sustains upstream pressure. The other pilot valve is pressure reducing pilot valve and keeps downstream pressure constant by reducing it to desired value. Reducing/sustaining control valve pumps fluid downwards; it ensures that the system works within normal values by regulating overflow and high pressure in pumping systems. It controls upstream and downstream pressure continuously and keeps them within constant values.



Applications

- Use G500-PRPS for protecting booster pumps and preserving set pressure downstream

Standards

- G500-PRPS: 3 Way plastic pressure reducing pilot, 3 Way plastic pressure sustaining valve, polyethylene plastic tubing system, nylon fittings and 3 Way selector

How to Order

G500-PRPS	-	PORT		PRESSURE RANGE	
		1-1/2" BSPT	70	0.5-5 bar	Y
		1-1/2" NPT	71	1-10 bar	G
		2" BSPT	80		
		2" NPT	81		
		2-1/2" BSPT	85		
		2-1/2" NPT	86		
		3" BSPT	90		
		3" NPT	91		
		4" BSPT	100		
		4" NPT	101		
		4" Flange	100F		

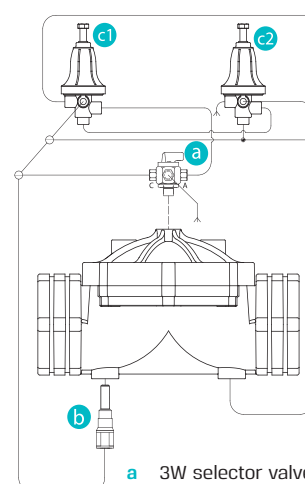

- a 3W selector valve
- b In-line finger filter
- c1 Plastic Pressure Sustaining Pilot
- c2 Plastic Pressure Reducing Pilot

Example: G500-PRPS-80G

GEM-FLOW™ G500 pressure reducing & sustaining 2" BSPT, 1-10 bar

* To order valves manufactured according to your specific requirements, please contact our technical sales department

GEM-FLOW™ | G500-QR

Quick Pressure Relief 1-1/2" - 4"

Description

G500-QR model quick pressure relief valve is the safety control valve designed to protect the system by releasing pressure surges, which are caused by sudden changes in water speed due to pumps put into/out of service, in water network elevation lines to the atmosphere quickly. When network pressure exceeds set point, the valve opens by itself quickly and protects the system by releasing over pressure. When the line pressure decreases to normal level, it is tightly closed slowly and automatically without causing a surge.

* For technical information, refer to G75-A and G75-A3P solenoid valves



Applications

- Use G500-QR when wishing to avoid unwanted high pressure

Standards

- G500-QR: 3 Way plastic pilot, polyethylene plastic tubing system and nylon fittings
- G500-QRM: 3 Way plastic pilot, polyethylene plastic tubing system and nylon fittings and 3 Way selector

How to Order

G500	TYPE	PORT	VOLTAGE	WIRES	PRESSURE RANGE
	without Manual Selector QR	1-1/2" BSPT 70	No solenoid (hydraulic) 0	two null	0.5-5 bar Y
	with Manual Selector QRM	1-1/2" NPT 71	24V AC 1	three ⁽²⁾ a	1-10 bar G
		2" BSPT 80	24V AC w/out Diode 1R		
		2" NPT 81	12V AC 3		
		2-1/2" BSPT 85	12V DC 4		
		2-1/2" NPT 86	24V DC 5		
		3" BSPT 90	23Ω 6		
		3" NPT 91	4Ω B		
		4" BSPT 100	9Ω C		
		4" NPT 101	12Ω D		
		4" Flange 100F	1Ω ⁽¹⁾ PA		
			4Ω ⁽¹⁾ PB		
			9Ω ⁽¹⁾ PC		

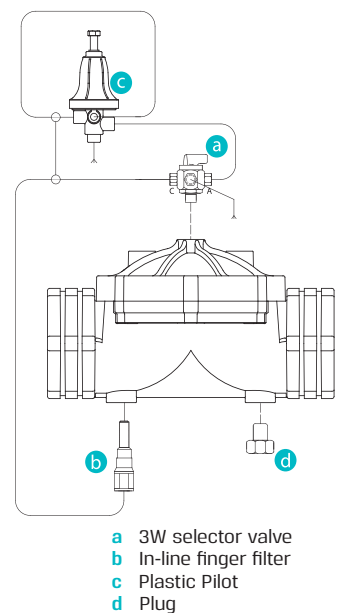

Example: G500-QR-701G

GEM-FLOW™ G500 quick pressure relief, without manual selector, 1-1/2" BSPT, 24V AC, two wires, 1-10 bar

(1) For G75-A3P Latch
 (2) For Latch only

* To order valves manufactured according to your specific requirements, please contact our technical sales department

GEM-FLOW™ | G500-PS

Pressure Sustaining Control Valve 1-1/2" - 4"

Description

G500-PS model pressure sustaining hydraulic control valve maintains valve upstream pressure value constant. Valve is opened when line pressure reaches the preset pressure level. It ensures that pump motor within pumping systems will start without load. It also prevents positive pressure waves caused by pump during start-up. The valve controls upstream pressure value continuously and keeps it at a constant value without being affected from changes in flow rate. When no flow exists, it closes tightly by itself.

* For technical information, refer to G75-A and G75-A3P solenoid valves



Applications

- Use G500-PS for maintaining a constant upstream pressure or to avoid unwanted high pressure

Standards

- G500-PS: 3 Way plastic pressure sustaining pilot, polyethylene plastic tubing system and nylon fittings
- G500-PSM: 3 Way plastic pressure sustaining pilot, polyethylene plastic tubing system, nylon fittings and 3 Way selector
- Standard pressure adjustment from factory: 2.5 bar

How to Order

G500	TYPE	PORT	VOLTAGE	WIRES	PRESSURE RANGE
without Manual Selector	PS	1-1/2" BSPT 70	No solenoid (hydraulic)	0	0.5-5 bar Y
with Manual Selector	PSM	1-1/2" NPT 71	24V AC	1	1-10 bar G
		2" BSPT 80	24V AC w/out Diode	1R	
		2" NPT 81	12V AC	3	
		2-1/2" BSPT 85	12V DC	4	
		2-1/2" NPT 86	24V DC	5	
		3" BSPT 90	23Ω	6	
		3" NPT 91	4Ω	B	
		4" BSPT 100	9Ω	C	
		4" NPT 101	12Ω	D	
		4" Flange 100F	1Ω ⁽¹⁾	PA	
			4Ω ⁽¹⁾	PB	
			9Ω ⁽¹⁾	PC	

Example: G500-PSM-801G

GEM-FLOW™ G500 pressure sustaining with manual selector, 2" BSPT, 24V AC, two wires, 1-10 bar

(1) For G75-A3P Latch
(2) For Latch only

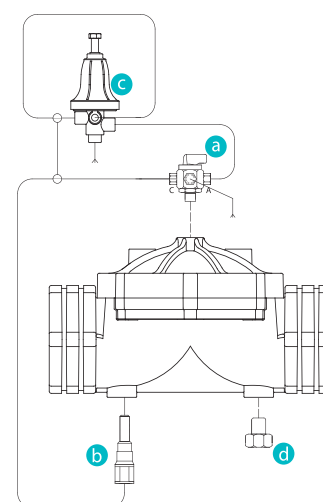

a 3W selector valve
b In-line finger filter
c Plastic Pilot
d Plug

* To order valves manufactured according to your specific requirements, please contact our technical sales department

b **BACCARA**[®]
AUTOMATION & CONTROL



CONTROLLERS & SPECIAL

VALVES

OCTOPUS™	Automatic Filter, Filter Backwash.....	76
ii.ri-C	Smart Irrigation Controller 2 Way.....	78
ii.ri-C-VSA	Smart Irrigation Controller 3 Way.....	80
GEM-FLOW™ G75-C	Irrigation Controller 1, 2 & 4 Valves.....	82
GEM-FLOW™ G75-C-1W & 1W+	Irrigation Window Controller.....	84
GEM-FLOW™ G75-DP	Baccara Differential Pressure Gauge Switch	86
GEM-FLOW™ G75-DFC-DC	Baccara Filtration Controller Set (DFC)	87
GEM-FLOW™ G75-BWM	Baccara Water Meter Controller.....	88
GEM-FLOW™ G75-DLS	Digital Level Switch	89
GEM-FLOW™ G75-ADP	Baccara Analog Differential Pressure Sensor.....	90
GEM-SOL® LD032 (GEM-LDO)	Long Distance Operator 2 Way, 3 Way NC, NO.....	91
GEM-SOL® LD0S32 (LDOS)	Long Distance Operating Solenoid.....	92
GEM-FLOW™ G75-LDO	Long Distance Operator 2 Way, 3 Way NC, NO.....	93





OCTOPUS™

Filter Backwash Controller

- Filtration backwash controller 1+3 or 1+10 stations
- Mobile app in various languages
- Wireless operated by smartphone
- Main valve output is included
- Backwash by DP, Time interval or Manual
- Upstream & Downstream pressure sensors



Technical Data

Communication protocol	Wireless BLE
App Downloading	 
Mechanical	<ul style="list-style-type: none"> • Operating temperature: -10°C to 60°C • Outdoor UV protection • "H" proof pressure: 10 bar (145 PSI) • "H" pressure must be ≥ "L" pressure
Electrical	<ul style="list-style-type: none"> • DC units are powered by 8 x C type alkaline batteries or 12V DC
Mounting	<ul style="list-style-type: none"> • Pressure ports 8mm • High pressure port is marked by the letter "H" on the housing • Wall mounting with four Ø3.5 plastic-screws or the two M5 (low profile) self-tapping screws
Features	<ul style="list-style-type: none"> • Differential pressure up to 10 bars • Time interval • Manual operation • Alarm and backwash output for communication with irrigation controller • Data logger
Options	<ul style="list-style-type: none"> • Mounting bracket measurements upon request
Standard protection class	<ul style="list-style-type: none"> • IP65 Dust and watertight
Solenoid	G75-A 12 OHM, G75-A3P-4 OHM, G75-P-12 OHM, GEM-A3P-IL 2 wires only

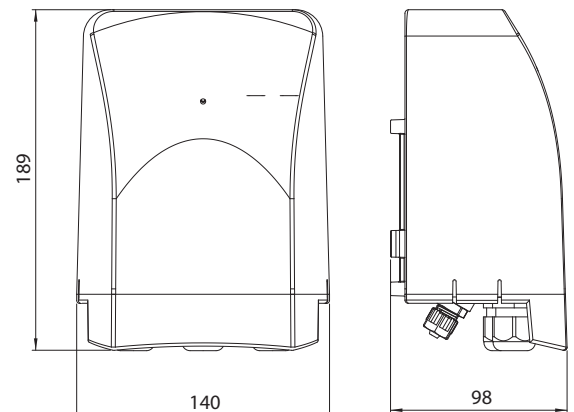
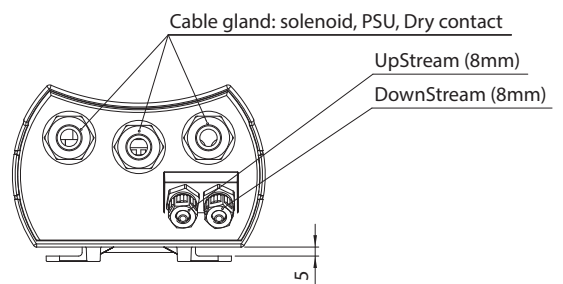

How to Order

G75-Octopus	-	TYPE	Example: G75-Octopus-10
		1+3 stations	03
		1+10 stations	10

Octopus™, 10 stations + 1 Main valve

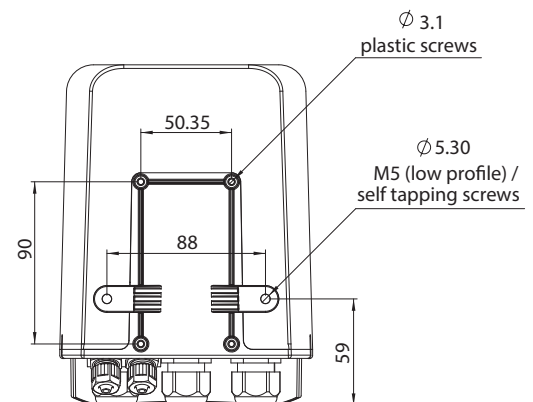

IOM OCTOPUS

* To order controllers manufactured according to your specific requirements, please contact our technical sales department

OCTOPUS™ | Filter Backwash Controller

The App

Available in 9 languages:

English | Arabic | French | German | Hebrew | Portuguese | Spanish | Turkish | Italian

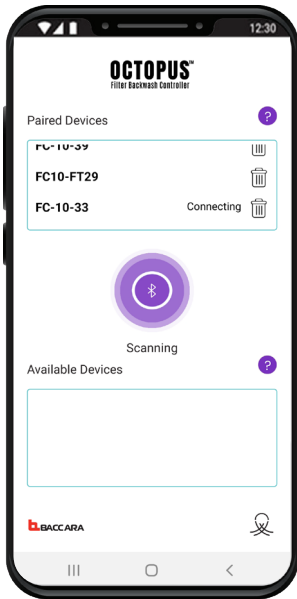

Device manager

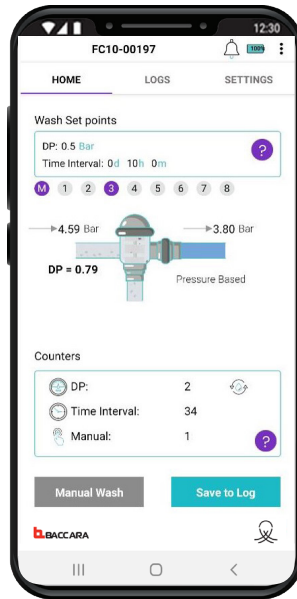

Home screen

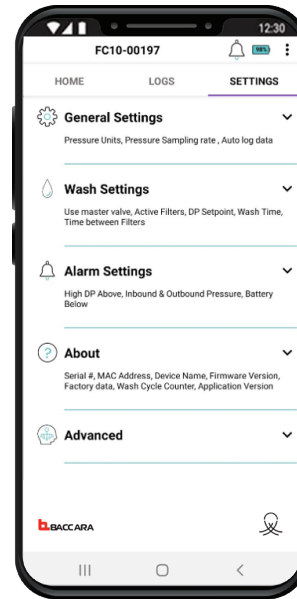

Settings

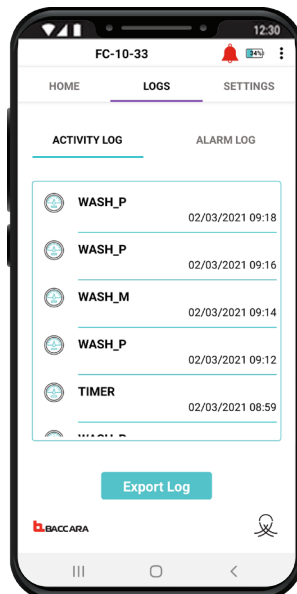

Activity log

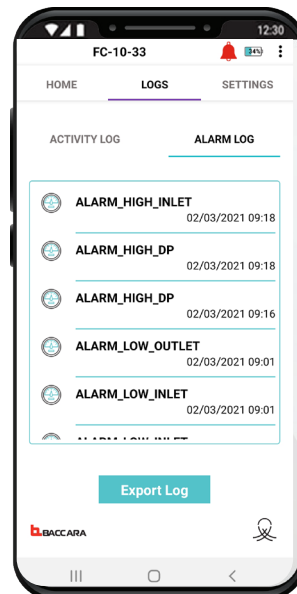

Alarm log

CONTROLLERS & SPECIAL VALVES



ii.ri-C

Smart Irrigation Controller 2 Way



- Single station Irrigation Controller
- Wireless operated by smart device
- Four irrigation program types
- Minimum required iOS 7 or Android V4.3
- Battery included

Technical Data

Function	2 Way Latch
Pressure range	0.5 to 8 bar
Temperature range	Fluid: 5° to 50°C (no freezing) Ambient: -5° to 50°C
Communication protocol	Wireless BLE
App Downloading	 
Pairing code	Not required
Communication range	Up to 10 m (32.8 feet)
Battery type	CR123
Mounting	Direct mounting on UNEF 3/4"
Standard / Certification	<ul style="list-style-type: none"> • CE • Federal Communications Commission (FCC) • EN55011 Group1 - Class A / EN61000-6-1/ CFR 47 FCC Class A • EMC- SII Certificate of Conformity
Standard protection class	• Dust and watertight IP68

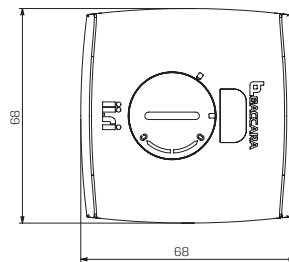
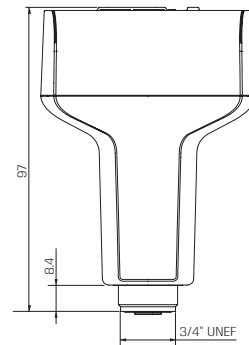

ii.ri-C | Smart Irrigation Controller 2 Way

Programming Key Features

Four different irrigation plans

Weekly	Interval Days	Even / Odd Days	Window
Irrigation each day of the week	Periodical days up to 98 periods	Even / odd calendar dates	Repeated cycles within a defined time frame
Set up to 6 cycles per day			Set cycle On and Off duration
Option to set different irrigation durations per cycle			Set start and end times for irrigation

How to Order

ii.ri-C	PORT	FLOW CONTROL	COLOR
	None Null	with 5	Grey CLOUD
	3/4" BSPT 50	without ⁽¹⁾ 6	
	3/4" NPT 51		
	1" BSPT 60		
	1" NPT 61		
	1-1/2" BSPT 70		
	1-1/2" NPT 71		
	2" BSPT 80		
	2" NPT 81		

Example: ii.ri-C-51-6-CLOUD

ii.ri Smart Irrigation Controller with 3/4" NPT valve, without flow control, color CLOUD

(1) For 3/4" and 1" valves only

* To order controllers manufactured according to your specific requirements, please contact our technical sales department

CONTROLLERS & SPECIAL VALVES



ii.ri-C-VSA

Smart Irrigation Controller 3 Way



- Single station Irrigation Controller
- Wireless operated by smart device
- Four irrigation program types
- Minimum required iOS 7 or Android V4.3
- Battery included

Technical Data

Function	3 Way Latch
Pressure range	0 to 8 bar
Temperature range	Fluid: 5° to 50°C (no freezing) Ambient: -5° to 50°C
Communication protocol	Wireless BLE
App Downloading	 
Pairing code	Not required
Communication range	Up to 10 m (32.8 feet)
Battery type	CR123
Mounting	Direct mounting on UNEF 3/4"
Standard / Certification	<ul style="list-style-type: none"> • CE • Federal Communications Commission (FCC) • EN55011 Group1 - Class A / EN61000-6-1/ CFR 47 FCC Class A EMC- SII Certificate of Conformity
Standard protection class	• Dust and watertight IP68

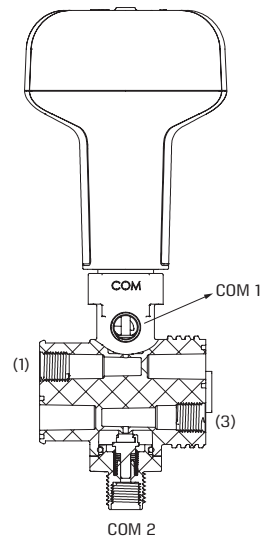

Programming Key Features

Four different irrigation plans

Weekly	Interval Days	Even / Odd Days	Window
Irrigation each day of the week	Periodical days up to 98 periods	Even / odd calendar dates	Repeated cycles within a defined time frame
Set up to 6 cycles per day			Set cycle On and Off duration
Option to set different irrigation durations per cycle			Set start and end times for irrigation

PORT	NO	NC
1	Exhaust	Pressure
3	Pressure	Exhaust
COM	Out	Out

ii.ri-C-VSA | Smart Irrigation Controller 3 Way

Dimensions

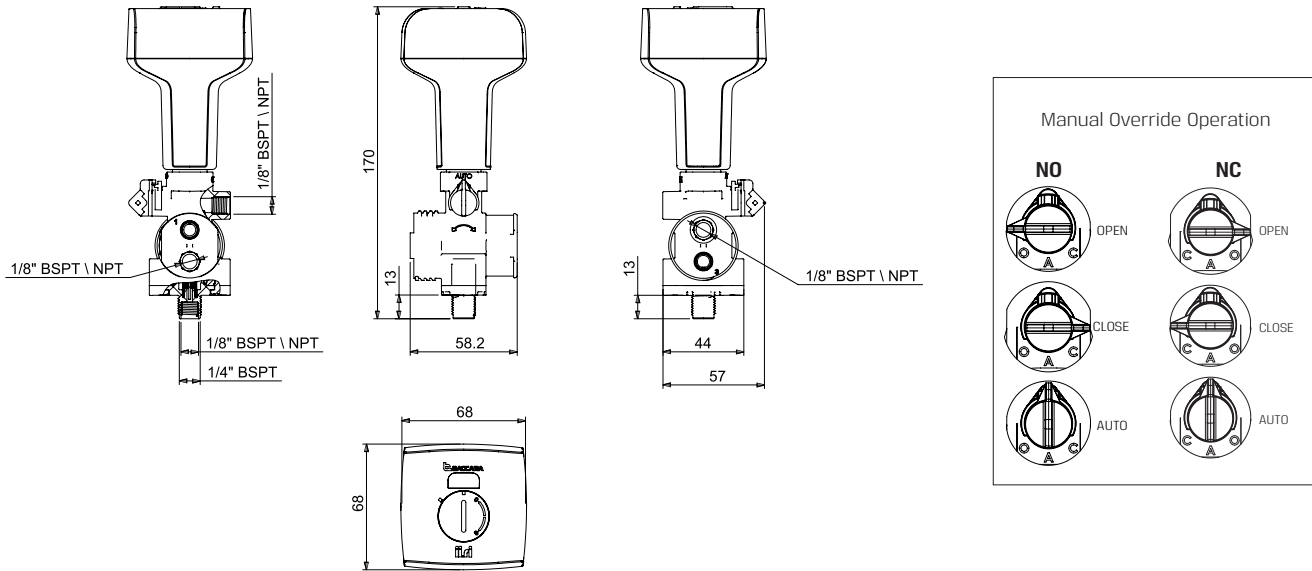

How to Order

ii.ri-C-VSA	BODY	PORT	FUNCTION	SEALS
	Plastic	4	1/8" BSP 10	3W NC 3 EPDM E
			1/8" NPT 11	3W NO 4

Example: ii.ri-C-VSA-4103E
 ii.ri smart irrigation controller with 1/8" BSP valve, 3W NC, EPDM seals

* To order controllers manufactured according to your specific requirements, please contact our technical sales department

CONTROLLERS & SPECIAL VALVES

GEM-FLOW™ | G75-C

Irrigation Controller | 1, 2 & 4 Valves



Technical Data

Operating temperature	-10° to 60°C
Mounting	<p>Various mounting options:</p> <ul style="list-style-type: none"> • Directly on a 28mm diameter solenoid in horizontal or vertical position with adaptor • Wall mounting with four screws • Accessories provided
Electrical	<p>Powered by single 9V alkaline battery; use best quality to ensure at least one year's autonomous operation.</p> <ul style="list-style-type: none"> • Back-up memory • Low battery warning • Power saving LCD • Battery included
Solenoid	Compatible with G75 4Ω latch operator
Valve	Can operate any valve equipped with 3/4" UNEF solenoid cavity (Richdel® type)
Software	<ul style="list-style-type: none"> • 24 hours real time clock • See 'Programming key features' table
Options	<ul style="list-style-type: none"> • Solar panel • Charger • Accurate clock (low time drift)
Standard / Certification	CE
Standard protection class	<ul style="list-style-type: none"> • Dust and watertight • IP67 and NEMA 4X



G75 One Valve

G75 Two Valves

G75 Four Valves

Size	A	B	C
3/4"	145	110	81
1"	153	110	81
1-1/2"	166	160	127
2"	166	170	127

Mounting Options

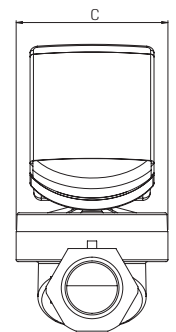
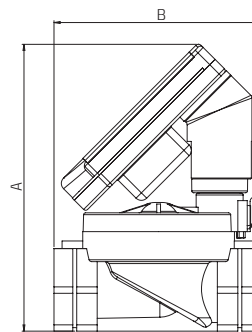

GEM-FLOW™ | G75-C | Irrigation Controller | 1, 2 & 4 Valves

Programming Key Features

One Valve	Two Valves	Four Valves
Once daily, at the same time	Up to three starts per day	Up to three starts per day
Once daily on selected days	Starts select	Starts select
Three starts per day	Day select	Day select
OFF	Season adjustment 10% - 200%	Season adjustment 10% - 200%
	OFF	OFF
		Master valve will be opened for each command

How to Order

G75-C	-	TYPE OF CONTROLLER ⁽¹⁾	-	VALVE 1 ⁽¹⁾	
		One valve	1	No valve	00
		Two valves	2	1/2" BSP	40
		Four valves	4	1/2" NPT	41
				3/4" BSP	50
				3/4" NPT	51
				1" BSP	60
				1" NPT	61
				1-1/2" BSP	70
				1-1/2" NPT	71
				2" BSP	80
				2" NPT	81
				G75-A *	

* G75-A

TYPE	PORT	FUNCTION	MANUAL OVERRIDE	ORIFICE
with flange	1/8" BSP	2W NC	None	1.0 ⁽²⁾
Brass	1/8" NPT	3W NC		1.2
	1/4" BSP ⁽²⁾	3W NO		1.6
	1/4" NPT ⁽²⁾			3

1) Example: G75-C-160

GEM-FLOW™ G75 One Valve controller, 1" BSP

(1) Only for One valve controller type. Choose "00" for Two and Four valve controller types

(2) Brass only

* To order controllers manufactured according to your specific requirements, please contact our technical sales department

CONTROLLERS & SPECIAL VALVES

GEM-FLOW™ | G75-C-1W & 1W+

Irrigation Window Controller



Technical Data

Operating temperature	-10° to 60°C
Mounting	<p>Various mounting options:</p> <ul style="list-style-type: none"> • Directly on a 28mm diameter solenoid in horizontal or vertical position with adaptor • Wall mounting with four screws • Accessories provided
Electrical	<p>Powered by single 9V alkaline battery; use best quality to ensure at least one year's autonomous operation.</p> <ul style="list-style-type: none"> • Back-up memory • Low battery warning • Power saving LCD • Battery included
Solenoid	<p>Both Window and Window+ controllers have identical programming.</p> <ul style="list-style-type: none"> • Window: compatible with G75 4Ω latch operator • Window+: has a stronger output to operate G80 latch and GEM-SOL® '1L' latch coils
Valve	<ul style="list-style-type: none"> • Window: can operate any valve equipped with 3/4" UNEF solenoid cavity (Richdel® type) • Window+: only with Baccara latch valve
Software	<ul style="list-style-type: none"> • 24 hours real time clock • See 'Programming key features' table
Options	<ul style="list-style-type: none"> • Solar panel • Charger • Accurate clock (low time drift)
Standard / Certification	CE
Standard protection class	<ul style="list-style-type: none"> • Dust and watertight • IP67 and NEMA 4X



G75 Window +



Irrigation cycles within a defined time frame

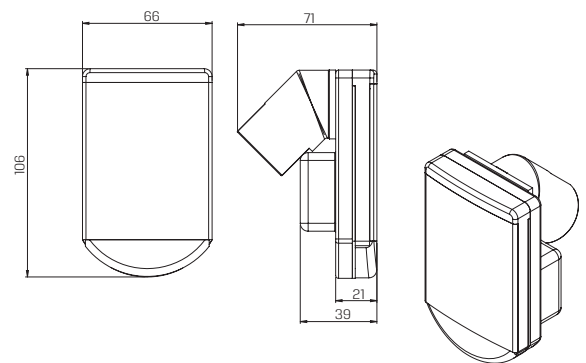

Mounting Options

Wall mounting



Horizontal mounting



GEM-FLOW™ | G75-C-1W & 1W+ | Irrigation Window Controller

Programming Key Features

Set start and end hours
Set On time (1 second to 12 hours)
Set Off time (1 min to 12 hours)
Day select
OFF

How to Order: G75 Window

G75-C-1W	-	VALVE
		No valve 00
		1/2" BSP 40
		1/2" NPT 41
		3/4" BSP 50
		3/4" NPT 51
		1" BSP 60
		1" NPT 61
		1-1/2" BSP 70
		1-1/2" NPT 71
		2" BSP 80
		2" NPT 81
		G75-A *

* G75-A

TYPE	PORT	FUNCTION	MANUAL OVERRIDE	ORIFICE
with flange 1	1/8" BSP 10	2W NC 1	None 0	1.0 ⁽¹⁾ 1
Brass 3	1/8" NPT 11	3W NC 3		1.2 2
	1/4" BSP ⁽¹⁾ 20	3W NO 4		1.6 3
	1/4" NPT ⁽¹⁾ 21			

* This controller will only operate with G75 operators

Example: G75-C-1W-50

GEM-FLOW™ G75 Window controller with 3/4" BSP valve.

(1) Brass only

How to Order: G75 Window+

G75-C-1W+	-	VALVE
		Refer to How to Order section of GEM-SOL® valves. Consult with us to discuss your specific requirements.

Example: G75-C-1W+-GEM-A-21045NO

GEM-FLOW™ G75 Window+ controller with: GEM-SOL® A32 (GEM-A) valve, Brass, 1/8" BSP, 3W NO, 2.4 orifice, NBR, no manual override.

* To order controllers manufactured according to your specific requirements, please contact our technical sales department

GEM-FLOW™ | G75-DP

Baccara Differential Pressure Gauge Switch

- Reads and reacts to pressure differential between two reading points
- Suitable to work with both media - air and liquid
- Main applications: filters backwash, pumps control, pressure control

Technical Data

Mechanical	<ul style="list-style-type: none"> • Operating temperature: -10°C to 60°C (no freezing) • Outdoor UV protection • Front panel cover protection • "H" proof pressure: 14 bar (203 PSI) • "H" pressure must be \geq "L" pressure.
Electrical	<ul style="list-style-type: none"> • Power supply: 6-24V DC or 12-24V AC • RED + BLK power supply • YELLOW / WHT N.O contact • Low power detect • Dry contact (N.O) 0.5A at 24V AC • Internal memory to retain "set-up data" at power down.
Mounting	<ul style="list-style-type: none"> • 2" (52mm) diameter • 2ft (60cm) 4 wires cable • Pressure ports 1/8" BSP/NPT (male) • High pressure port is marked by the letter "H" on the housing • Connect high pressure before low pressure • Disconnect low pressure before high pressure
Software	See 'Programming key features' table
Display	<p>The LCD display:</p> <ul style="list-style-type: none"> • DIF: measured differential pressure • SET: pressure differential trigger setting • ON: displayed when the switch contacts are closed <p>Display resolution:</p> <p>1 PSI in the range 0 - 99 psi 0.1 bar in the range 0.0 - 7 bar</p>
Standard protection class	<ul style="list-style-type: none"> • Dust and watertight • IP66

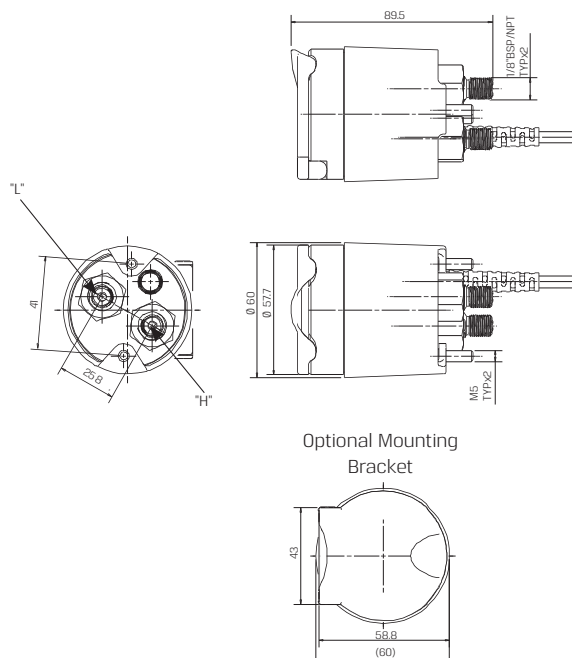

How to Order

G75-DP	-	TYPE	ACCESSORIES
		Stand alone	1
		Mounting bracket	B

Example: G75-DP-1B
GEM-FLOW™ G75-DP Baccara Differential Pressure Gauge switch, stand alone with mounting bracket

Programming Key Features

Manual operation
PSI or bar display
Time interval between pressure measurements
Contact closed time
Time interval between contact closure
Zero calibration

* To order special valves manufactured according to your specific requirements, please contact our technical sales department

GEM-FLOW™ | G75-DFC-DC

Baccara Filtration Controller Set (DFC)

- Filtration backwash controller 1-3 stations
- Main valve output is optional
- Backwash by DP or time interval
- The assembly includes controller and differential pressure sensor
- Mounting bracket optional



Technical Data

Controller Set Supplied with	DFC controller, suitable for DC only, and one analog sensor
Mechanical	<ul style="list-style-type: none"> • Operating temperature: -10°C to 60°C • Outdoor UV protection • Front panel cover protection • "H" proof pressure: 14 bar (203 PSI) • "H" pressure must be ≥ "L" pressure.
Electrical	<p>DC units are powered by single 9V alkaline battery; use best quality to ensure at least one year's autonomous operation.</p> <ul style="list-style-type: none"> • Back-up memory • Low battery warning • Power saving LCD
Mounting	<ul style="list-style-type: none"> • Pressure ports 1/8" BSP/NPT (male) • High pressure port is marked by the letter "H" on the housing • Connect high pressure before low pressure • Disconnect low pressure before high pressure <p>Controller:</p> <ul style="list-style-type: none"> • Directly on a 28mm diameter solenoid in horizontal or vertical position with adaptor • Wall mounting with four screws • Accessories provided Sensor: 2" (52 mm diameter)
Software	See 'Programming key features' table
Options	Option to change default factory settings
Standard protection class	• IP66 Dust and watertight
Solenoid	G75-A, GALIT Latch 4Ω, G75-A3P 1Ω

Programming Key Features

Manual operation
Valve ON time
Maximum time interval between washes
Valve selection

How to Order

G75-DFC-DC	-	TYPE	-	MOUNTING BRACKET
		3 Valves	0	without 0
		3 Valves + 1 Main Valve	1	with 1

Example: G75-DFC-DC-1-1

GEM-FLOW™ G75-DFC-DC, 3 Valves + 1 Main valve, with mounting bracket

* To order controllers manufactured according to your specific requirements, please contact our technical sales department

CONTROLLERS & SPECIAL VALVES

GEM-FLOW™ | G75-BWM

Baccara Water Meter Controller

- Single station water volume controller
- Connected to a water meter with pulse outlet
- Opens at a set time and closes when required water volume has been reached

Technical Data

Operating temperature	-10° to 60°C
Electrical	Powered by single 9V alkaline battery; use best quality to ensure at least one year's autonomous operation. <ul style="list-style-type: none"> • Back-up memory • Low battery warning • Power saving LCD • Battery included
Mounting	Various mounting options: <ul style="list-style-type: none"> • Directly on a 28mm diameter solenoid in horizontal or vertical position with adaptor • Wall mounting with four screws • Accessories provided
Solenoid	Compatible with G75 4Ω latch operator
Measurement units per pulse	100 liters 1m³ 10m³ 100 gallons 1000 gallons
Software	<ul style="list-style-type: none"> • 24 hours real time clock • See 'Programming key features' table
Options	Solar panel, charger
Standard protection class	<ul style="list-style-type: none"> • Dust and watertight • IP67 and NEMA 4X

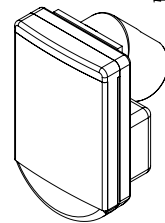
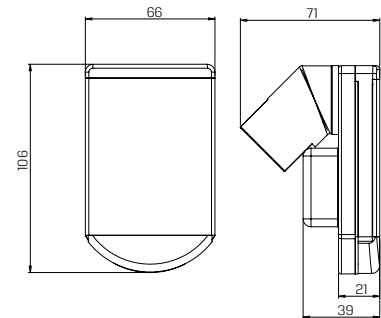

How to Order

G75-BWM		VALVE		* G75-A															
				TYPE	PORT	FUNCTION	MANUAL OVERRIDE	ORIFICE											
	No valve		00	with flange	1	1/8" BSP	10	2W NC	1	None	0	1.0 (1)	1						
	1/2" BSP		40	Brass	3	1/8" NPT	11	3W NC	3			1.2	2						
	1/2" NPT		41																
	3/4" BSP		50											1/4" BSP (1)	20	3W NO	4	1.6	3
	3/4" NPT		51											1/4" NPT (1)	21				
	1" BSP		60																
	1" NPT		61																
	1-1/2" BSP		70																
	1-1/2" NPT		71																
	2" BSP		80																
	2" NPT		81																
	G75-A *																		

Programming Key Features

Set start time
Set required water volume
Day select
OFF

Example: G75-BWM-G75-A-110102

GEM-FLOW™ G75-BWM - G75-A with flange, 1/8" BSP, 2W NC, no manual override, 1.2 orifice

(1) Brass only

* To order controllers manufactured according to your specific requirements, please contact our technical sales department

GEM-FLOW™ | G75-DLS

Digital Level Switch

- Measuring level of two set points: top and bottom
- Gives a signal to pump or valve
- Dry installation - no elements inside the tank
- Main applications: filling or draining of water reservoir and tanks

Technical Data

Mechanical	<ul style="list-style-type: none"> • Operating temperature: -10°C to 60°C (no freezing) • Outdoor UV protection • Front panel cover protection
Electrical	<ul style="list-style-type: none"> • Power supply: 6-24V DC or 12-24V AC • RED + BLK power supply • GRN / WHT N.O contact • Low power detect • Dry contact (N.O) 0.5A at 24V AC • Internal memory to retain "set-up data" at power down.
Mounting	<ul style="list-style-type: none"> • 2" (52mm) diameter • 2ft (60cm) 4 wires cable • Pressure ports 1/8" BSP/NPT (male) • High pressure port is marked by the letter "H" on the housing • Connect the water tank to the "H" port only
Software	See 'Programming key features' table
Display	<ul style="list-style-type: none"> • The LCD display shows the water level above the DLS mounting place • "ON" is displayed when the switch contacts are closed <p>Display resolution:</p> <ul style="list-style-type: none"> • 10 cm in a range of 0.0 - 70.0m • 0.01 bar in the range 0.0 - 7 bar
Standard protection class	<ul style="list-style-type: none"> • Dust and watertight • IP66

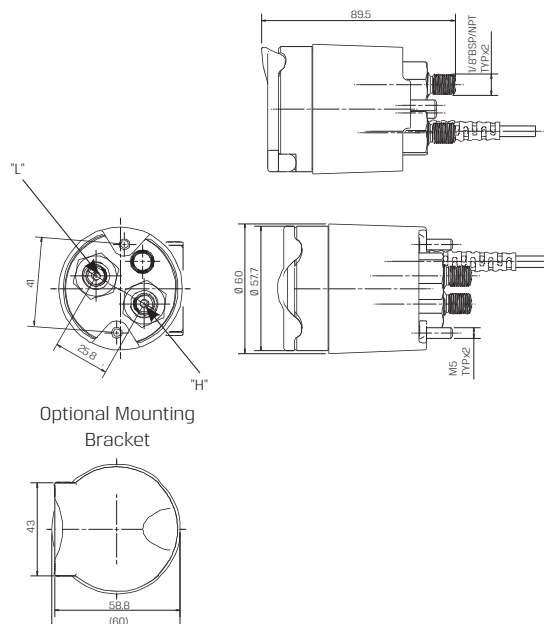

How to Order

G75-DLS	-	TYPE	ACCESSORIES
		Stand alone	1 Mounting bracket B

Programming Key Features

Manual operation
Time interval between level measurements function
Function: "SET" for fill "RESET" for empty
Zero calibration

Example: G75-DLS-1B

GEM-FLOW™ G75-DLS Digital Level switch, stand alone, with mounting bracket

* To order special valves manufactured according to your specific requirements, please contact our technical sales department

GEM-FLOW™ | G75-ADP

Baccara Analog Differential Pressure Sensor

- Differential pressure to current transducer
- Suitable to work with both media - air and liquid
- Main application: analog sensor for filters backwash

Technical Data

Mechanical	<ul style="list-style-type: none"> • Operating temperature: -10°C to 60°C (no freezing) • Outdoor UV protection • Measuring pressure range: 0-7 bar (0-101.5 PSI) • "H" proof pressure: 14 bar (203 PSI) • "H" pressure must be \geq "L" pressure
Electrical	<ul style="list-style-type: none"> • Power supply: 5V DC • RED: (+) 5V • BLACK: (-) 5V • ORANGE: analog output • Analog output value: 0.2V to 4.7V, [V out = (0.006429xKpa+0.2)± Error] • Output accuracy: 2.5% of full scale
Mounting	<ul style="list-style-type: none"> • 2" (52mm) diameter • 2ft (60cm) 3 wires cable • Pressure ports 1/8" BSP/NPT (male) • High pressure port is marked by the letter "H" on the housing • Connect high pressure before low pressure • Disconnect low pressure before high pressure
Standard protection class	<ul style="list-style-type: none"> • IP66

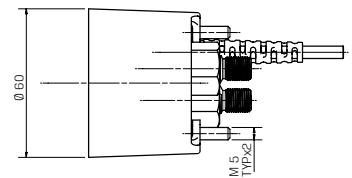
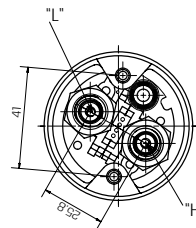
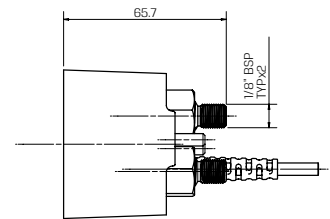

Optional Mounting Bracket

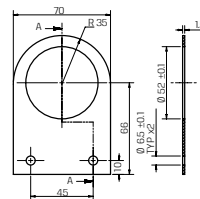

How to Order

G75-ADP	-	TYPE	MOUNTING BRACKET	
		Stand alone	1	without 0 with 1

Example: G75-ADP-10

GEM-FLOW™ G75-ADP Baccara Analog Differential Pressure sensor, stand alone, without mounting bracket

* To order controllers manufactured according to your specific requirements, please contact our technical sales department

GEM-SOL® | LD032 (GEM-LDO)

Long Distance Operator 2 Way, 3 Way NC, NO

Technical Data

Function	2 Way, 3 Way NC, NO
Current	Holding 4mA
Pressure range	Refer to working pressure definitions of the valve that the GEM-LDO is assembled on, with DC10W/AC8W
Power	<ul style="list-style-type: none"> • DC12V (0.05W) up to DC24V (0.1W) • 24V AC: 0.3W
Connection	Red/Black - power supply Green/Black - coil Lead wire length - 28cm PVC coated AWG 18 UL 1007
Ambient temp	-10°C to 70°C
Operation	Only with GEM-BL-LDO coil and Baccara valve
Applications	<ul style="list-style-type: none"> • Cost saving wiring for remote solenoid operation • Power saving and heat prevention on continuous energized solenoid
Voltage	Voltage and power consumption - see table
Standard protection class	IP67 (LDO only)

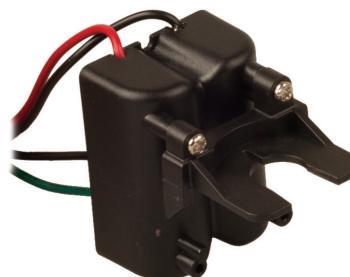

LDO unit

A small section conductor can be used at a distance of up to 5 kms

* For recommended wire parameters, please refer to Long distance operators charts

Voltage	Distance (km)	Conduit section (mm ²)	Delay Time (sec)	
			On	Off
12/24	5	0.5	3	1

* Max conduit resistance 390 at nominal voltage

Voltage & Power Consumption

	AC (W)		DC(W)	
	50 Hz	60 Hz	0.05	0.1
V	0.3	0.3	•	•
12				
24	•	•		

• Available options

How to Order

GEM-LDO	-	VOLTAGE	-	Please refer to the "How to Order" definitions of the assembled GEM-SOL® valve.
		24 VAC & 12-24 VDC	9	

Example: GEM-LDO-9-GEM-A-21035NO

GEM-SOL® LD032 (GEM-LDO) is attached to a GEM-SOL® latch coil, direct operated, Brass 1/8" BSP, 3W NC, 2.4 orifice, NBR, no manual override

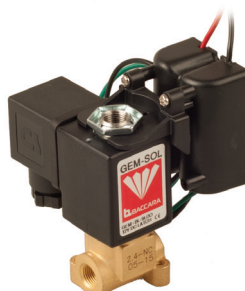

Assembled with A32(GEM-A) solenoid

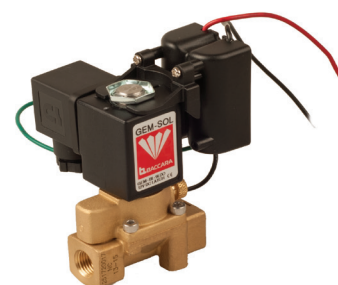

Assembled with S32(GEM-S) solenoid

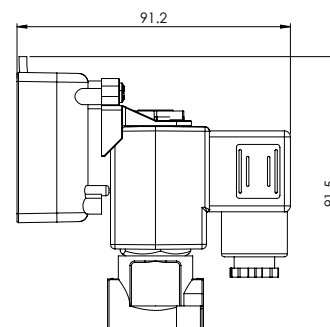
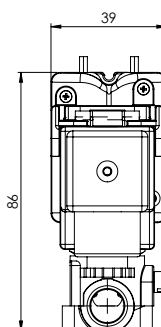

* To order special valves manufactured according to your specific requirements, please contact our technical sales department

CONTROLLERS & SPECIAL VALVES

GEM-SOL® | LDOS32 (LDOS)

Long Distance Operating Solenoid

Technical Data

Current	24V AC: Inrush 210mA Holding 18mA 12V DC: Inrush 120mA Holding 5mA
Pressure range	See table
Delay time	See table
Connection	DIN 43650 Connecting box
Ambient temp	-10°C to 70°C
Operation	Only with a Baccara valve
Applications	<ul style="list-style-type: none"> • Cost saving wiring for remote solenoid operation • Power saving and heat prevention on continuous energized solenoid
Voltage	<ul style="list-style-type: none"> • Voltage and power consumption - see table • +10% -10% of nominal
Standard protection class	IP65 with connector

* For recommended wire parameters, please refer to Long distance operators charts



LDOS unit
A small section conductor can be used at a distance of up to 5 kms.

Pressure (bar)

Function	Orifice (mm)	Pressure
3 Way NC	1.6	16
	2.0	10
	2.4	8
3 Way NO	1.6	16
	2.0	12
	2.4	8

Delay time (sec) at a nominal voltage	Distance (Km)	Conduit Section (mm)
4-5	2.4	0.5
	4.8	1.0
	7.5	1.5



Assembled with S32 (GEM-S) solenoid



Assembled with A32 (GEM-A) solenoid

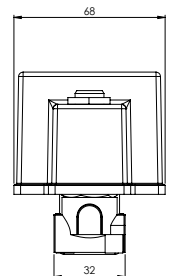
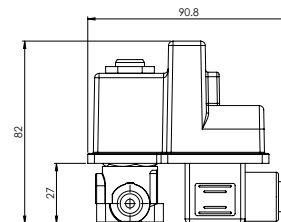
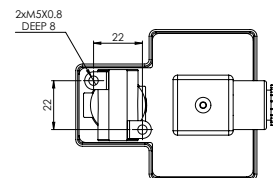

Voltage & Power Consumption

V	AC (W)		DC (W)
	50 Hz	60 Hz	
12			•
24	•	•	

• Available options

How to Order

LDOS	-	VOLTAGE	-	Please refer to the "How to Order" definitions of the assembled GEM-SOL® valve
		24V AC	1	
		12V DC	2	

Example: LDOS-1-GEM-A-21035NO

GEM-SOL® LDOS32 (LDOS) 24V AC is attached to a GEM-SOL® latch coil direct operated, Brass, 1/8" BSP, 3W NC, 2.4 orifice, NBR, no manual override

* To order special valves manufactured according to your specific requirements, please contact our technical sales department

GEM-FLOW™ | G75-LDO

Long Distance Operator 2 Way, 3 Way NC, NO

Technical Data

Function	2 Way, 3 Way NC, NO
Current	Holding 4mA
Pressure range	Refer to G75 Latch operator
Power	DC12V (0.05W) up to DC24V (0.1W)
Connection	Red/Black - power supply Green/Black - coil
Ambient temp	-10°C to 60°C
Solenoid	Compatible with G75 4Ω latch operator
Valve	Can operate any valve equipped with 3/4" UNEF solenoid cavity (Richdel® type).
Applications	<ul style="list-style-type: none"> • Cost saving wiring for remote solenoid operation • Power saving and heat prevention on continuous energized solenoid
Voltage	Voltage and power consumption - see table
Standard protection class	IP67 (LDO only)



LDO unit assembled with G75-A operator and solenoid
A small section conductor can be used at a distance of up to 5 kms

* For recommended wire parameters, please refer to Long distance operators charts

Voltage	Distance (km)	Conduit section (mm ²)	Delay time (sec)	
			On	Off
12/24	5	0.5	3	1

* Max conduit resistance 390 at nominal voltage

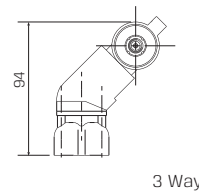
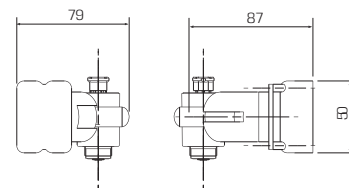
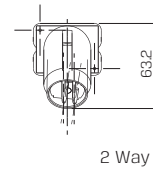
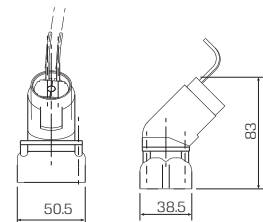

How to Order

G75-LDO	-	VOLTAGE	-	Please refer to the "How to Order" definitions of the assembled G75 valve.
		24 VAC & 12-24 VDC	9	

Example: G75-LDO-9-G75-A-11032B-1

GEM-FLOW™ G75-LDO 24V AC is attached to a G75-A with flange, 1/8" BSP, 3W NC 1.2 orifice, no manual override, 4Ω latch coil, two wires

* To order special valves manufactured according to your specific requirements, please contact our technical sales department

b **BACCARA**[®]
AUTOMATION & CONTROL



OPERATORS & COILS

GEM-SOL® GEM-B	Coil.....	96
GEM-SOL® GEM-BL	Latch Coil.....	98
GEM-SOL® GEM-BP	IP68 Coil.....	100
GEM-FLOW™ G75-0	AC/DC Operator 2 Way, 3 Way NC, NO.....	102
GEM-FLOW™ G75-0	Latch Operator 2 Way, 3 Way NC, NO.....	104



GEM-SOL® | GEM-B



Coil

Technical Data

Coil winding insulation	H 180°C
Temperature range	Coil: -20°C to 150°C Ambient: -20°C to 70°C
Duty cycle *	100% ED
Electrical connection	<ul style="list-style-type: none"> • AMP pins, DIN 46242, 2 poles + 1 earth • 2 flying leads, 18 AWG (0.75mm²), 330 mm length
Connector	<ul style="list-style-type: none"> • DIN 43650 • PG9 or 1/2" NPT * Max. tightening torque for the connector screw: 0.5 Nm
Assembly	In any position
Coil fixing	One nut G1/4" hexagonal 19mm
Impregnation	Optional
Coil voltage	<ul style="list-style-type: none"> • Voltage and power consumption - see table • All Baccara coil voltages are ±10% of nominal
Standard / Certification	CE
Standard protection class	IP65 with connector * Option: IP68 (please refer to GEM-BP coil)

- The coil should not be energized without being assembled on the operator
- * Please consult with our technical sales department:
 - for further information on using different power coils (not shown in the table)
 - for long term operation



DIN Connector

Flying Leads



LED Connector

Power Consumption (AC)

Type	Inrush	Holding	Cos Ø
8W	1800 [mA]	680 [mA]	0.46
5.5W	1700 [mA]	580 [mA]	0.51
2.5W *	300 [mA]	190 [mA]	0.54

* + 2 Diodes

Power Consumption (DC)

Type
10W
5.5W
2.5W

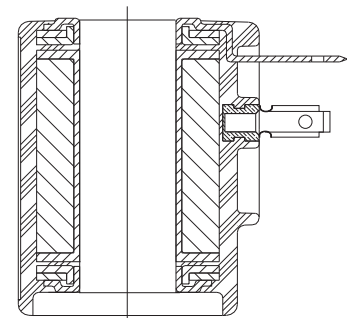

Voltage & Power Consumption

V	AC (W)						DC (W)		
	50 Hz			60 Hz			10	5.5	3.5
6							•	•	•
12	•			•			•	•	•
24	•	•	•	•	•	•	•	•	•
48	•			•			•		
110	•			•	•		•		
120	•			•	•				
220	•	•	•	•			•		
230	•	•		•	•				
240	•			•			•		

- Available options

GEM-SOL® | GEM-B | Coil

Dimensions

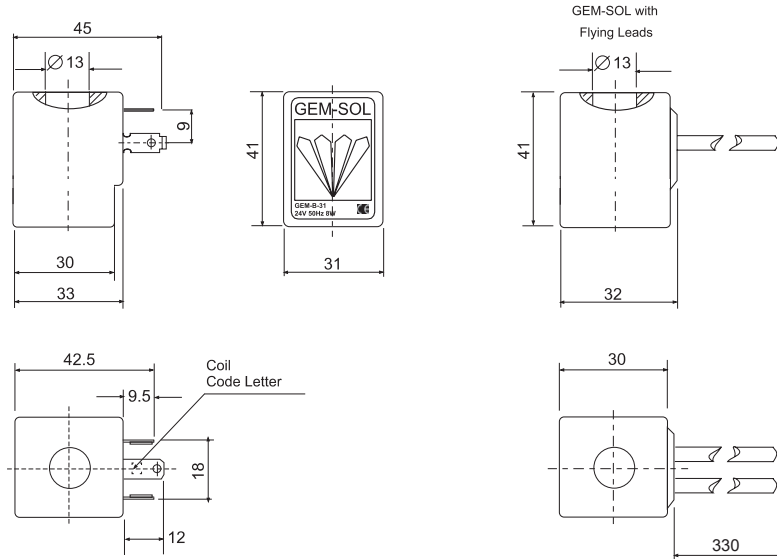

How to Order

GEM-B	-	VOLTAGE	POWER	CONNECTOR
6 ⁽¹⁾	1	AC8W 50Hz	1	with 1
12	2	AC8W 60Hz	2	with LED 2
24	3	DC10W	3	flying leads coil * 4
48	4	AC5.5W 50Hz	4	with 1/2" hub 5
110	5	AC5.5W 60Hz	5	surge protection with LED * 6
120	6	AC2.5W 50/60Hz	6	connector with moulded cable 7
220	7A	DC5.5W	7	other 9
230	7	DC3.5W	8	
240	8			
	Latch/other* ⁽²⁾		9	

* **SPECIAL OPTIONS** | Extended lead times, Non-stock items, MOQ may be applicable

Example: GEM-B-341

GEM-SOL® GEM-B Coil 24V AC 5.5W 50Hz with connector

(1) DC only

(2) For specifying Latch type coil, please refer to A3P32 (GEM-A3P) valve - How to Order table

* To order coils manufactured according to your specific requirements, please contact our technical sales department

GEM-SOL® | GEM-BL



Latch coil

Technical Data

Coil winding insulation	H 180°C
Temperature range	Coil: -20°C to 150°C Ambient: -20°C to 70°C
Electrical connection	<ul style="list-style-type: none"> • AMP pins, DIN 46242, 2 poles + 1 earth • 2 flying leads, 18 AWG (0.75mm²), 330 mm length
Connector	<ul style="list-style-type: none"> • DIN 43650 • PG9 or 1/2" NPT * Max. tightening torque for the connector screw: 0.5 Nm
Assembly	In any position
Coil fixing	One nut G1/4" hexagonal 19mm
Typical pulse time	30-50ms
Impregnation	Optional
Standard / Certification	CE
Standard protection class	IP65 with connector * Option: IP68 (please refer to GEM-BP coil)

- The coil should not be energized without being assembled on the operator
- The coil, including its magnetic circuit and permanent magnets, is encapsulated in high temperature resistant nylon to withstand humidity and meet heavy duty requirements.



When ordering for a new application, please inform us of your requirements according to the table below. This will enable us to determine the most suitable coil.

VOLTAGE	OPERATING METHOD	MAX CURRENT [A] ON COIL	CAPACITOR [µF]	SWITCHING TIME [ms]
3	Direct	≤2	None	≤25
6	Capacitor	≤1	2200	≤50
9		≤0.5	4700	≤100
12		≤0.1	other	other
24		other		
230				
Other				

Example: 12V DC, Capacitor, ≤1, 4700, ≤50ms

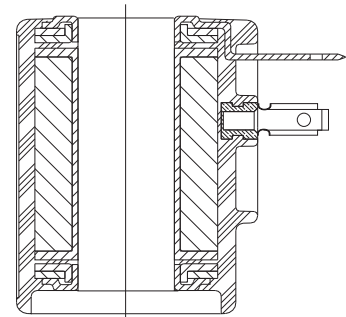

GEM-SOL® | GEM-BL | Latch coil

Dimensions

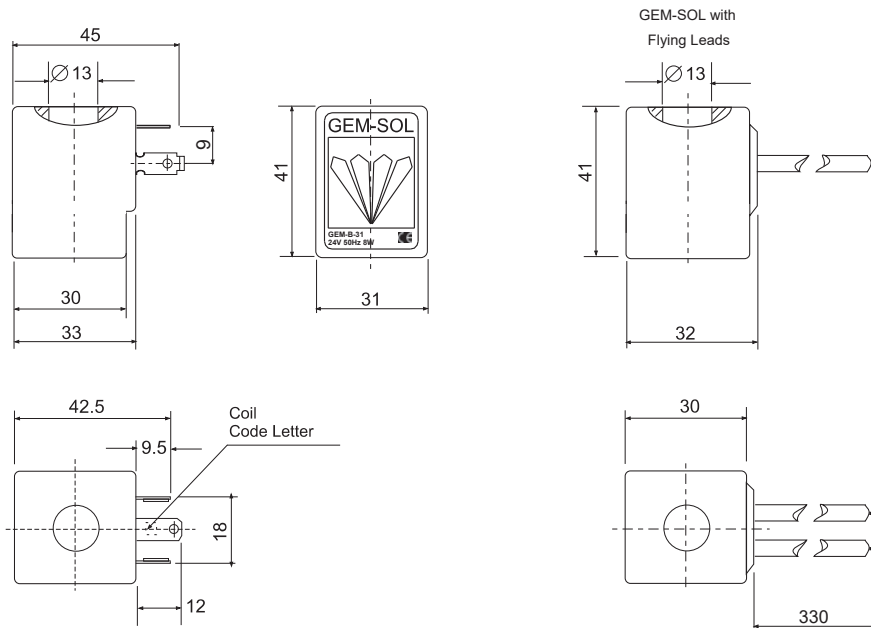

Operation Voltage

LATCH TYPE	Ω	Voltage
LDO	2	6 - 10.5
IL	5	9 - 14
EL	13	14.5 - 20
OL	20	18 - 29
DL	53	30 - 48

How to Order

GEM-BL	-	LATCH TYPE ⁽¹⁾	CONNECTOR
2 Ω	LDO	without	0
5 Ω	IL	with	1
13 Ω	EL	flying leads coil	4
20 Ω	OL	with 1/2" Hub	5
53 Ω	DL	connector with moulded cable	7
		other	9

Example: GEM-BL-LD01

GEM-SOL® GEM-BL Latch coil, 2 Ω latch with connector

(1) Choose latch type according to which latch system you have

* To order coils manufactured according to your specific requirements, please contact our technical sales department

GEM-SOL® | GEM-BP

IP68 Coil

Technical Data

Construction	Housing: encapsulated polyurethane
Coil winding insulation	H 180°C
Temperature range	Ambient: -5°C to 50°C (no icing)
Duty cycle	100% ED
Protection	IP68 infinite time immersion under water, up to 2m depth
Electrical connection	3x18 AWG (0.75mm ²), hook up wire, 200cm * other lengths are available
Assembly	In any position
Coil fixing	One nut G1/4" hexagonal 19mm
Standard / Certification	European Standards IEC 60529 code IP68
Coil voltage	<ul style="list-style-type: none"> • Voltage and power consumption - see table • All Baccara coil voltages are ±10% of nominal

- The coil should not be energized without being assembled on the operator

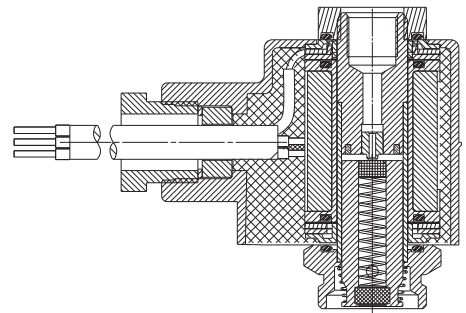

Power Consumption (AC)

Type	Inrush	Holding	Cos Ø
8W	1800 [mA]	680 [mA]	0.46
5.5W	1700 [mA]	580 [mA]	0.51
2.5W *	300 [mA]	190 [mA]	0.54

- * + 2 Diodes

Power Consumption (DC)

Type
10W
5.5W
3.5W

Voltage & Power Consumption

V	AC (W)						DC (W)		
	50 Hz			60 Hz			10	5.5	3.5
6									
12	•			•			•	•	•
24	•	•	•	•	•	•	•	•	•
48									
110									
120									
220									
230									
240									

- Available options

GEM-SOL® | GEM-BP | IP68 coil

Dimensions

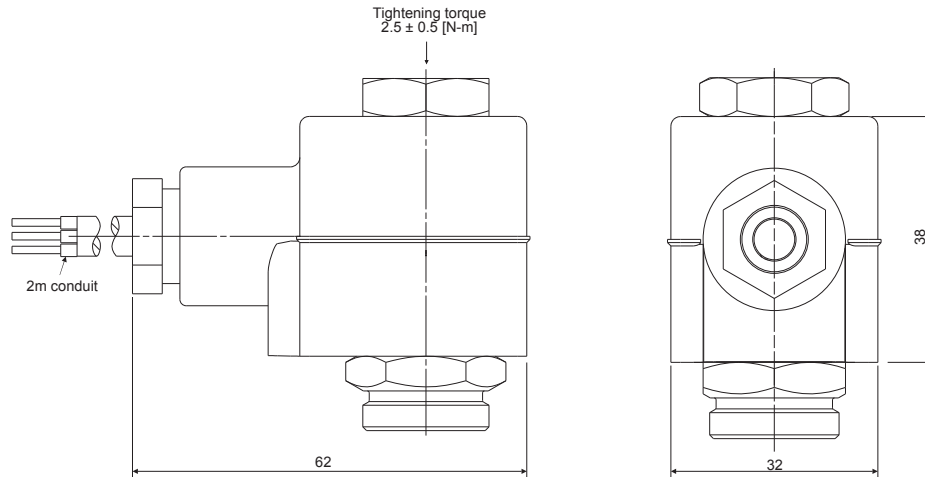

How to Order

GEM-BP	VOLTAGE	POWER ⁽¹⁾
12	2	AC8W 50Hz 1
24	3	AC8W 60Hz 2
		DC10W 3
		AC5.5W 50Hz 4
		AC5.5W 60Hz 5
		AC2.5W 50/60Hz 6
		DC5.5W 7
		DC3.5W 8
		2Ω LDO
		5Ω IL
		13Ω EL
		20Ω OL
		53Ω DL

Example: GEM-BP-31
GEM-SOL® GEM-BP IP68 Coil 24V AC 8W 50Hz.

(1) For Latch : choose type according to which latch system you have

* To order coils manufactured according to your specific requirements, please contact our technical sales department

OPERATORS & COILS

GEM-FLOW™ | G75-O

AC/DC Operator 2 Way, 3 Way NC, NO

Applicable for G75-A, Galit, G75-S & G75-Z valves

Technical Data

Function	2 Way, 3 Way NC, NO
Orifice size	2 Way: No orifice 3 Way: See table
Pressure range (bars)	See solenoid valve performances
Temperature range	Fluid: 5°C to 50°C (no freezing) Ambient: -10°C to 50°C
Materials in contact with media	Housing: Plastic (Reinforced Nylon 66) Plunger & pole: Stainless Steel AISI 430F Rubber Seals: EPDM Encapsulate: Polyurethane Spring: Stainless Steel AISI 300 series
Media	Air, water, oil *
Threads on operator tube	G1/8" or 1/8" NPT female to connect exhaust, muffler etc
Operator assembly	By manually screwing 3/4" UNEF to valve body. • Max. tightening torque: 2 N/m
Electrical connection	Lead wires 35 cm, 18 AWG (0.75mm ²) * other lengths are available
Coil voltage	• Voltage and power consumption - see table
Standard protection class	IP66

* For other fluids and for use in abnormal conditions, please contact our technical sales department

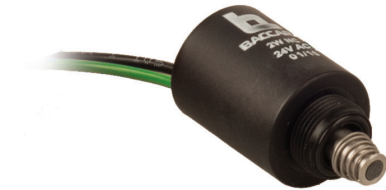

2 Way Operator

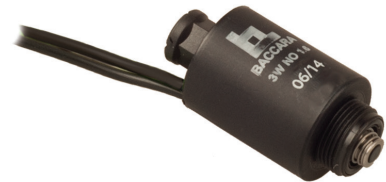

3 Way Operator

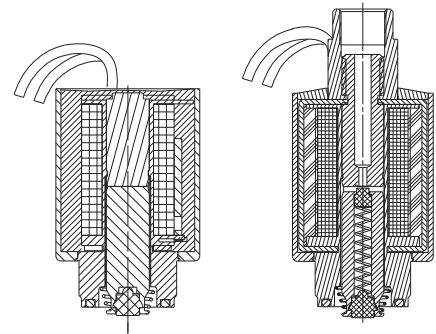

2 Way NC

3 Way NC / 3 Way NO

Working Pressure (bar) 2 Way NC

Orifice (mm)	up to 2.0
Pressure (bar)	12

Working Pressure (bar) 3 Way NC

Orifice (mm)	1.0	1.2	1.6
AC Pressure (bar)	16	11	6
DC Pressure (bar)	12	9	5

Working Pressure (bar) 3 Way NO

Orifice (mm)	1.0	1.2	1.6
Pressure (bar)	16	12	10

Voltage & Current

AC & DC

Solenoid	Voltage	Inrush [A]	Holding [A]
2 Way 50 Hz	V	0.3	0.19
2 Way 60 Hz		0.2	0.14
3 Way 50/60 Hz *		0.125	0.125
DC		4.5W	

* Except 24V AC without Diode

Voltage & Power Consumption

V	AC (W)	DC (W)
24	2	4.5
12	•	•
24	•	•
110	•	
	2 Way only	

• Available options

GEM-FLOW™ | G75-O | AC/DC Operator 2 Way, 3 Way NC, NO

Dimensions

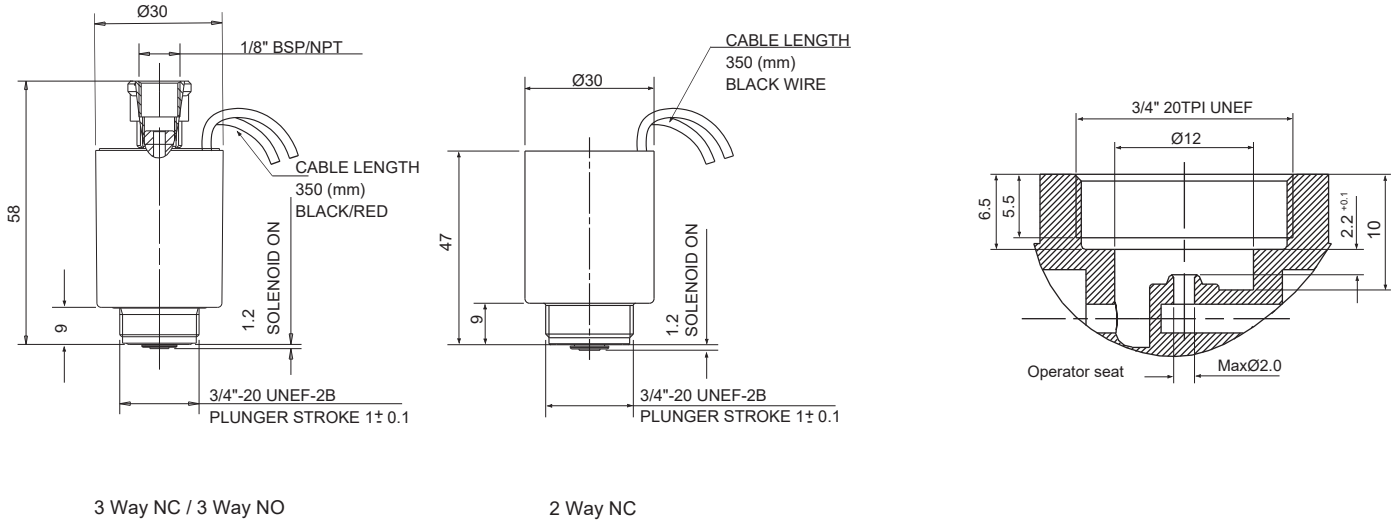

How to Order

2 Way

G75-0	FUNCTION	VOLTAGE
2W NC	1	24V AC 1
		24V AC w/out Diode ⁽¹⁾ 1R
		12V AC 3
		12V DC 4
		24V DC 5
		110V AC 7

G75-0	PORT	FUNCTION	ORIFICE
1/8" BSP	10	3W NC	3 1.0 1
1/8" NPT	11	3W NO	4 1.2 2
			3 1.6 3

Example: G75-0-1-1
GEM-FLOW™ G75 Operator, 2W NC, 24V AC

Example: G75-0-1032-1
GEM-FLOW™ G75 Operator, 1/8" BSP, 3W NC, 1.2 orifice, 24V AC

(1) 3W NO 1.6 mm: Max pressure is 8 bar

* To order operators manufactured according to your specific requirements, please contact our technical sales department

OPERATORS & COILS

GEM-FLOW™ | G75-0

Latch Operator 2 Way, 3 Way NC, NO

Applicable for G75-A, Galit, G75-S & G75-Z valves

Technical Data

Function	2 Way, 3 Way NC, NO Latch
Orifice size	2 Way: No orifice 3 Way: See table
Pressure range (bars)	See solenoid valve performances
Capacitors	• 4700µF for 9V DC • 2200µF for 12V DC
Switching time	25-50 ms
Temperature range	Fluid: 5°C to 50°C (no freezing) Ambient: -10°C to 50°C
Materials in contact with media	Housing: Plastic (Reinforced Nylon 66) Plunger & pole: Stainless Steel AISI 430F Rubber Seals: EPDM Encapsulate: Polyurethane Spring: Stainless Steel AISI 300 series
Threads on operator tube	G1/8" or 1/8" NPT female to connect exhaust, muffler etc
Two wire operator	One coil with exit of 2 lead wires. To pull the plunger up, connect the black wire (-) and the green to the (+).
Three wire operator	One coil and an integrated electrical circuit. To pull plunger up, pulse is given to the red wire (-). To release the plunger, pulse is given to the black wire (-). Operate only by a controller.
Electrical connection	• Lead wires 35 cm, 18 AWG (0.75mm ²) (black/green) • Lead wires: red, white, black for 3 wires
Voltage	9, 12V DC (coils for other voltages available)
Standard protection class	IP66

* Available with brass adaptor

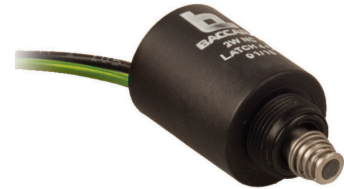

2 Way Operator



3 Way Operator

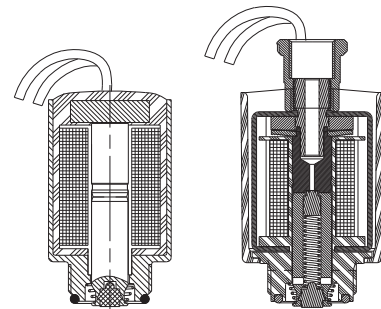

2 Way NC

3 Way NC / 3 Way NO

Working Pressure (bar) 2 Way NC

Orifice (mm)	up to 2.0
Pressure (bar)	12

Working Pressure (bar) 3 Way NC

Orifice (mm)	1.0	1.2	1.6
AC Pressure (bar)	16	11	6

Working Pressure (bar) 3 Way NO

Orifice (mm)	1.0	1.2	1.6
Pressure (bar)	16	12	10

GEM-FLOW™ | G75-O | Latch Operator 2 Way, 3 Way NC, NO

Dimensions

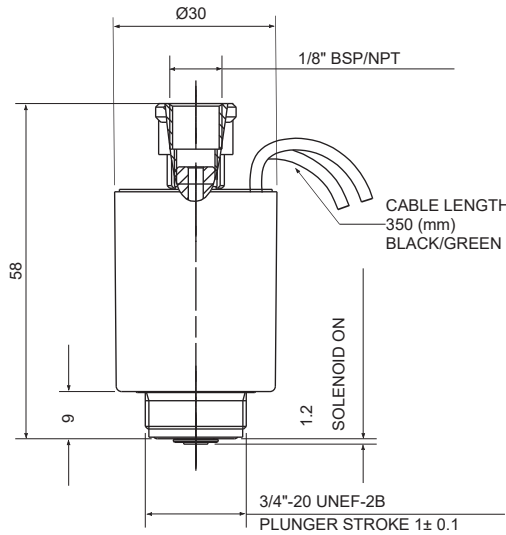

3 Way NC / 3 Way NO

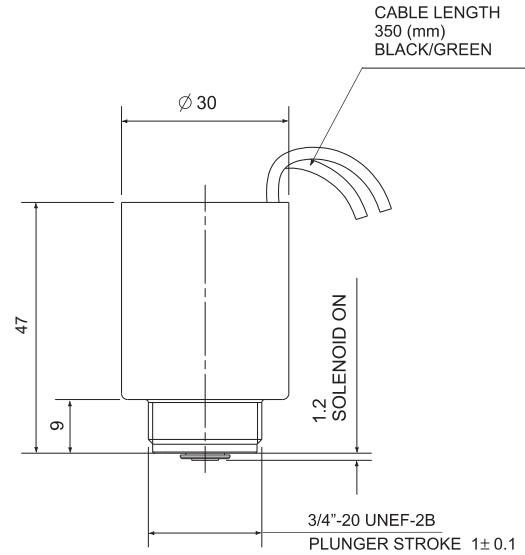

2 Way NC

How to Order

2 Way

G75-O	FUNCTION	VOLTAGE VDC (1)	WIRES
	2W NC 1	4Ω B	two null

3 Way

G75-O	PORT	FUNCTION	ORIFICE	VOLTAGE VDC (1)	WIRES
	1/8" BSP 10	3W NC 3	1.0 1	9Ω C	three a
	1/8" NPT 11	3W NO 4	1.2 2	12Ω D	
			1.6 3	23Ω 6	

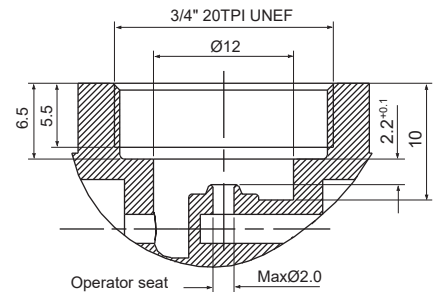

Latch Coil Resistance vs Input Voltage

Recommendations chart

Resistance [Ω]	Input voltage range [V]
4	6 - 9
9	12 - 14
12	14 - 16
23	18 - 21

Example: G75-O-1-B

GEM-FLOW™ G75 Latch solenoid operator, 2W NC, 4Ω, 2 wires

Example: G75-O-1042-Ca

GEM-FLOW™ G75 Latch solenoid operator, 1/8" BSP, 3W NO, 1.2 orifice, 9Ω, 3 wires

(1) Refer to Latch Coil Resistance vs Input Voltage | Recommendations chart

* To order operators manufactured according to your specific requirements, please contact our technical sales department



TECHNICAL INFORMATION

Valve Functions	108
Operating Mechanism	109
Valve Sizing	110
GEM-SOL® Elastomer Materials	111
Flow Chart for Liquids	112
Flow Chart For Gases	113
Operation Driver for Latch Coils	114
Conduits Sizing	115
Long Distance Operators Charts	116



Valve Functions

Two way valves have one orifice and two ports: one inlet and one outlet. They are available with the following functions:

- Normally Closed (NC) Fig. 1 - valve is closed for flow through the valve when the coil is de-energized.
- Normally Open (NO) Fig. 2 - valve is open for flow through the valve when the coil is de-energized.

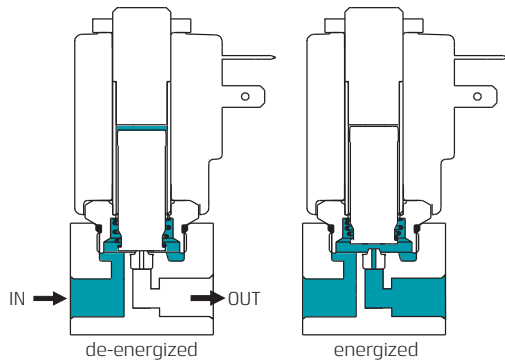

Fig. 1

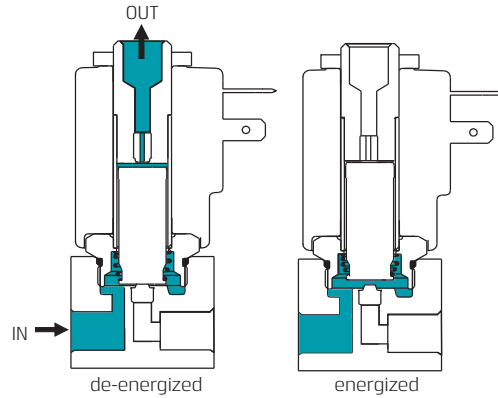

Fig. 2

Three way valves have two orifice and three ports: inlet, outlet and exhaust. They are available with the following functions:

- Normally Closed (NC) Fig. 3 - no flow from inlet port, flow is from outlet port to the exhaust.
- Normally Open (NO) Fig. 4 - flow from inlet port, no flow from the exhaust port.

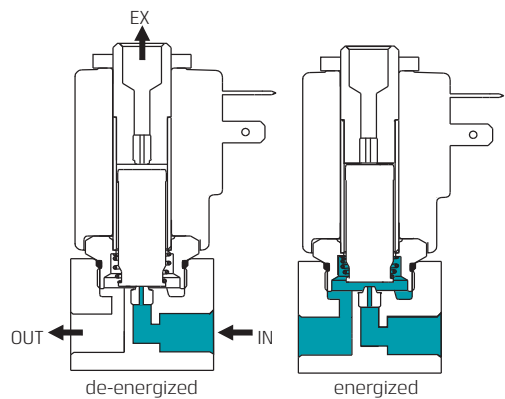

Fig. 3

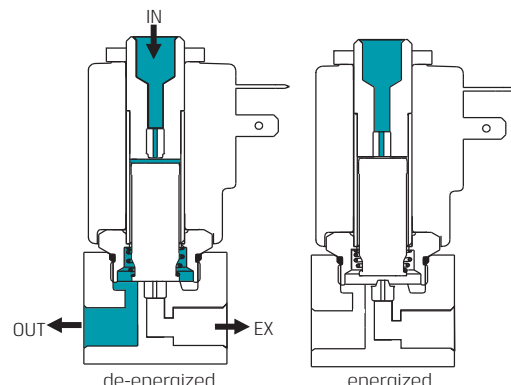

Fig. 4

Also available are the following non-standard functions: Divertor Fig. 5 - one inlet pressure with two outlets, one outlet is NO and the other NC. Selector Fig. 6 - two inlet pressures, one inlet is NO and the other NC.

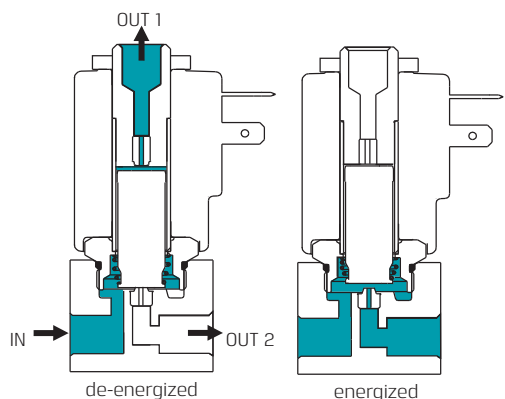

Fig. 5

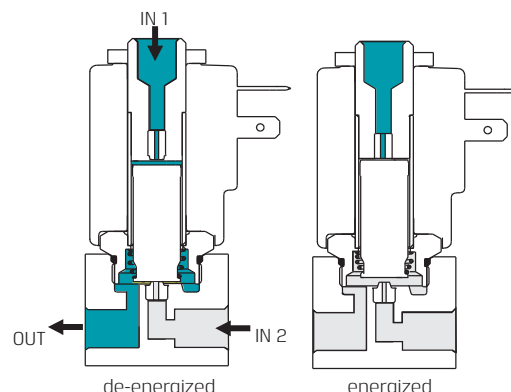

Fig. 6

Operating Mechanism

A solenoid valve is a combination of two functional units:

- A solenoid (electromagnet) with a moving core (plunger).
- A valve body containing the right orifices and seals mechanism.

The plunger in a solenoid valve moves and changes the flow direction when a current is supplied to the electromagnet.

There are two basic types of Baccara GEM-SOL® valves:

Direct operated solenoid valves

When the solenoid is energized in a direct acting valve, the plunger moves and directly acts on the valve disc to open, close or change the flow direction. Direct acting valves' performance depends directly on the orifice pressure and the magnetic power. The increase of line pressure or the orifice size requires more power from the electromagnet.

Pilot operated solenoid valves

These valves are recommended for applications where high flow at high pressure is required. A pilot chamber is used which is controlled by a direct acting solenoid valve. The movement of the plunger changes the pressure in the pilot chamber.

When there is pressure in the pilot chamber the valve is closed. GEM-SOL® pilot valves are equipped with diaphragm, according to the valve function.

- Two way valves have a bleeding passage in the diaphragm, through which the pilot pressure flows into the pilot chamber; and one orifice to release the pressure when the solenoid is energized.
- Three way valves have a three way pilot solenoid to control the pilot chamber pressure.
- Pilot operated valves require a minimum operating pressure.

Zero differential valves

We also manufacture a two way pilot operated valve which works without differential pressure. For this type of valve, a mechanical spring helps to lift the diaphragm.

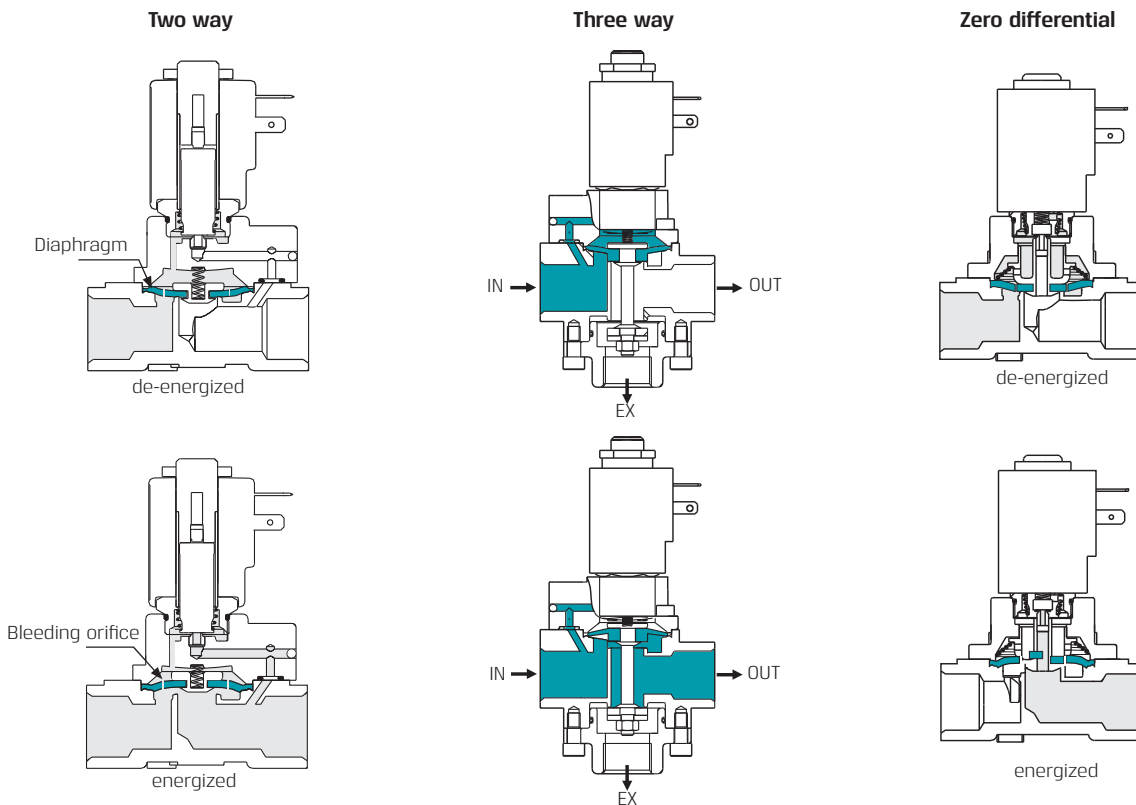

Valve Sizing

General

It is not recommended to select a solenoid valve according to its pipe connection port or its orifice size. The valve selection depends on the knowledge of the following factors: pressure range minimum and maximum, differential pressure, minimum and maximum flow rate, the specific gravity of the fluid, temperature, viscosity, etc.

Pressure

The pressure is generally measured above the atmospheric pressure and is expressed in kg/cm² or bars of relative pressure. The value of pressure terms in this catalog corresponds to the relative pressure.

Pressure drop ΔP

This is the difference of pressure between the upstream P1 and the downstream P2 of the valve when it is crossed by the fluid.

Differential pressure

Minimum - maximum

This is the minimum or maximum difference of pressure between the upstream P1 and the downstream P2 which secures perfect functioning of the device. Only a pilot operated solenoid valve requires the minimum differential pressure to operate.

Flow - the flow factor Kv (Cv)

The flow of a solenoid valve is the quantity of fluid per time units crossing the valve under certain conditions. It is this factor which determines its size. To obtain a simpler method of calculation and comparison between the various types of valves, all variables permitting the calculation of the flow have been reduced to a common denominator: the flow factor Kv (without units). The Kv factor can be determined by the flow chart or by calculation. When the Kv factor is determined, select the solenoid valve which has the equivalent flow factor. The flow factor values given in this catalog have been set up according to the following method:

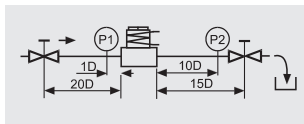

Fluid is water, specific gravity 1 kg/dm³ the pressure drop P1, P2 is 1Kg/cm² in a way that the Kv is equal to the flow in liter/min.

$$Q = Kv \sqrt{\frac{\Delta P}{\gamma}} \quad Kv = Q \sqrt{\frac{\gamma}{\Delta P}}$$

When several valves are mounted in series, the resulting flow factor is equal to:

$$\frac{1}{Kv_{Tot}^2} = \frac{1}{Kv_1^2} + \frac{1}{Kv_2^2} + \frac{1}{Kv_3^2} + \dots + \frac{1}{Kv_n^2}$$

When several valves are mounted in parallel, the resulting flow factor is equal to:

$$Kv_{Tot} = Kv_1 + Kv_2 + Kv_3 + \dots + Kv_n$$

Unit conversion
Kv = flow factor (decimal units)
to convert
CV(USA) = 0.070Kv
f(UK) = 0.0585Kv
Kv = 14.28 Cv (USA)
Kv = 17.11 f (UK)

Viscosity

Practically, the flow Kv is identical for a valve crossed by water or a medium having up to 3°E viscosity. The flow/pressure characteristic is effected above this limit. It is necessary to consider factor above 3°E - the flow factor Kv will be:

$$Kv_x = Kv_{water} \cdot C$$

$$C = \frac{\delta \sqrt{Kv}}{200 Q} + 1$$

δ = kinematic viscosity (in centistokes) of the fluid

Q = flow in liter/min

Kv = flow factor given in catalog

This calculation leads to a choice of a valve with a higher flow factor value than the one which would have been chosen for a fluid having a viscosity of 3°E.

Temperature

The limits of temperature of use of a solenoid valve depend essentially upon the nature of the discs and the design of the coil. The temperature developed in a solenoid valve is a function of the electrical characteristics of the coil, the duty cycle, the fluid and ambient temperatures. These parameters determine the "temperature of use".

For each type of solenoid valve, the temperature range is given in the technical data, however these figures are only a general guide. If temperature of use might extend the given limits, please contact our technical sales department.

Response time

The response time of a solenoid valve is the lapse of time between the electric signal and the outlet of fluid signal. The response time is effected by the following parameters: Valve function, operating mode, orifice size, inlet pressure and pressure differential, fluid, temperature and coil characteristics. The C.E.T.O.P defines the test of conditions as follows:
Test pressure: air at 6Kg/cm² - 85 PSI
Ambient temperature: 200 C - 680 F

Response time at energizing

Response time at energizing of the solenoid and until the outlet pressure reaches 90% of the test pressure.

Response time at de-energizing

Lapse of time between de-energizing of the solenoid and until the pressure outlet drops to 10% of the test pressure, see schemas of measure method and resulting curves for AC and DC current.

Average response time for GEM-SOL® valves can be assumed as follows:

- Direct acting solenoids 16 to 36 ms for complete cycle.
- Large direct acting solenoids 40 to 80 ms for complete cycle.
- Pilot operated valve 20 to 80 ms for complete cycle.

Cycling rate

The cycling rate of a solenoid depends directly on its response time. It is the number of cycles per minutes calculated for continuous operation. The valve should not be reversed at less than 90% or above 10% at discharging of reference pressure.

$$\text{Cycles/Minutes} = \frac{60 \text{ sec}}{R_{T_e} + R_{T_d}}$$

R_{T_e} = response time at energizing (sec)
R_{T_d} = response time at de-energizing (sec)

The cycling rate is the maximum possible cycles per minute of the solenoid valve. It varies when the valve is mounted in a circuit and depends then upon the installation pressure drop.

GEM-SOL[®] Elastomer Materials

General information

GEM-SOL[®] solenoid valves can be used for many fluid types including acids, gases, solvents etc. To ensure appropriate functioning of the valve, particular care must be taken with the selection of the valve and seals materials. The information below summarizes the elastomers materials used for GEM-SOL[®] valves.

Please contact our technical department for further information.

NBR or BUNA-N

- NBR is a copolymer of butadiene and acrylonitrile. It is the most used elastomer in the seals industry and is the standard elastomer for GEM-SOL[®] valves.
- NBR is suitable for use from -20°C to 85°C. It has benefits over other elastomers with its compression set, tear and abrasion resistance.
- Air, cold water and inert gases are some of the materials NBR is recommended for.

EPDM - Ethylene Propylene Rubber

- EPDM is an elastomer made from ethylene and propylene monomers. It has a wider temperature range than NBR, -40°C to 149°C. Its main disadvantage is that it cannot be used with petroleum oils.
- Water, alcohol and acetone are some of the materials EPDM is recommended for.

Neoprene

- Neoprene is homopolymers of chloroprene. It has a temperature range of -20°C to 85°C. Neoprene is unusual because it is resistant to both oxygen and petroleum.
- Refrigerants, oxygen and petroleum oils are some of the materials Neoprene is recommended for.

FKM

- FKM is a very important elastomer due to its wide compatibility to chemicals. It has a temperature range of -20°C to 180°C. This gives FKM a significant advantage over NBR, but it is still not the ultimate elastomer.
- Diesel oil, gasoline, some acids and trichlorethylene are some of the materials FKM is recommended for.

Flow Chart for Liquids

Kinematic viscosity: Max. 3° Engler

Spec. gravity
 γ (Kg/dm³)



Flow factor
Kv

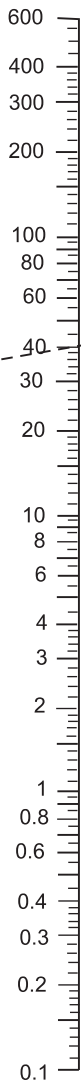

Flow rate
Q (l/min)



Pressure drop
 Δ_p (bar)

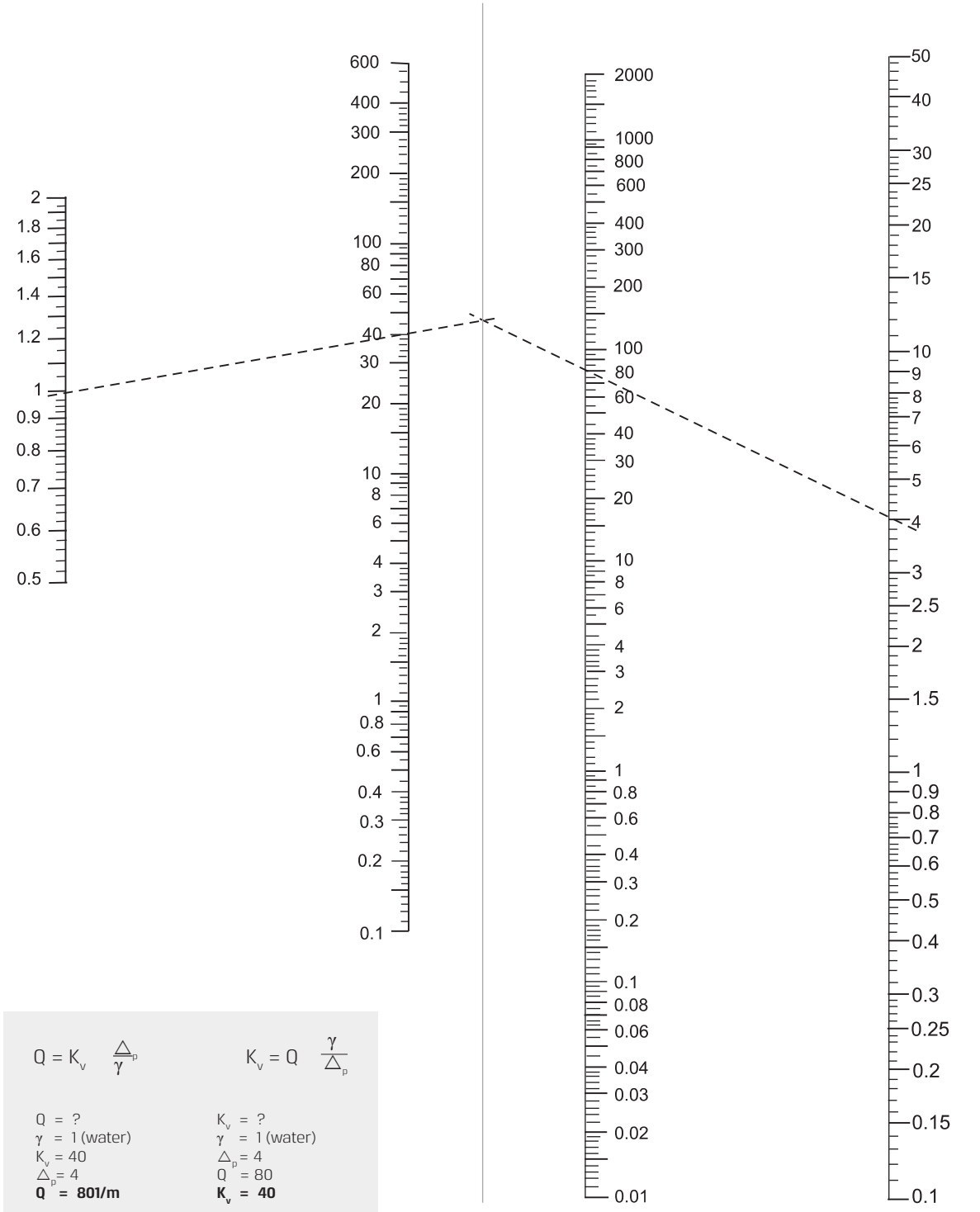
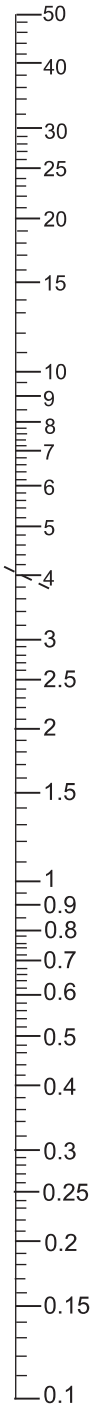

$Q = K_v \frac{\Delta_p}{\gamma}$	$K_v = Q \frac{\gamma}{\Delta_p}$
Q = ?	Kv = ?
$\gamma = 1$ (water)	$\gamma = 1$ (water)
Kv = 40	Delta_p = 4
Delta_p = 4	Q = 80
Q = 80 l/m	Kv = 40

Flow Chart For Gases

Spec. gravity
 γ_N (Kg/m³)

Flow factor
Kv

Flow rate
QN (Nm³/h)

Pressure drop
 Δ_p (bar)

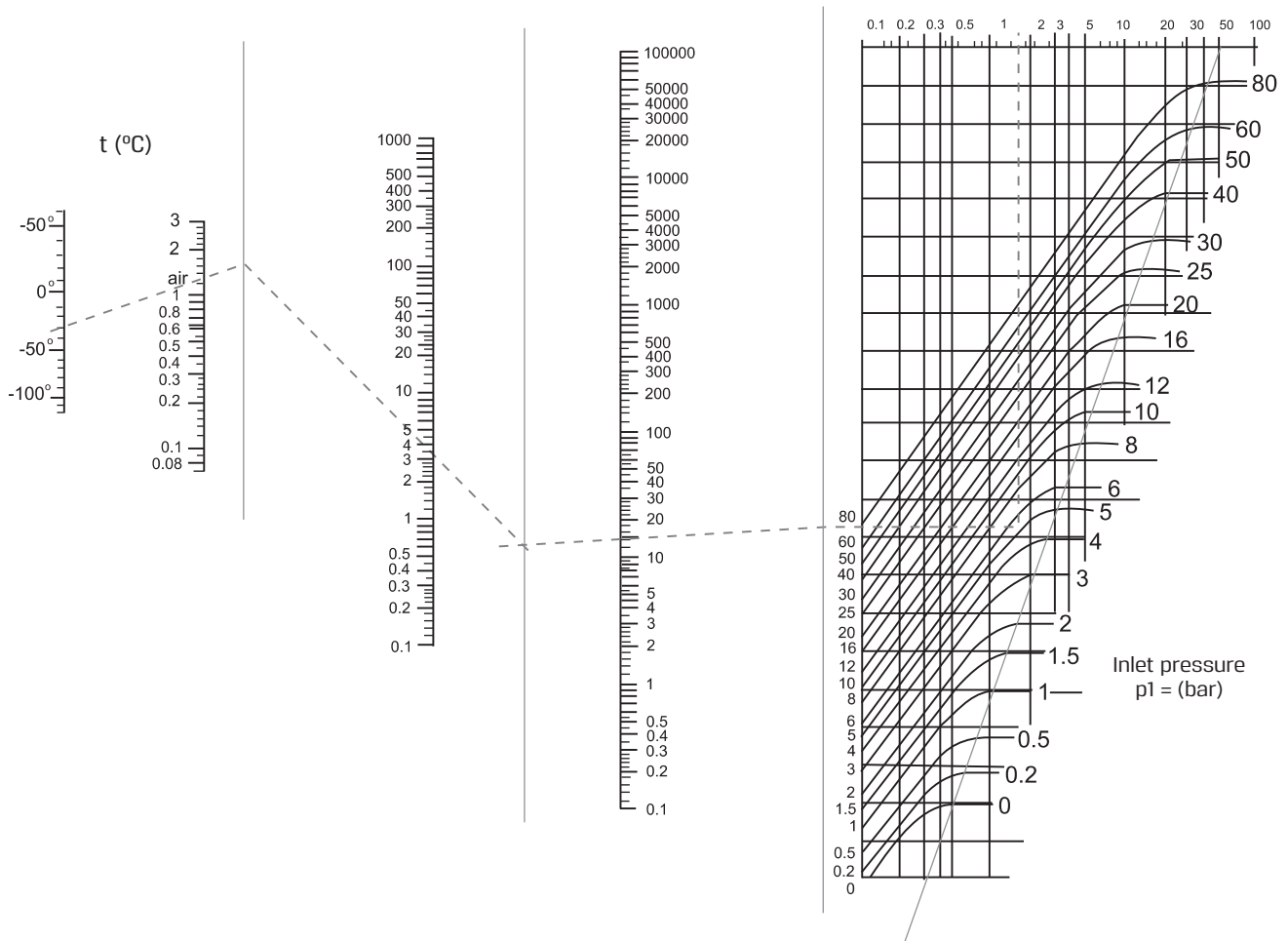

QN = ?	Kv = ?
t = 25	t = 25
γ_N = 1.3 (air)	γ_N = 1.3 (air)
Kv = 3	QN = 12
p1 = 5	p1 = 5
Δ_p = 1.8	Δ_p = 1.8
QN = 12 Nm³/h	Kv = 3

Operation Driver for Latch Coils

Non-direct operation with two switches (or four transistors)

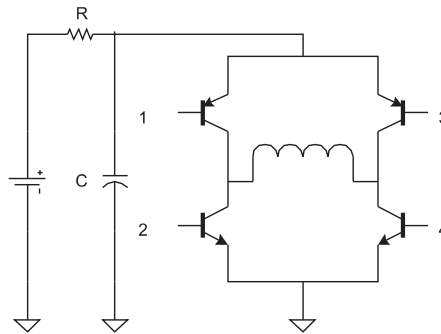
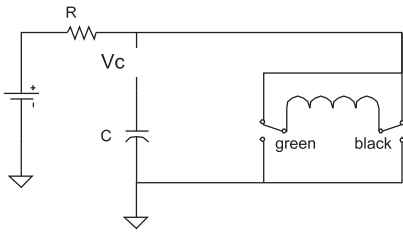

T_{vc} is the time to charge the capacitor. In order to reduce the time, use a similar resistor but never less than 100Ω .

$C = 4700\mu F$

$T_{vc} = 5 \cdot R \cdot C$ [sec]

$t_{on/off} = 30 \div 50$ ms

Non-direct operation with one switch (or transistor)

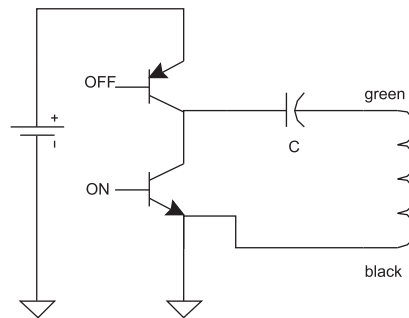
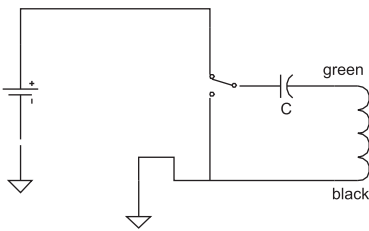

$C = 4700\mu F$

$t_{on/off} = 30 \div 50$ ms

Direct operation

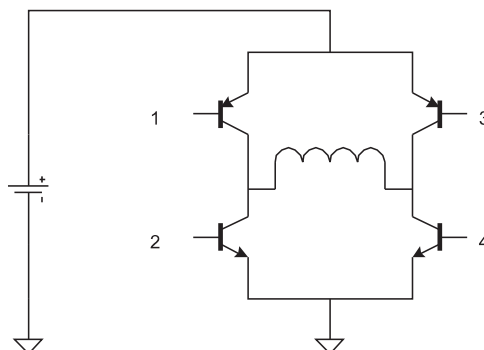
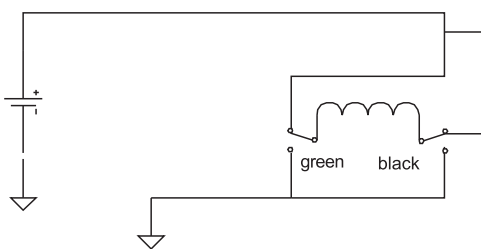

Conduits Sizing

GEM-SOL®

Wires cross-section selection for distance installation of GEM-SOL® solenoids

Solenoid type: GEM-SOL® 8W 24V AC					
No. of solenoids	1	2	3	4	Distance
Cross-section [mm ²]	1.0	1.5	2.5	4.0	100m
	1.5	4.0	6.0	6.0	200m
	2.5	6.0			300m
	4.0	6.0			400m
	4.0				500m
	6.0				600m
	6.0				700m
	6.0				800m
					900m
				1000m	

Max. conduits resistance 4

Solenoid type: GEM-SOL® 5.5W 24V AC					
No. of solenoids	1	2	3	4	Distance
Cross-section [mm ²]	0.75	1.5	2.5	2.5	100m
	1.5	2.5	4.0	6.0	200m
	2.5	4.0	6.0		300m
	2.5	6.0			400m
	4.0				500m
	4.0				600m
	6.0				700m
	6.0				800m
	6.0				900m
				1000m	

Max. conduits resistance 5

G75

Wires cross-section selection for distance installation of G75 solenoids

Solenoid type: G75 24V AC					
No. of solenoids	1	2	3	4	Distance
Cross-section [mm ²]	0.5	0.5	0.75	1.0	100m
	0.5	1.0	1.5	2.5	200m
	0.75	1.5	2.5	2.5	300m
	1.0	2.5	2.5	4.0	400m
	1.5	2.5	4.0	6.0	500m
	1.5	4.0	4.0	6.0	600m
	2.5	4.0	6.0	6.0	700m
	2.5	4.0	6.0		800m
	2.5	4.0	6.0		900m
	2.5	6.0			1000m

Max. conduits resistance 15

Solenoid type: G75 latch 4Ω					
No. of solenoids	1	2	3	4	Distance
Cross-section [mm ²]	0.75	1.5	1.5	2.5	10m
	1.5	2.5	4.0	6.0	20m
	1.5	4.0	6.0	6.0	30m
	2.5	6.0	6.0		40m
	4.0	6.0			50m
	4.0				60m
	4.0				70m
	6.0				80m
	6.0				90m
	6.0				100m

Max. conduits resistance 0.6

Long Distance Operators Charts

LDOS32 (LDOS) | Long distance operating solenoid

Number of solenoids that operate simultaneously as a function of wire cross-sectional [mm ²] area and distance [mt] from energy source				
Distance in meters from energy source	WIRE CROSS-SECTIONAL AREA [mm ²]			
	0.50	1.00	1.50	2.50
200	12	25	38	65
400	6	12	19	40
600	4	8	12	21
800	3	6	9	16
1,000	2	5	7	13
1,500	1	3	5	9
2,000	1	2	3	6
2,500	1	2	3	5
3,000		1	2	4
3,500		1	2	4
4,000		1	2	3
5,000		1	1	2
6,000			1	2
7,000			1	1
8,000			1	1
9,000				1
10,000				1

Wire's maximum resistance for one solenoid is 175

For further technical information, please refer to product pages in Controllers & Special section



LDOS32 (LDOS) assembled with S32 (GEM-S) solenoid

G75-LDO | Long distance operator 2 Way, 3 Way NC, NO

LD032 (GEM-LDO) | Long distance operator 2 Way, 3 Way NC, NO

Number of solenoids that operate simultaneously as a function of wire cross-sectional [mm ²] area and distance [mt] from energy source				
Distance in meters from energy source	WIRE CROSS-SECTIONAL AREA [mm ²]			
	0.50	1.00	1.50	2.50
200	24	56	78	130
400	12	28	39	65
600	8	18	26	43
800	6	14	19	32
1,000	4	11	15	26
1,500	3	7	10	17
2,000	2	5	7	13
2,500	2	4	6	10
3,000	1	3	5	8
3,500	1	3	4	7
4,000	1	2	3	6
5,000	1	2	3	5
6,000		1	2	4
7,000		1	2	3
8,000		1	1	3
9,000		1	1	2
10,000		1	1	2

Wire's maximum resistance for one solenoid is 390

For further technical information, please refer to product page in Controllers & Special section



G75-LDO | assembled with G75-A operator & solenoid

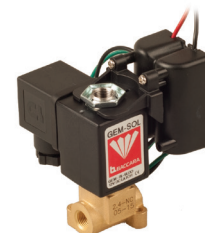

LD032 (GEM-LDO) assembled with A32 (GEM-A) solenoid

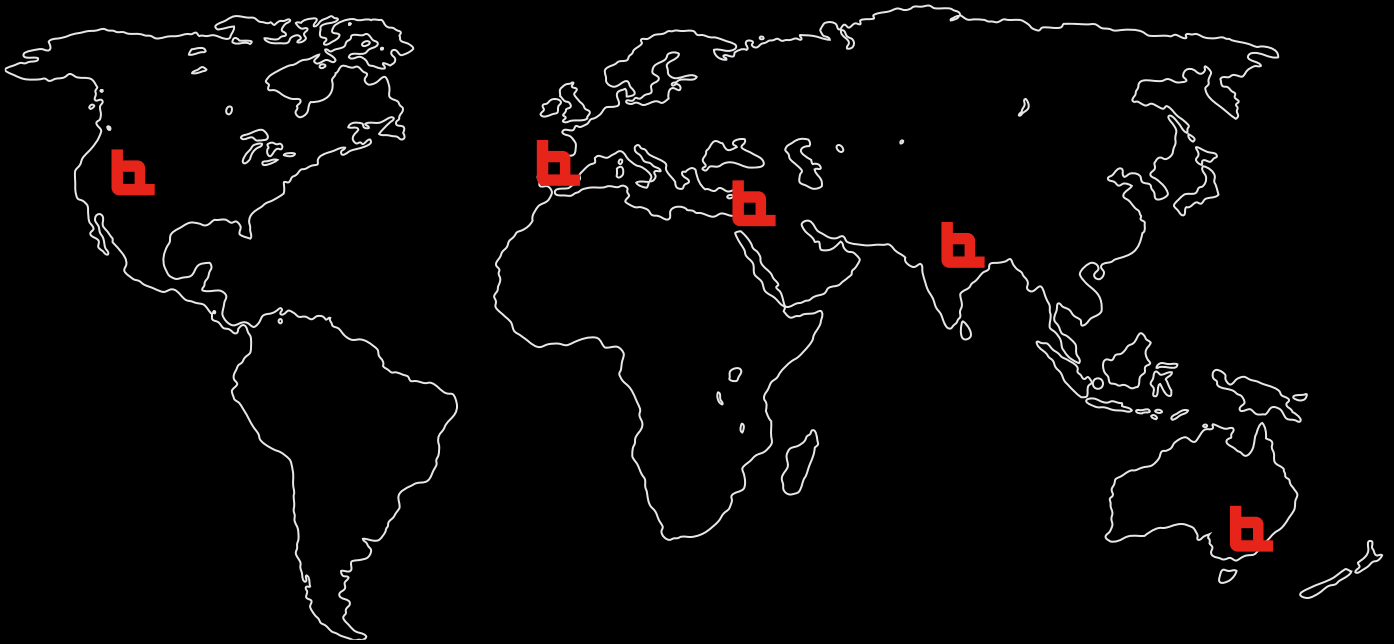

BACCARA

BACCARA Corporate Headquarters

Kvutzat Geva, 1891500,
Israel
T. +972 4 653 5960
F. +972 4 653 1445
info@baccara-geva.com
www.baccara-geva.com

Baccara Australia Pty Ltd.

6 Jacks Road, Oakleigh South,
Victoria 3167,
Australia
T. +61 3 9570 2130
www.baccara-geva.com/australia/
Online Store: www.baccarastore.com.au

Baccara Automation S.L.U.

Avenida De La Industria,
38, Nave A-15
28823 - Coslada (Madrid)
Spain
T. +34 91 344 6310
F. +34 91 344 6311
spain@baccara-geva.com
www.baccara-geva.com/es/

Baccara USA

1312 W Stanford Ave,
Englewood, CO 80110,
USA
T. +1 720 221 3221
info.us@baccara-geva.com
www.baccara-geva.com/usa/

Baccara India

Empirical Business Center, Office
no. 405, Navale Icon, Near Navale
Bridge, Off NH4, Narhe, Pune. PIN-
411041. [Maharashtra]
M. +91 91 685 27007
india@baccara-geva.com

