

General maintenance

Make sure the valve is disconnected from media supply or electrical ancillaries before attempting to do any maintenance. Clean and inspect all the internal parts and replace them if necessary with original spare parts available, as indicated in the catalogue. (See image 5)

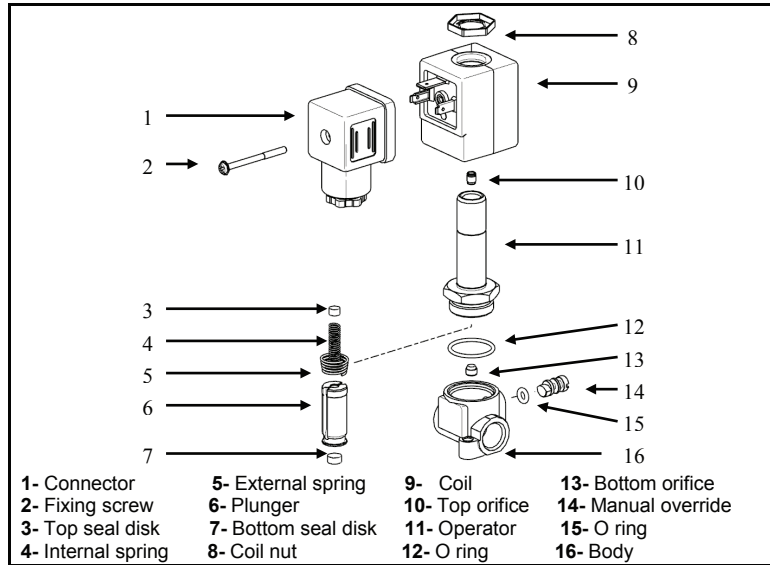

Image 5

Lubrication

The valve comes pre lubricated and under normal operating conditions does not require re-lubrication.

Consult Baccara technical staff for correct lubricants regarding the solenoid valve in use and the application in use (industrial, oxygen, drinking water etc.)

Specifications: see product catalog

Materials

Valve body: AISI 316 / BRASS / ALUMINUM / ZINC CASTING

Valve seals: EPDM /NBR/FPM / SILICON / POLYURITHAN etc.

Mounting screws: Stainless steel / ZINC PLATED STEEL

Operator: Stainless steel

Plunger and top orifice: Stainless steel

Manual override: Stainless steel /BRASS

Springs: Stainless steel

Baccara Geva Ltd. | Kvutzat Geva | 1891500 | Israel | T. +972 4 6535960 | F. +972 4 6531445
info@baccara-geva.com | www.baccara-geva.com



Baccara Direct operated GEM-A series valves 1/8" - 1/2"

Installation, Operation and Maintenance

General

- For safe use of the solenoid valve please read the entire IOM before using the valve.
- The user must recognize and follow all applicable industry specifications on safe installation and usage of the product.
- Misuse of the product may result in injuries or property damage.

Please contact Baccara for additional information.

Direct operated valves are designed for industrial control systems, fluid transporting systems and irrigation systems.

Installation

- Qualified personal only trained in maintenance and have read the instructions are permitted to assemble or disassemble the valve.
- Before mounting the valve it is essential to check that the solenoid valve model's voltage (Volt) and the frequency (Hz), correspond to the characteristics required.
- It is recommended to use an upstream filter where impurities, slag or deposits may enter the fluid.
- We recommend using mufflers on all exposed ports.
- To mount the valve use two M5 screws. (See image 1 on page 2)

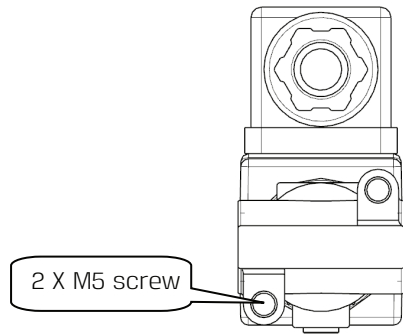

Image 1

To connect the system to the valve's ports refer to the functional scheme. (See image 2)

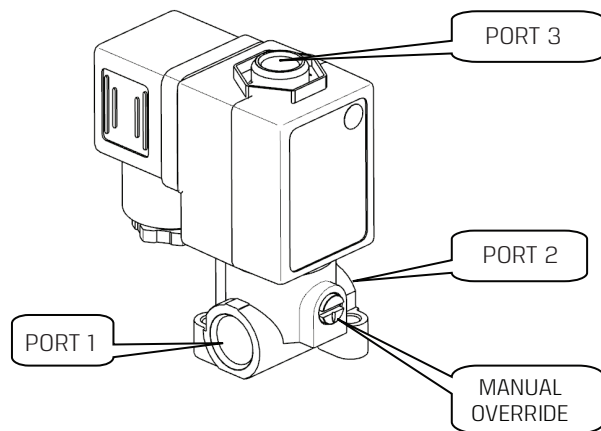

Image 2

Manual override operation

The manual override is made for manual operation of the valve when it is in an de-energized state or upon loss of power.

Electrical connections

- All wiring must comply with local and national codes.
- The coil should not be energized before being installed on the valve, since this could cause it to burn out.

Wiring instructions for DIN connectors

1. Pass the cable through the housing and wire to the terminal block marked as follows (see image 4):
 - 1 Live / +ve
 - 2 Neutral / -ve
 - 3 Earth / Ground
2. Tighten the cable gland (nut, washer and Rommel) to prevent straining connections or allowing moisture admission.

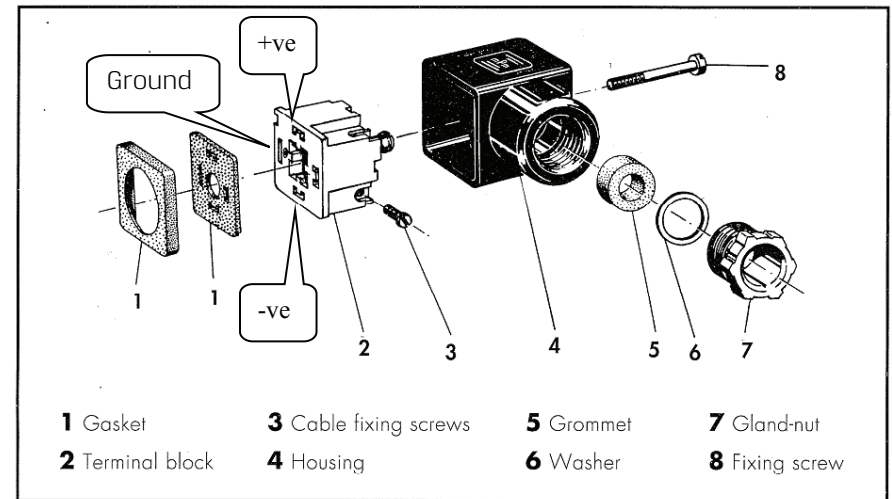

Image 4