

## Lubrication

---

The valve comes pre lubricated from the factory and under normal conditions does not require re-lubricating.

Please consult Baccara technical staff for correct lubricants with regards to the solenoid which is in use and the application used (industrial, drinking water etc.)

## Materials

---

Valve body: NYLON 6 + 33%GF

Valve seals: EPDM , NBR

Operator: Stainless steel

Plunger and top orifice: Stainless steel

Manual override: NYLON 6 + 33%GF

Springs: Stainless steel



## Baccara Pilot operated G75-S series valves 1-1/2" - 2" Handle Override

### Installation, Operation and Maintenance

#### General

---

- For safe use of the solenoid valve please read the entire IOM before using the valve.
- The user must recognize and follow all applicable industry specifications on safe installation and usage of the product.
- Misuse of the product may result in injuries or property damage.

Please contact Baccara for additional information.

G75 Pilot operated valves are designed for industrial control systems, fluid transporting and irrigation control.

#### Installation

---

- Qualified personal only trained in maintenance and have read the instructions are permitted to assemble or disassemble the valve.
- Before mounting the valve it is essential to check that the solenoid valve model's voltage (Volt) and the frequency (Hz), correspond to the characteristics required.
- It is recommended to use an upstream filter where impurities, slag or deposits may enter the fluid.
- Media lines should be large enough to avoid excessive pressure loss under conditions of maximum flow. Sharp turns in piping should be avoided for more efficient media flow.
- This is an inline type valve without mounting threads. Connect the system to the valve's inlet and outlet. (See image 1 on page 2)

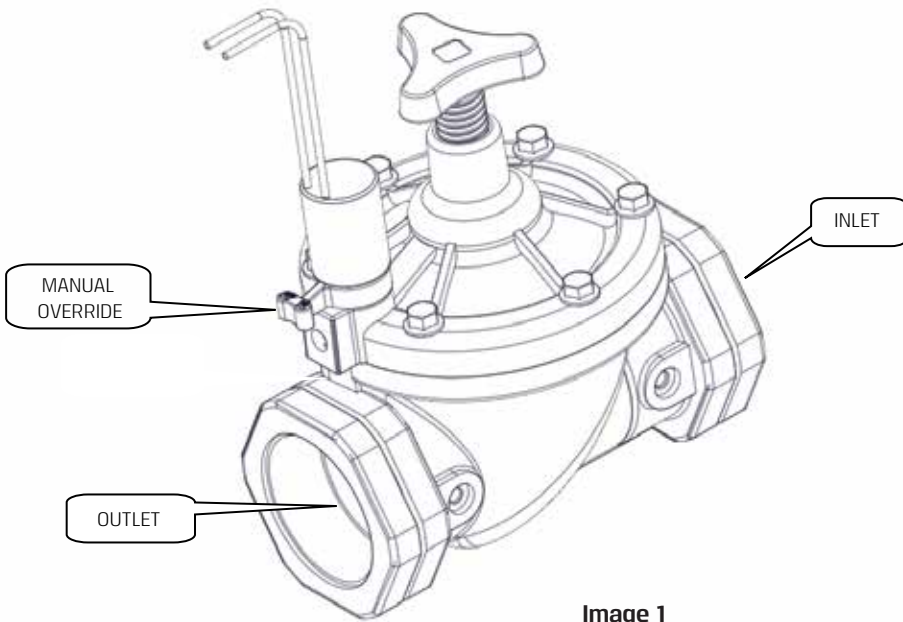

Image 1

### Manual override operation

The manual override is made for manual operation of the valve when it is in an de-energized state or upon loss of power.

### Electrical connections

- All wiring must comply with local and national codes.
- The coil should not be energized before being installed on the valve, since this could cause it to burn out.

### General maintenance

Make sure the valve is disconnected from media supply or electrical ancillaries before attempting to do any maintenance. Clean and inspect all the internal parts and replace them if necessary with original spare parts available, as indicated in the catalogue. (See image 2)

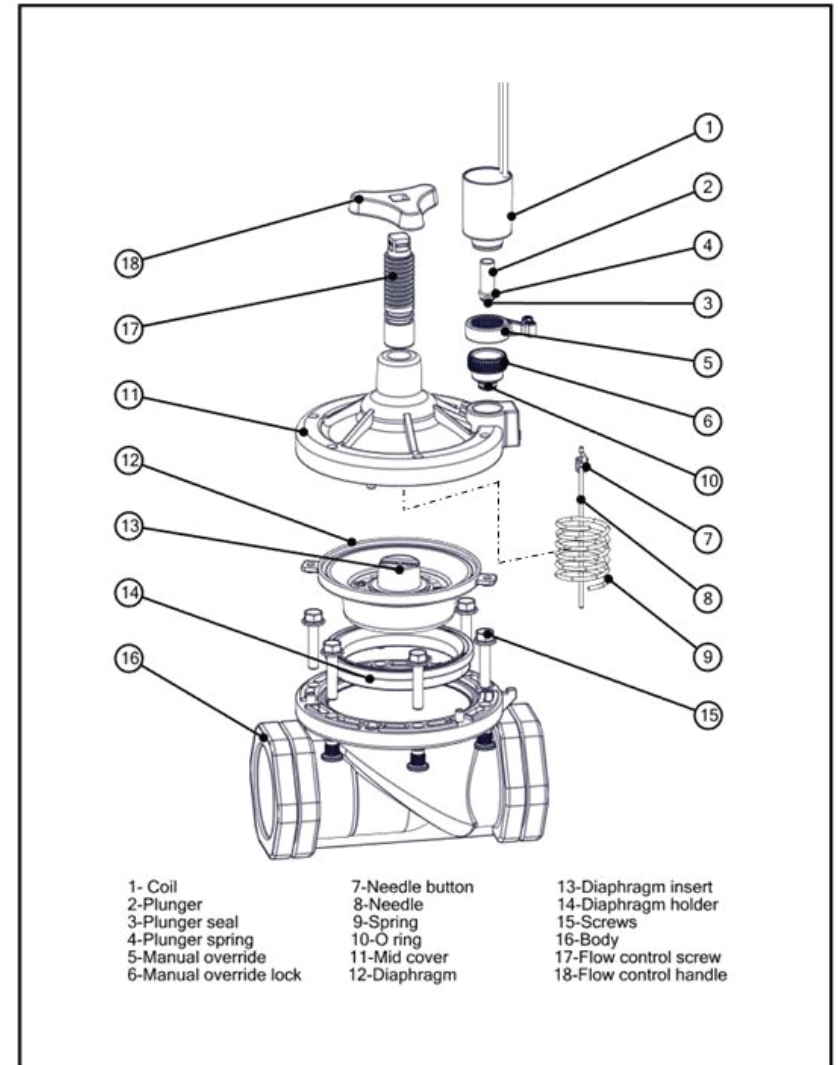

Image 2