

# PRECISION BALL SCREWS

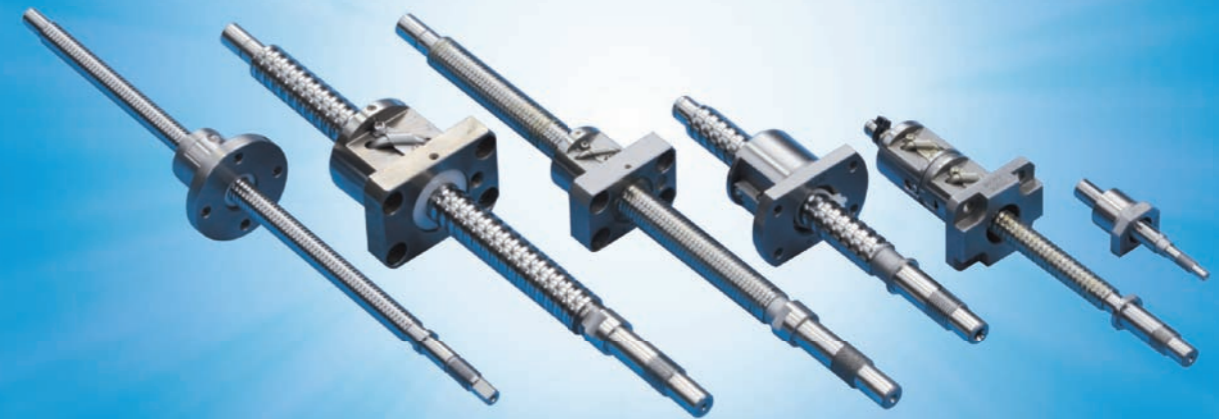

## NIDEC SANKYO CORPORATION

### Tokyo Office

Nidec Tokyo Bld., 1-20-13 Osaki, Shinagawa-ku, Tokyo 141-0032, Japan  
TEL:81(3)-5740-3000 FAX:81(3)-6843-3122

**NIDEC SANKYO CORPORATION**

## Contents

1. FEATURES .....	1
2. ACCURACY.....	2
3. NOTATION OF SANKYO PRECISION BALL SCREWS	6
4. DESIGN OF SCREW SHAFTS .....	7
5. DESIGN OF NUTS .....	13
6. DESIGN FOR ACCURACY .....	15
7. DESIGN OF RATED LIFE .....	19
8. DRIVING TORQUE.....	21
9. LUBRICATION AND DUST-PROOFING .....	22
10. GEOMETRY OF NUTS .....	23
11. SHAFT END MACHINING SERIES.....	62
12. MANUFACTURING, ASSEMBLING & INSPECTION FACILITIES .....	86
13. HANDLING PRECAUTIONS FOR BALL SCREWS .....	87

# 1. FEATURES

## (1) High transmission efficiency

Sankyo ball screws have an extremely high transmission efficiency of over 90%, as compared with the conventional Acme screws, and the required torque reduced to only one-third or less. This allows the effective conversion of linear motion to rotary motion. (See Chart on the next right.)

## (2) Axial clearance adjustable

Conventional Acme screws do not roll smoothly when the axial clearance is small. Sankyo ball screws, however, can roll smoothly even when the axial clearance is reduced.

In addition, Sankyo ball screws can eliminate the axial clearance by preloading with two nuts and also resulting in increased rigidity.

## (3) Long life and low wear

Due to rolling contact, very little wear occurs over the life of the ball screws, assuring high precision performance for long period of time.

## (4) Precision fine feed possible

Reduced starting torque due to the rolling contact permits precision fine feed.

## (5) High precision

All Sankyo ball screws are ground, assembled and inspected under a strict temperature control.

## (6) Drastic quality control system

Sankyo has promptly obtained a qualification for ISO9001 and established a drastic quality control system to manufacture quality products that can satisfy customers' needs to the full.

Fig.1 Efficiencies of Ball Screw and Acme Screw

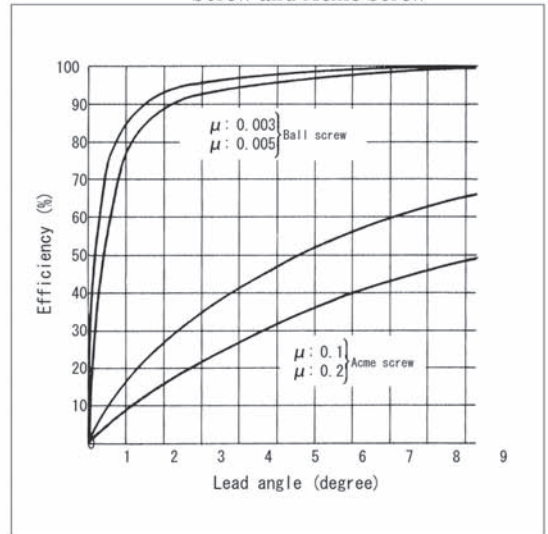

# 2. ACCURACY

## 2.1 Accuracy Grade

The grade of accuracy of Sankyo Precision Ball Screws conforms to JIS B 1192 (Ball Screws) and is prescribed by JIS Series (C0, C1, C3, C5) and (G1, G3, G5) conforming to ISO.

## 2.2 Lead Accuracy

Lead Accuracy for Sankyo Precision Ball Screws conforms to JIS B 1192 (Ball Screws) which prescribes the tolerance on specified travel and travel variation in respect to the effective length of travel of nut or to the effective length of threaded portion of screw shaft, as well as on travel variation in respect to a length of 300mm taken arbitrarily within the effective length of the screw shaft and on travel variation in respect to arbitrary one revolution ( $2\pi$  rad) within the effective length of threaded portion.

Fig. 2 Terms of lead accuracy

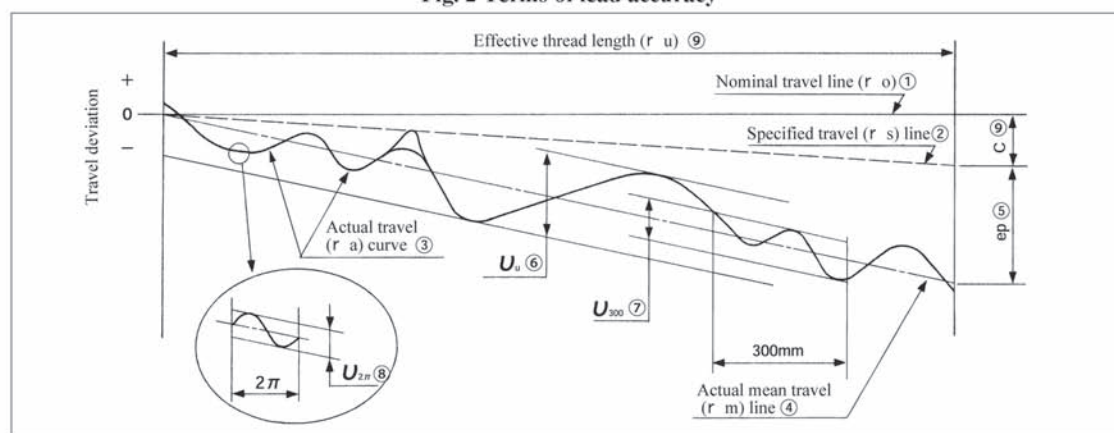

### 2.2.1 Terms and Definitions of Lead Accuracy

#### (1) Specified lead

Lead that is calculated by correcting the nominal lead to some degree to compensate the amount of deformation which may occur due to temperature rise or load.

#### (2) Specified travel $r_s$

Axial travel attained when screw shaft has been rotated by arbitrary number of times in accordance with specified travel. [② in Fig. 2]

#### (3) Actual travel $r_a$

Axial travel obtained by continuous measurement of the actual axial travel of nut to arbitrary angle of screw shaft rotation. [③ in Fig. 2]

#### (4) Actual mean travel $r_m$

Straight line representing the tendency of actual travel. This straight line can be obtained by the least square method or a simple and appropriate approximation method similar to that, from a curve indicating the actual travel in respect to the effective travel of the nut or the effective length of threaded portion of the screw shaft. [④ in Fig. 2]

#### (5) Tolerance on specified travel $ep$

Difference between actual mean travel corresponding to the effective travel of the nut or the effective length of threaded portion of the screw shaft and specified travel. [⑤ in Fig. 2]

#### (6) Travel variation $v$

The maximum width of actual travel curve put between 2 straight lines drawn in parallel to actual mean travel line, and it is specified on the following 3 items.

$v_u$  : That corresponds to the effective travel distance of nut or effective length of threaded portion of the screw shaft. [⑥ in Fig. 2]

$v_{300}$  : That corresponds to a length of 300mm which is arbitrarily taken within the effective threaded portion of the screw shaft. [⑦ in Fig. 2]

$v_{2\pi}$  : That corresponds to one arbitrary revolution ( $2\pi$  rad) within the effective threaded portion of screw shaft. [⑧ in Fig. 2]

#### (7) Target value $C$ of specified travel

Target value used to preset specified travel to "minus" or "plus" side against nominal travel. [⑨ in Fig. 2]

**Table 1. Tolerance on specified travel and Travel variation (Permissible Values)**

Unit:  $\mu\text{m}$

Grade		C0		C1		C3		C5		G1		G3		G5	
Items		Tolerance on specified travel	(1) Travel variation	Tolerance on specified travel	(1) Travel variation	Tolerance on specified travel	(1) Travel variation	Tolerance on specified travel	(1) Travel variation	Tolerance on specified travel	(1) Travel variation	Tolerance on specified travel	(1) Travel variation	Tolerance on specified travel	(1) Travel variation
Over	Not more than	$\pm e_p$	$V_u$	$\pm e_p$	$V_u$	$\pm e_p$	$V_u$	$\pm e_p$	$V_u$	$\pm e_p$	$V_u$	$\pm e_p$	$V_u$	$\pm e_p$	$V_u$
—	100	3	3	3.5	5	8	8	18	18						
100	200	3.5	3	4.5	5	10	8	20	18						
200	315	4	3.5	6	5	12	8	23	18	6	6	12	12	23	23
315	400	5	3.5	7	5	13	10	25	20	7	6	13	12	25	25
400	500	6	4	8	5	15	10	27	20	8	7	15	13	27	29
500	630	6	4	9	6	16	12	30	23	9	7	16	14	32	29
630	800	7	5	10	7	18	13	35	25	10	8	18	16	36	31
800	1000	8	6	11	8	21	15	40	27	11	9	21	17	40	34
1000	1250	9	6	13	9	24	16	46	30	13	10	24	19	47	39
1250	1600	11	7	15	10	29	18	54	35	15	11	29	22	55	44

Note (1): Travel variation in respect to the effective travelling distance of nut or to the effective length of threaded portion of screw shaft.

**Table 2. Travel variation (Permissible Values)**

Grade	C0		C1		C3		C5		G1		G3		G5	
Items	$V_{300}^{(2)}$	$V_{2\pi}^{(3)}$	$V_{300}^{(2)}$	$V_{2\pi}^{(3)}$	$V_{300}^{(2)}$	$V_{2\pi}^{(3)}$	$V_{300}^{(2)}$	$V_{2\pi}^{(3)}$	$V_{300}^{(2)}$	$V_{2\pi}^{(3)}$	$V_{300}^{(2)}$	$V_{2\pi}^{(3)}$	$V_{300}^{(2)}$	$V_{2\pi}^{(3)}$
Permissible value	3.5	3	5	4	8	6	18	8	6	4	12	6	23	8

Note (2) : Travel variation in respect to 300mm taken arbitrarily within the effective length of threaded portion of screw shaft.

(3) : Travel variation in respect to arbitrary revolution ( $2\pi$  rad) within the effective length of threaded portion of screw shaft.

## 2.3 Axial Clearance

Combination of Sanyo Precision Ball Screw of each grade with axial clearance is shown in Table 3.

**Table 3. Combination of Grade with Axial Clearance**

Axial clearance		Z		T		S		N	
		0 (Preload)		Not more than 0.005		Not more than 0.020		Not more than 0.050	
Grade									
C0	—	C0Z	—	C0T	—	—	—	—	—
C1	G1	C1Z	G1Z	C1T	G1T	—	—	—	—
C3	G3	C3Z	G3Z	C3T	G3T	C3S	G3S	—	—
C5	G5	C5Z	G5Z	C5T	G5T	C5S	G5S	C5N	G5N

# 2. ACCURACY

## 2.4 Preload Torque

Fig. 3. Terms of Preload Torque

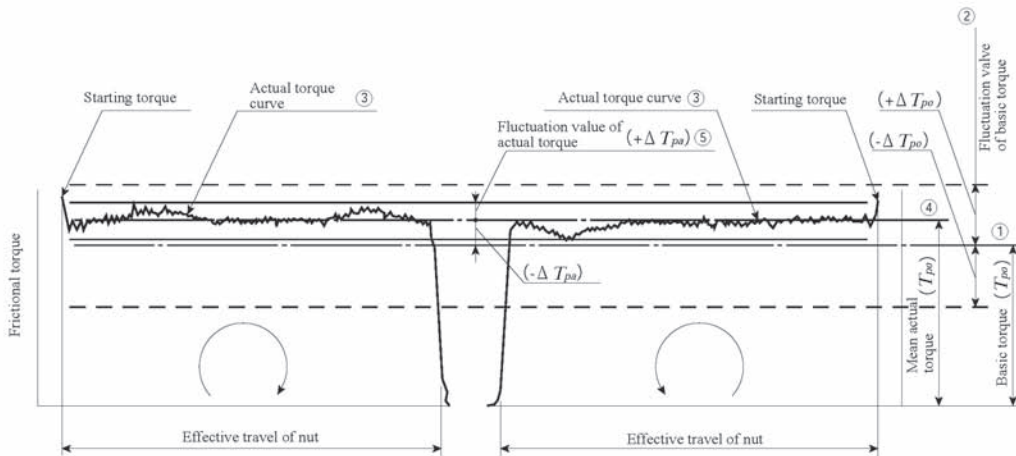

### 2.4.1. Terms and Definitions of Preload Torque

- (1) **Preload  $F_{pr}$**   
A force which is allowed to exert action in a ball screw, assembling a group of nuts, which have been displaced in an axial direction to each other, to attempt to decrease the backlash and to increase the rigidity of the ball screw.
- (2) **Dynamic drag torque  $T_p$**   
A dynamic torque required to rotate the nut against the screw shaft or the screw shaft against the nut, under the conditions of the ball screw which has been subjected to the prescribed preload in the absence of any external load and with the end seal removed.
- (3) **Total dynamic drag torque  $T_t$**   
A dynamic torque required to rotate the nut against the screw shaft or the screw shaft against the nut, under the conditions of the ball screw which has been subjected to the prescribed preload in the absence of any external load and with the end seal removed.
- (4) **Basic torque  $T_{po}$**   
Dynamic drag torque which has been established as a target. [① in Fig. 3]
- (5) **Fluctuation value of basic torque  $\Delta T_{po}$**   
Fluctuation value of dynamic drag torque which has been established as a target. It is taken as the positive and negative in respect to basic torque. [② in Fig. 3]
- (6) **Fluctuation rate of torque**  
Rate of basic torque fluctuation value  $\Delta T_{po}$  to basic torque  $T_{po}$ .
- (7) **Actual torque curve**  
Dynamic torque curve which has been measured on actual preload ball screw. [③ in Fig. 3]
- (8) **Mean actual torque  $T_{pa}$**   
Arithmetic mean value of maximum value and minimum value of actual torque (except starting torque) when measured allowing the nut to have reciprocating motion in respect to the effective length of the threaded portion. [④ in Fig. 3]
- (9) **Fluctuating value of actual torque  $\Delta T_{pa}$**   
Maximum fluctuation value of actual torque curve (except starting torque) when measured allowing the nut to have reciprocating motion in respect to the effective length of threaded portion. It is taken as the positive and negative in respect to mean actual torque. [⑤ in Fig. 3]
- (10) **Fluctuation rate of actual torque**  
Rate of mean actual torque  $\Delta T_{pa}$  to fluctuation value of actual torque  $T_{pa}$ .

**Table 4. Tolerance Zone of Fluctuation Rate of Torque**

Basic torque N · m		Slenderness <sup>(4)</sup> : 40 maximum				Slenderness <sup>(4)</sup> : 60 maximum			
		Grade				Grade			
Over	Not more than	C0	C1,G1	C3,G3	C5,G5	C0	C1,G1	C3,G3	C5,G5
0.2	0.4	± 30 %	± 35 %	± 40 %	± 50 %	± 40 %	± 40 %	± 50 %	± 60 %
0.4	0.6	± 25	± 30	± 35	± 40	± 35	± 35	± 40	± 45
0.6	1.0	± 20	± 25	± 30	± 35	± 30	± 30	± 35	± 40
1.0	2.5	± 15	± 20	± 25	± 30	± 25	± 25	± 30	± 35

Note (4) : Slenderness means the numerical value of effective length of threaded portion of the screw shaft divided by the nominal outside diameter of ball screw.

Remarks: Basic torque of not more than 0.2 is separately controlled by Sankyo Standard.

## 2.5 Accuracies on Supporting Part of Ball Screw

### 2.5.1 Accuracies on supporting part of C Series Ball Screws

Fig. 4 shows Accuracies on supporting part of ball screw. The respective accuracies and permissible values conform to JIS B 1192 (Ball Screws).

- (1) Circumferential runouts in radial direction of outside diameter of the supporting part of screw shaft in respect to axial line of screw groove surface.
- (2) Circumferential runouts in radial direction of outside diameter of the mounting part in respect to axial line of screw shaft.

- (3) Squareness of end face of supporting part in respect to axial line of supporting part of screw shaft.
- (4) Squareness of basic end face of nut or flange mounting surface in respect to axial line of screw shaft.
- (5) Circumferential runout in radial direction on outer peripheral face of nut (in case of cylindrical shape) in respect to axial line of screw shaft.
- (6) Parallelism of outer peripheral face of nut (in case of plane mounting surface) in respect to axial line of screw shaft.
- (7) Total radial runout on axial line of screw shaft.

**Fig. 4 Accuracies on Supporting Part of Ball Screw**

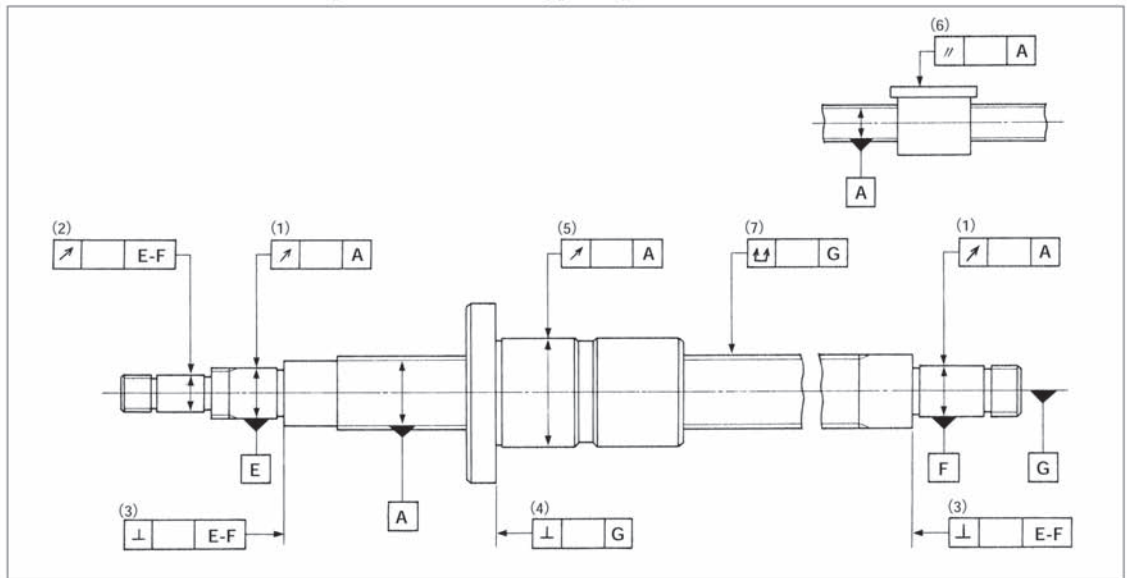

# 3. NOTATION OF SANKYO PRECISION BALL SCREWS

## Notation of Sankyo Precision Ball Screws

(Example)

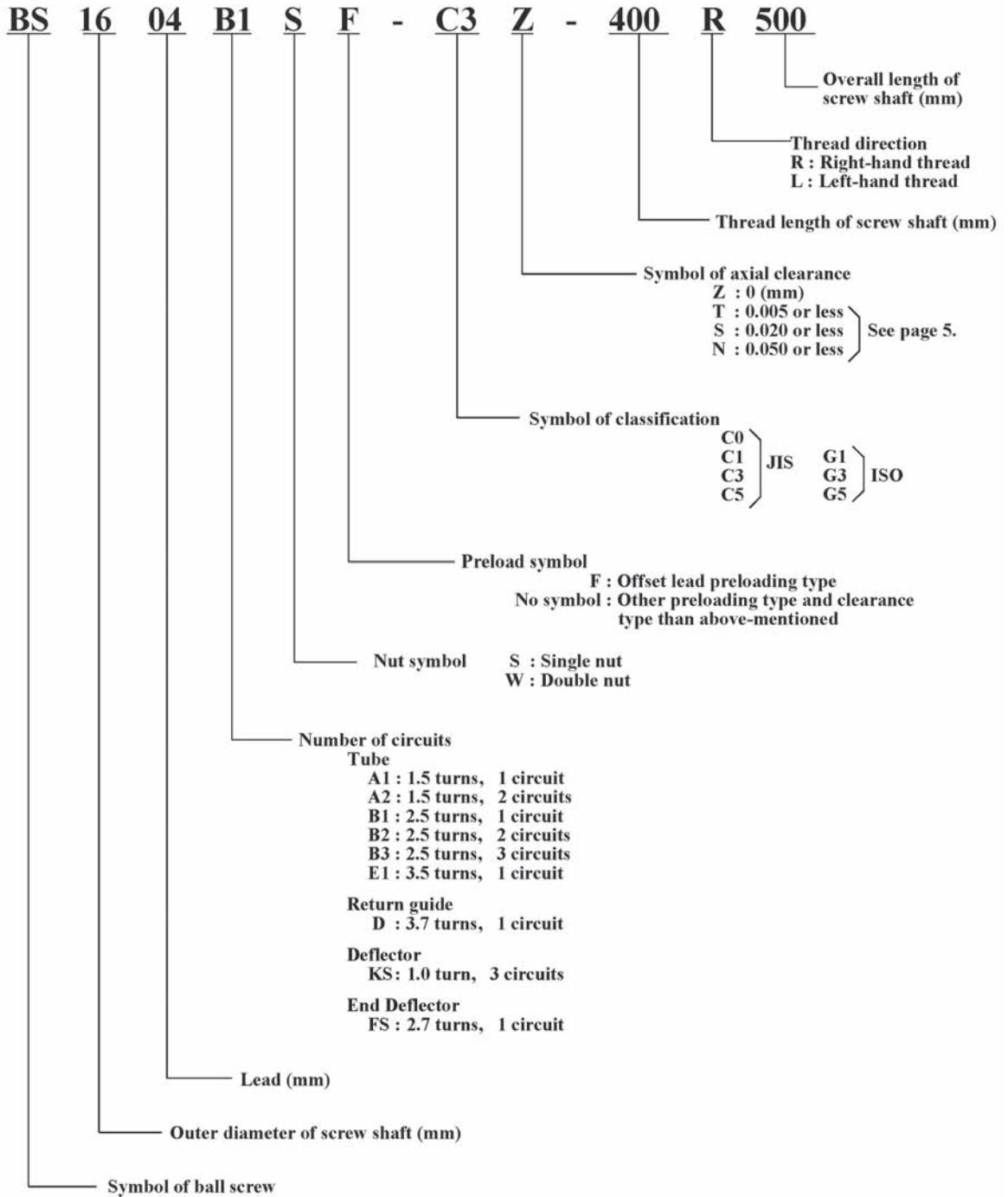



# 4. DESIGN OF SCREW SHAFTS

## 4.1 Combination of Nominal Outside Diameter and Lead of Screw Shaft

Table 5. Combination of Nominal Outside Diameter and Lead of Screw Shaft

Nominal O.D. of screw shaft (mm)	Lead (mm)														
	1	1.5	2	2.5	3	4	5	6	8	10	12	16	20	25	
3	○														
4	○														
5	○		○												
6	○	○	○												
8	○	○	○	○	○		○								
10	○	○	○	○	○	○	○		○	○					
12	○		○	○	○	○	○	○	○	○		○	○		
14	○		○	○	○	○	○		○	○			○		
15					○	○	○		○	○			○		
16	○		○	○	○	○	○	○				○			
18										○					
20			○		○	○	○	○		○	○		○	○	
25			○		○	○	○	○	○	○	○	○	○	○	
28					○		○	○	○	○	○				
32			○		○	○	○	○	○	○					
36					○	○	○	○	○	○					
40							○	○	○	○					

Note: Although combinations other than the half-tone circles are not given in Dimension Tables (Page 26 - 61), they are manufactured upon order.  
For your specific requirements other than these combinations, contact Sankyo.

# 4. DESIGN OF SCREW SHAFTS

## 4.2 Dimensional Ranges of Screw Shafts

Fig. 5 shows the dimensional ranges of screw shafts classified by their grades. For your specific requirements outside these ranges, contact our company.

Fig. 5 Dimensional ranges of screw shafts classified by their grades

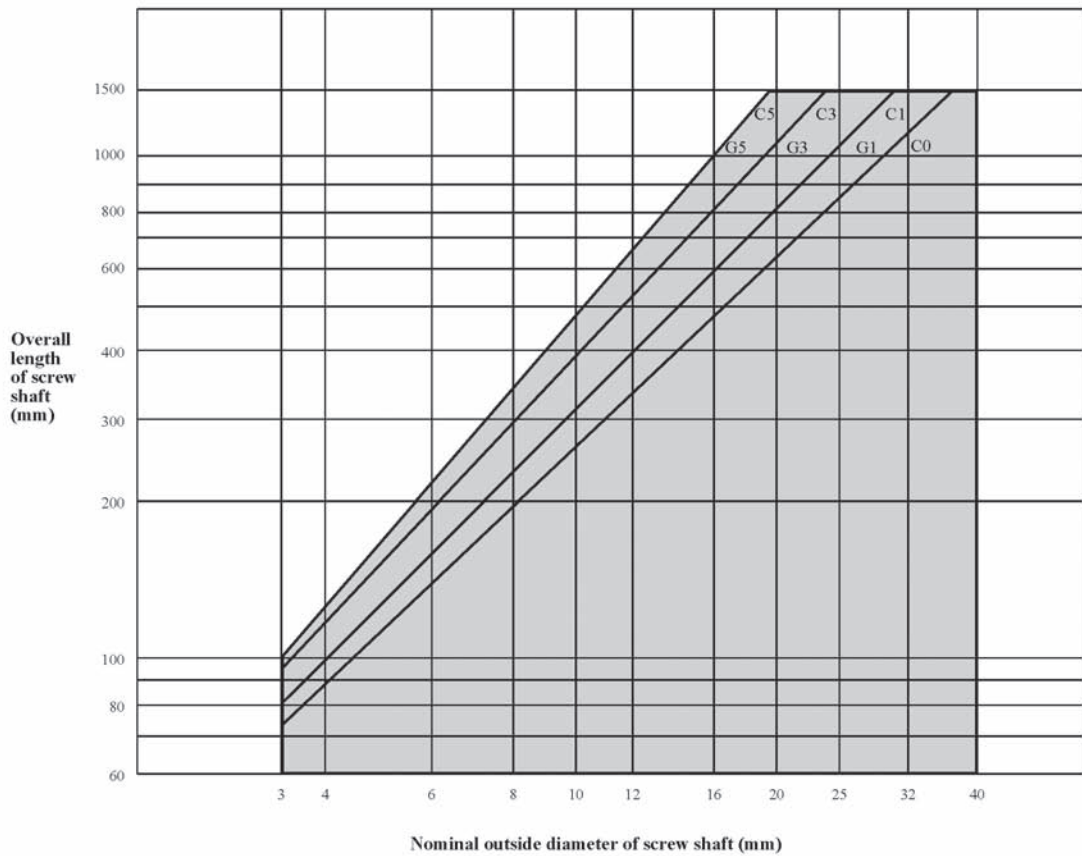

### 4.3 Supporting Method

Fig. 6 shows the typical method of supporting ball screws. When strict operating conditions of high degree of accuracy are required, careful consideration must be taken because the supporting method has a direct relation to permissible axial load and critical speed.

**Fig. 6 Typical mounting examples of screw shafts and nuts**

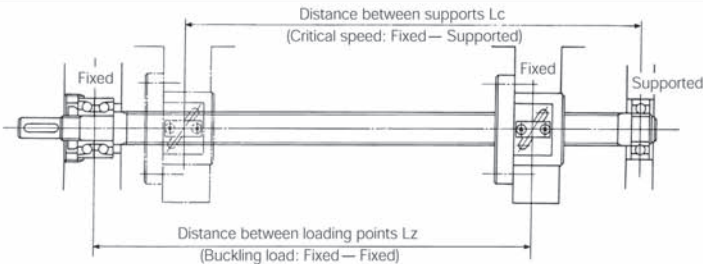
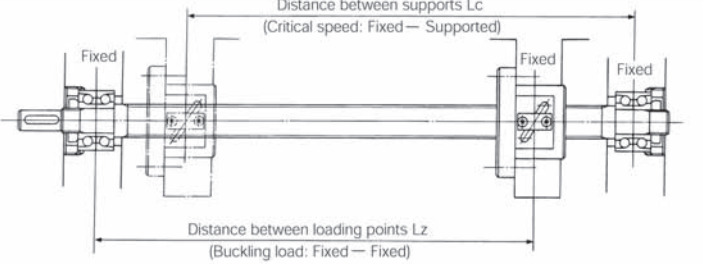
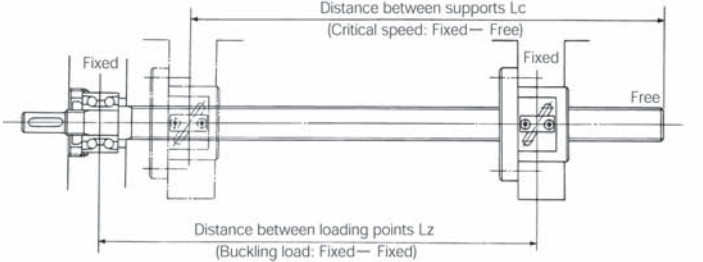
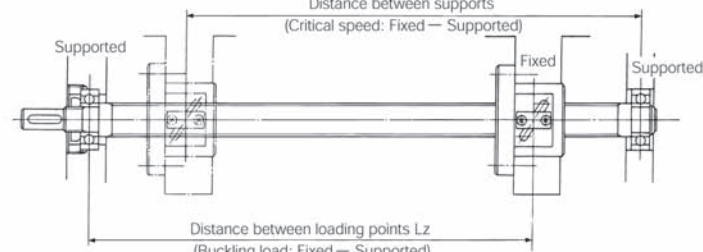
Supporting method	Main applications
 <p>Distance between supports <math>L_c</math> (Critical speed: Fixed — Supported)</p> <p>Distance between loading points <math>L_z</math> (Buckling load: Fixed — Fixed)</p>	<ul style="list-style-type: none"> <li>• Ordinary supporting method</li> <li>• Medium and highspeed revolution</li> <li>• High accuracy</li> </ul>
 <p>Distance between supports <math>L_c</math> (Critical speed: Fixed — Supported)</p> <p>Distance between loading points <math>L_z</math> (Buckling load: Fixed — Fixed)</p>	<ul style="list-style-type: none"> <li>• Highspeed revolution</li> <li>• High accuracy</li> </ul>
 <p>Distance between supports <math>L_c</math> (Critical speed: Fixed — Free)</p> <p>Distance between loading points <math>L_z</math> (Buckling load: Fixed — Fixed)</p>	<ul style="list-style-type: none"> <li>• Low speed revolution</li> <li>• Medium accuracy</li> <li>• For long shaft length</li> </ul>
 <p>Distance between supports <math>L_c</math> (Critical speed: Fixed — Supported)</p> <p>Distance between loading points <math>L_z</math> (Buckling load: Fixed — Supported)</p>	<ul style="list-style-type: none"> <li>• Medium speed revolution</li> <li>• Medium accuracy</li> </ul>

# 4. DESIGN OF SCREW SHAFTS

## 4.4 Permissible Axial Load

### (1) Buckling load (Oblique lines in Fig. 7)

When the screw shaft is subject to compression load, it is necessary to take measures to prevent buckling in accordance with the following equation.

$$P = \frac{n \cdot \pi^2 \cdot E \cdot I}{Lz^2} \times \alpha$$

Where P : Permissible axial load to buckling (N)  
 a : Safety factor (0.5)  
 Lz : Distance between loading points (mm)  
 (See Fig. 6.)  
 E : Modulus of longitudinal elasticity  
 ( $2.06 \times 10^5 \text{ N/mm}^2$ )  
 I : Minimum secondary moment of screw shaft  
 cross section ( $\text{mm}^4$ )

$$I = \frac{\pi}{64} dr^4$$

dr : Screw shaft root diameter (mm)  
 (See Dimension Table.)  
 n : Factor determined by supporting method of  
 ball screws  
 Both ends supported n=1  
 One end fixed other end supported n=2  
 Both ends fixed n=4  
 One end fixed other end free n=0.25

### (2) Permissible tensile compressive load (Perpendicular lines to permissible axial load scale marks)

When the distance between loading points is short, it is necessary to examine permissible tensile compressive load in accordance with the following equation independently of the supporting method.

Select a proper load on the "Both ends fixed" scale.

$$P = \sigma \cdot A$$

Where P : Permissible tensile compressive load (N)  
 $\sigma$  : Permissible stress ( $147 \text{ N/mm}^2$ )  
 A : Sectional area at screw shaft root diameter  
 ( $\text{mm}^2$ )

$$A = \frac{\pi}{4} dr^2$$

dr : Screw shaft root diameter (mm)  
 (See Dimension Table.)

(3) Parallel lines to the permissible axial load scale marks represent the maximum length of screw shafts that can be manufactured in the standard operation for the nominal screw shaft outside diameter. As the screw shaft length is limited by the grade, refer to Fig. 5 (Page 8).

Fig. 7 Permissible axial load lines

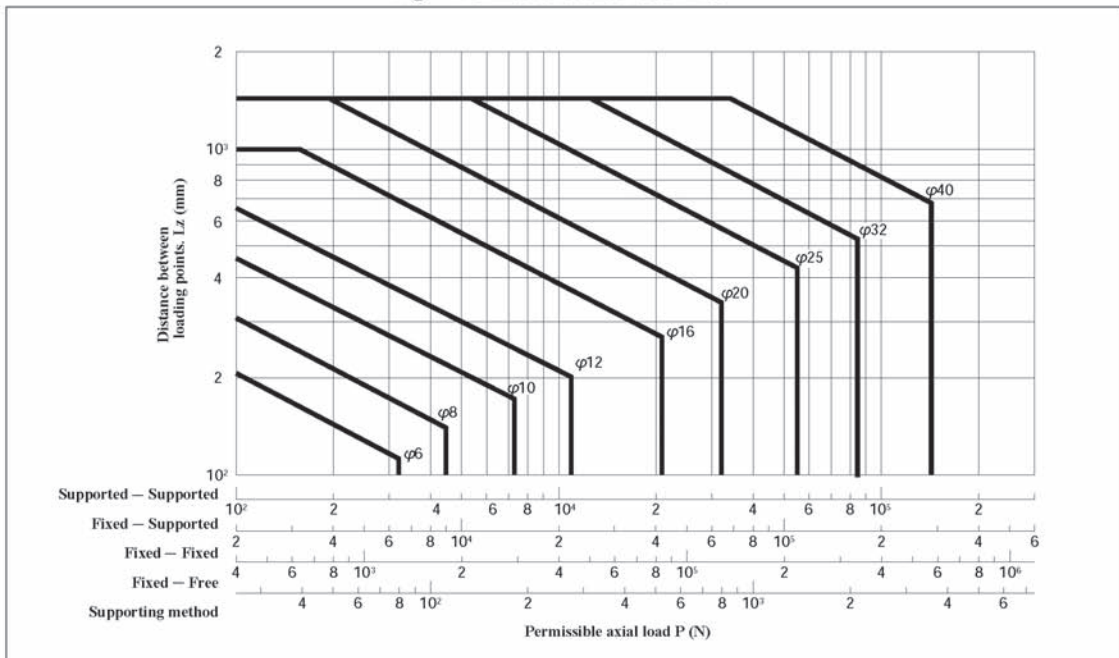

## 4.5 Permissible Operating Speed

### (1) Critical speed (Oblique lines in Fig. 8)

It is necessary to examine critical speed so that the number of revolutions of the ball screw may not resonate with the natural frequency of the screw shaft.

$$N = \frac{60 \lambda^2}{2 \pi \cdot Lc^2} \sqrt{\frac{E \cdot I \cdot g}{\gamma \cdot A}} \times \alpha$$

Where N : Permissible operating speed for critical speed (rpm)  
 $\alpha$  : Safety factor (0.8)  
 Lc : Distance between supports (mm)  
 (See Fig. 6.)  
 E : Modulus of longitudinal elasticity  
 ( $2.06 \times 10^5 \text{ N/mm}^2$ )  
 I : Minimum secondary moment of screw shaft cross section ( $\text{mm}^4$ )

$$I = \frac{\pi}{64} dr^4$$

dr : Screw shaft root diameter (mm)  
 (See Dimension Table.)  
 g : Acceleration of gravity  
 ( $9.8 \times 10^3 \text{ mm/sec}^2$ )  
 $\gamma$  : Specific gravity ( $7.7 \times 10^5 \text{ N/mm}^3$ )  
 A : Sectional area at screw shaft root diameter ( $\text{mm}^2$ )

$$A = \frac{\pi}{4} dr^2$$

$\lambda$  : Factor determined by supporting method of ball screws  
 Both ends supported  $\lambda = \pi$   
 One end fixed other end supported  $\lambda = 3.927$   
 Both ends fixed  $\lambda = 4.730$   
 One end fixed other end free  $\lambda = 1.875$

(2) **Dm · N value** (Perpendicular lines to permissible operating speed)  
 The critical speed is also limited by Dm · N value that is the limit of the peripheral speed of a ball screw. Select a proper load value on the "Both ends fixed" scale.

$$Dm \cdot N \leq 70,000$$

Where Dm : Ball circle dia. (BCD)  
 N : Number of revolutions (rpm)

(3) Parallel lines to the permissible operating speed represent the maximum length of screw shafts that can be manufactured in the standard operation for the nominal screw shaft outside diameter. As the screw shaft length is limited by the grade, refer to Fig. 5 (Page 8).

Fig. 8 Permissible operating speed lines

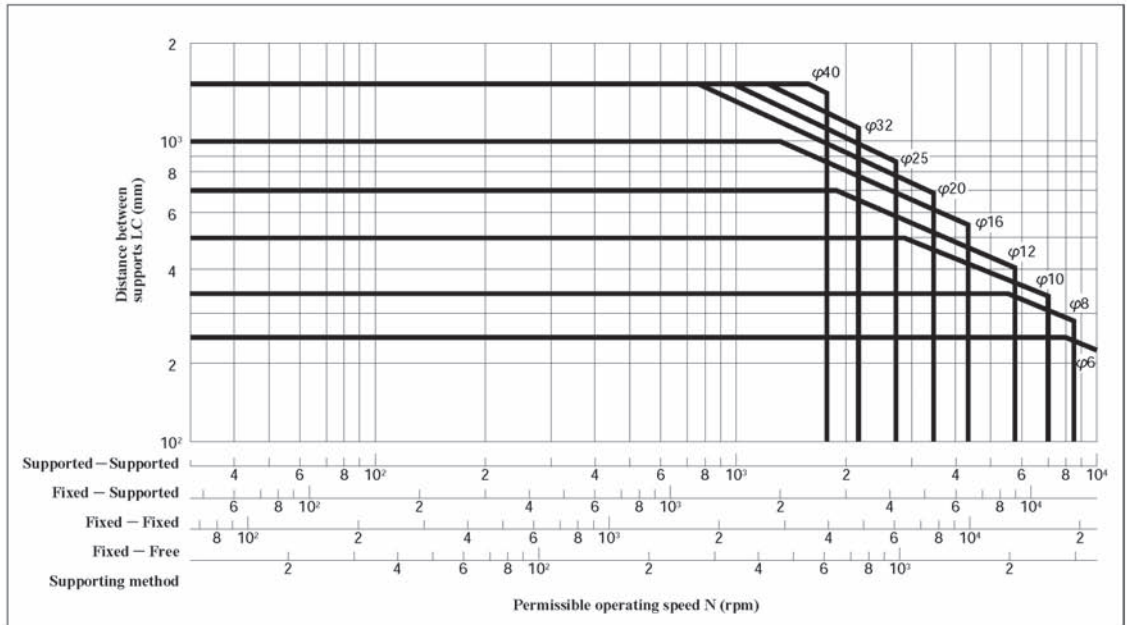

# 4. DESIGN OF SCREW SHAFTS

## 4.6 Hints on Designing a Screw Shaft

### (1) Mounting

When mounting a ball screw, it is not advisable to select such a construction that the screw shaft has to be disconnected from the nut. If the screw shaft is disconnected from the nut, the steel ball may come off, the nut position accuracy and preload amount may fluctuate and the steel ball circulating part may be broken. When it is unavoidably necessary to employ such a construction, supply us with a part mountable between the screw shaft and the nut. We will fit the part to the ball screw in our factory before shipment.

When disconnecting the screw shaft from the nut in an unavoidable case, use a sleeve as shown in Fig. 9 to disconnect the screw shaft with the steel ball housed in the nut. In this case, the sleeve outside diameter should be less than the screw shaft root diameter by 0.2 – 0.4mm (refer to the dimension table).

### (3) Treatment of screw shaft end

When it is necessary to dowel the screw shaft after it is received, specify the position and size of the dowel pin. The product will be shipped with the specified portion unhardened for ease of post-treatment.

Fig. 9 Nut removing sleeve

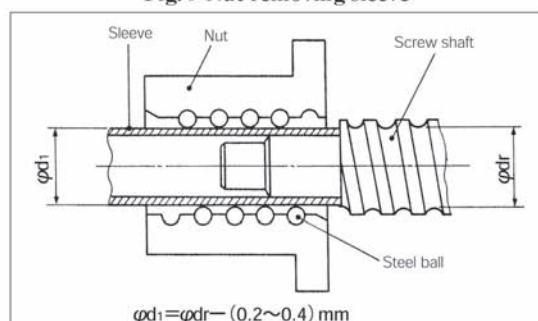

### (2) Configuration of screw shaft end

When designing a configuration for the screw shaft end, reduce the diameter of one end of the shaft to less than the screw shaft root diameter (refer to the dimension table.) and completely thread to the shaft end.

Assembling of the return guide type ball screw is structurally impossible.

Fig. 10 Screw shaft end configuration

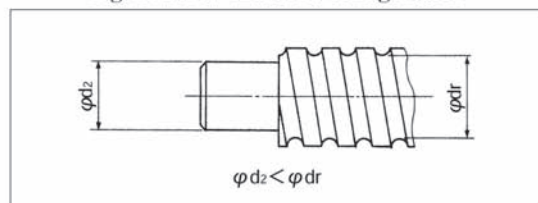

# 5. DESIGN OF NUTS

## 5.1 Structure of nut

The circuit system of ball screw is divided into "outer side circuit system" and "internal side circuit system".

Outer side circuit system: tube type, return guide type

Internal side circuit system: deflector type, end deflector type

### (1) Tube type

The steel balls are picked up at the tip of U-shaped tube and rotate inside tube, then return back to screw groove.

**Fig. 11-a Tube type**

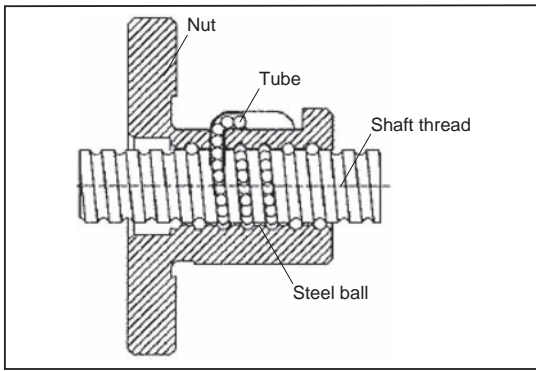

Feature: Available for short to long lead

### (2) Return guide type

The steel balls are picked up at the tip of deflector which is put inside nut and rotate through return guide, then come back to screw groove.

**Fig. 11-b Return guide type**

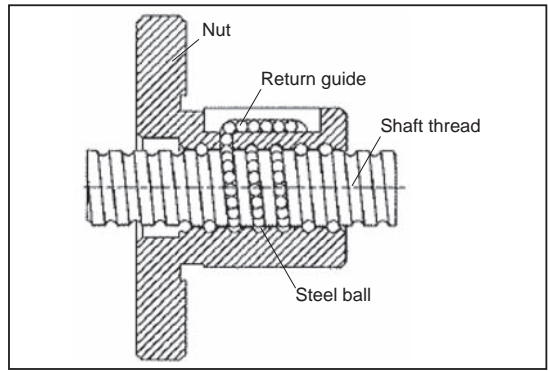

Feature: Available for short lead

### (3) Deflector type

The steel balls rotate through the deflector which is put inside nut. The steel balls circulate in just one lead.

**Fig. 12-a Deflector type**

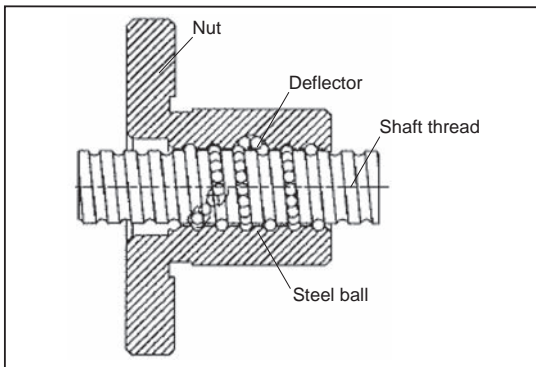

Feature: Available for compact size nut diameter  
Good balance of rotation

### (4) End deflector type

The steel balls circulate through the end deflector which is put inside both end of the nut. The steel balls rotate inside through hole of nut and return back to screw groove via deflector located opposite side.

**Fig. 12-b End deflector type**

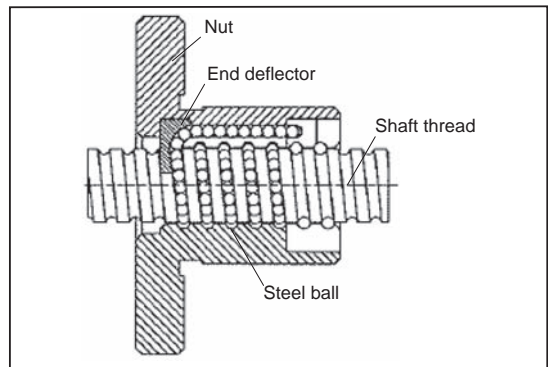

Feature: Available for high speed application  
Suitable for demand of low-sound rotation

# 5. DESIGN OF NUTS

## 5.2 Hints of Designing the Nut Associated Parts

### (1) Unbalanced load

A ball screw is designed to work most effectively when load to the steel ball that rolls between the screw shaft and nut is uniformly distributed. If unbalanced load is applied to the nut, concentrated load is applied to some steel balls, adversely affecting the operating performance and life. So, special care should be taken to the design and assembly of equipment.

**Fig. 13 Unbalanced load**

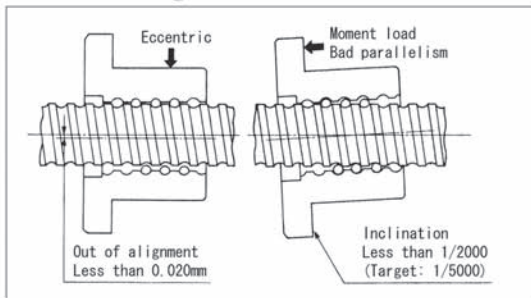

### (2) Mounting direction of return guide type nut

A return guide type ball screw should be mounted so that the return guide comes to the upside because of the construction of the steel ball circulating part. As a result, smooth rotation can be obtained.

**Fig. 14 Mounting direction of return guide type nut**

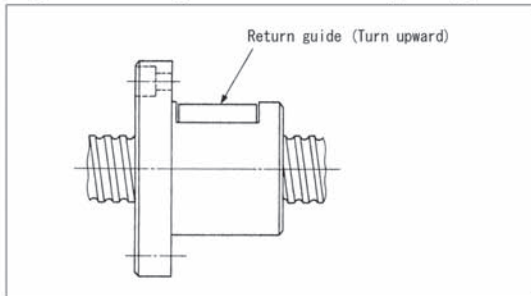



# 6. DESIGN FOR ACCURACY

## 6.1 Rigidity of Feed Screw System

When accurate positioning is required for an automatic control machine or precision instrument incorporating a feed mechanism, the axial rigidity of each component of the feed screw system should be thoroughly examined.

### 6.1.1 Axial rigidity of feed screw system

#### (1) Axial rigidity of feed screw system: $K_T$

The axial rigidity of the feed screw system can be obtained from the following equation.

$$K_T = \frac{Fa}{\delta}$$

$$\frac{1}{K_T} = \frac{1}{K_S} + \frac{1}{K_N} + \frac{1}{K_B} + \frac{1}{K_H}$$

Where  $K_T$ : Axial rigidity of feed screw system ( $N/\mu m$ )  
 $Fa$ : Axial load to feed screw system (N)  
 $\delta$ : Axial elastic displacement of feed screw system ( $\mu m$ )  
 $K_S$ : Axial rigidity of screw shaft ( $N/\mu m$ )  
 $K_N$ : Axial rigidity of nut ( $N/\mu m$ )  
 $K_B$ : Axial rigidity of support bearing ( $N/\mu m$ )  
 $K_H$ : Axial rigidity of nut and bearing mount ( $N/\mu m$ )

#### (2) Axial rigidity of screw shaft: $K_S$

(a) When "Both ends fixed" supporting method is not used:

$$K_S = \frac{A \cdot E}{L_z} \times 10^{-3}$$

Where  $K_S$ : Axial rigidity of screw shaft ( $N/\mu m$ )  
 $A$ : Sectional area of screw shaft ( $mm^2$ )

$$A = \frac{\pi}{4} dr^2$$

$dr$ : Screw shaft root diameter (mm)  
 (See Dimension Table)  
 $E$ : Modulus of longitudinal elasticity ( $2.06 \times 10^5 N/mm^2$ )  
 $L_z$ : Distance between loading points (mm)

**Fig. 15** When "Both ends fixed" supporting method is not used:

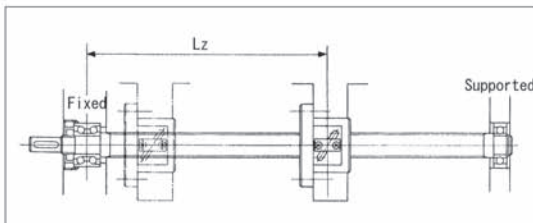

(b) When "Both ends fixed" supporting method is used:

$$K_S = \frac{A \cdot E \cdot L}{L_z(L - L_z)} \times 10^{-3}$$

Where  $K_S$ : Axial rigidity of screw shaft ( $N/\mu m$ )  
 $L$ : Distance between supports (mm)

**Fig. 16** When "Both ends fixed" supporting method is used:

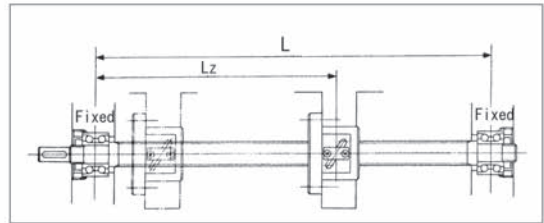

(Note) Screw shaft displacement by axial load

(a) When "Both ends fixed" supporting method is used:

$$\delta_L = \frac{Fa}{K_S} = \frac{Fa \cdot L_z}{A \cdot E} \times 10^3$$

Where  $\delta_L$ : Displacement by axial load ( $\mu m$ )

(b) When "Both ends fixed" supporting method is not used:

$$\delta_L = \frac{Fa}{K_S} = \frac{Fa}{A \cdot E} \left(1 - \frac{L_z}{L}\right) L_z \times 10^3$$

Where  $\delta_L$ : Displacement by axial load ( $\mu m$ )

When "Both ends fixed" supporting method is used, the axial displacement maximizes at position  $L_z = L/2$ .

$$\left(\delta_L = \frac{Fa \cdot L}{4A \cdot E} \times 10^3\right)$$

Consequently, the maximum axial displacement for a case of "Both ends fixed" supporting method is reduced to 1/4 as compared with a case other than "Both ends fixed" supporting method.

# 6. DESIGN FOR ACCURACY

### (3) Rigidity of nut: $K_N$

#### (a) Rigidity of clearance ball screw

Dimension Table gives theoretical rigidity  $K$  obtained from elastic displacement between the thread groove and steel ball when axial load equivalent to 30% of basic dynamic load rating  $C_a$  is applied. Taking into consideration the nut, use of 80% of each value shown in the Table as a general rule. When axial load  $F_a$  differs from  $0.3C_a$ , rigidity  $K_N$  can be obtained from the following equation.

$$K_N = 0.8 \times K \left( \frac{F_a}{0.3C_a} \right)^{1/3} \text{ (N/}\mu\text{m)}$$

Where  $K$  : Rigidity in Dimension Table (N/ $\mu$ m)  
 $F_a$  : Axial load (N)  
 $C_a$  : Basic dynamic load rating (N)

#### (b) Rigidity of preloaded ball screw

Dimension Table gives theoretical rigidity  $K$  obtained from elastic displacement between the thread groove and steel ball when axial load equivalent to 10% (5% for oversize ball preloading type) of basic dynamic load rating is applied. Taking into consideration the nut, use of 80% of each value shown in the Table as a general rule. When axial load  $F_{a0}$  differs from  $0.1C_a$  ( $0.05C_a$ ), rigidity  $K_N$  can be obtained from the following equation.

$$K_N = 0.8 \times K \left( \frac{F_{a0}}{\varepsilon C_a} \right)^{1/3} \text{ (N/}\mu\text{m)}$$

Where  $K$  : Rigidity in Dimension Table (N/ $\mu$ m)  
 $F_{a0}$  : Preload (N)  
 $\varepsilon$  : Basic coefficient for calculating rigidity  
 $\varepsilon = 0.10$   
 $\varepsilon = 0.05$  (Oversize ball preload)

### (4) Rigidity of support bearing: $K_B$

Rigidity is determined according to the type of bearing used (ball bearing, roller bearing), preload amount, etc. Rigidity  $K_B$  with roller bearing preloaded is obtained from the following equation.

$$K_B = \frac{3F_{a0}}{\delta_{a0}} \text{ (N/}\mu\text{m)}$$

Where  $F_{a0}$  : Preload (N)  
 $\delta_{a0}$  : Axial elastic displacement for preload ( $\mu$ m)  
 Provided  $0 < \text{Axial external load} \leq 3F_{a0}$

#### (a) Axial elastic displacement of thrust angular ball bearing (for supporting ball screw) and angular ball bearing

$$\delta_a = \frac{2}{\sin \alpha} \left( \frac{Q^2}{D_a} \right)^{1/3} \quad Q = \frac{F_a}{Z \cdot \sin \alpha}$$

#### (b) Axial elastic displacement of tapered roller bearing

$$\delta_a = \frac{0.6}{\sin \alpha} \times \frac{Q^{0.9}}{\ell a^{0.8}} \quad Q = \frac{F_a}{Z \cdot \sin \alpha}$$

#### (c) Axial elastic displacement of thrust ball bearing

$$\delta_a = 2.4 \left( \frac{Q^2}{D_a} \right)^{1/3} \quad Q = \frac{F_a}{Z}$$

Where  $\delta_a$  : Axial elastic displacement ( $\mu$ m)  
 $\alpha$  : Contact angle  
 $Q$  : Load per rolling element (N)  
 $D_a$  : Steel ball diameter (mm)  
 $\ell a$  : Effective contact length of roller (mm)  
 $F_a$  : Axial load (N)  
 $Z$  : Number of rolling element

### (5) Rigidity of mounting part of nut and bearing: $K_H$

When designing a feed unit, try to provide high rigidity for the mounting part.

### 6.1.2 Torsional strength of screw shaft

Angle of torsion that will be produced by twisting moment of the screw shaft can be obtained from the following equation.

$$\theta = \frac{32T \cdot L}{\pi \cdot G \cdot dr^4} \times \frac{360}{2\pi} = 7.21 \times 10^{-2} \frac{T \cdot L}{dr^4}$$

Where  $\theta$  : Angle of torsion (degree)  
 $T$  : Twisting moment (N $\cdot$ mm)  
 $L$  : Distance between torsional points (mm)  
 $G$  : Modulus of traverse elasticity ( $7.9 \times 10^4$  N/mm)  
 $dr$  : Screw shaft root diameter (mm)  
 (See Dimension Table.)

Lag  $\Delta$  of axial movement by angle of torsion can be obtained from the following equation:

$$\Delta = \ell \times \frac{\theta}{360} \times 10^3 \text{ (}\mu\text{m)}$$

Where  $\ell$  : Lead of ball screw (mm)

### 6.1.3 Preload of Ball Screws

When extremely accurate positioning is required, it is usual to preload the ball screw to increase the rigidity so that elastic displacement to the axial load may be minimized with the axial clearance of the ball screw zeroed.

#### (1) Preloading

##### (a) Double nut preloading (Spacer preloading)

In this type, a spacer is inserted between two nuts to achieve correct preload. There are two methods of preloading. One method is called "Tension preloading" by which a thick spacer with a thickness equivalent to the amount of preload is inserted between the nuts to obtain correct preload as shown in Fig. 17.

Sanjyo precision ball screws use the "Tension preloading" as a standard method of preloading.

**Fig. 17 Tension preloading**

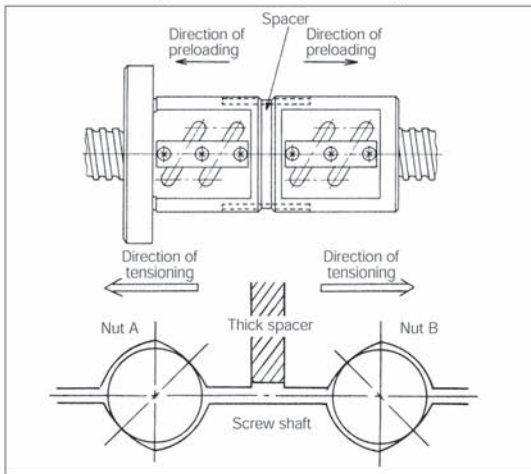

Another method of preloading is to insert a thin spacer with a thickness equivalent to the amount of preload between the nuts to obtain correct preload. It is called "Compression preloading".

##### (b) Single nut preloading (Oversize ball preloading)

In this type, preload is applied by using one nut. As shown in Fig. 18, a steel ball (Oversize ball) which is slightly larger than the clearance in the thread groove is inserted and brought into contact at four points to attain correct preload.

**Fig. 18 Oversize ball preloading**

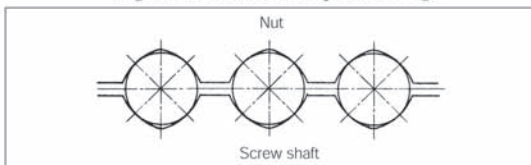

In order to improve the working efficiency, a spacer ball (1:1) is generally used. (Fig. 19)

**Fig. 19 Spacer ball**

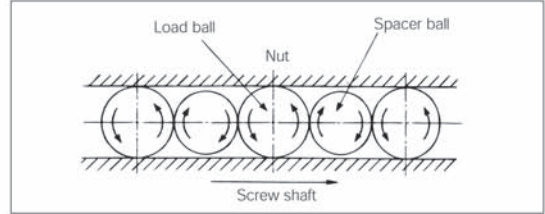

##### (c) Single nut preloading (Offset ball preloading)

In this type, preload is applied by using one nut. As shown in Fig. 20, the lead at the center of the nut is enlarged by an amount of preload  $a$  for preloading.

**Fig. 20 Offset lead preloading**

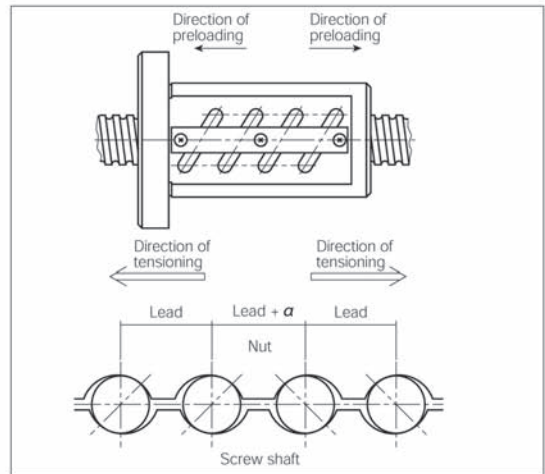

#### (2) Axial elastic deformation

When a ball screw receives axial load, the steel ball and the thread groove surface will deform. The relationship between the amount of axial elastic deformation  $\delta a$  and the axial load  $Fa$  is calculated from Herz's point contact theory similarly to ball bearings.

$$\delta a \propto Fa^{2/3}$$

##### (a) Axial elastic deformation of single nut (Non-preload): $\delta a$

$$\delta a = \frac{2.6}{\sin \alpha} \left( \frac{Q^2}{Da} \right)^{1/3} \times \xi \quad (\mu m)$$

Where  $\alpha$  : Contact angle of steel ball with thread groove ( $45^\circ$ )

$Da$  : Steel ball diameter (mm)

$Q$  : Load per steel ball (N)

$$Q = Fa/Z \cdot \sin \alpha$$

$Z$  : Number of steel balls

$\xi$  : Coefficient for accuracy and construction

# 6. DESIGN FOR ACCURACY

(b) Axial elastic deformation of preloaded ball screw

**Fig. 21 Double nut preloading**

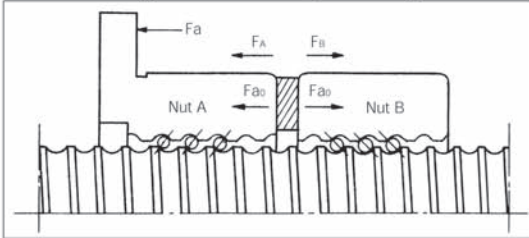

As shown in Fig. 21, preload  $F_{a0}$  is applied to nuts A and B, both nuts will be elastically deformed up to point X. When external force  $F_a$  is exerted in this state, nut A shifts from point X to point  $X_1$  and nut B from point X to point  $X_2$ . (Fig. 22)

Assuming that proportional constant is  $k$ , formula  $\delta_a \propto F_a^{2/3}$  gives the following equation:

$$\delta_{a0} = k \cdot F_{a0}^{2/3}$$

The amount of deformation of nuts A and B is as follows:

$$\delta_A = k \cdot F_A^{2/3}$$

$$\delta_B = k \cdot F_B^{2/3}$$

Because the amount of deformation of nut A by the external force  $F_a$  is equal to that of nut B, the following equation is formed:

$$\delta_A - \delta_{a0} = \delta_{a0} - \delta_B$$

In addition, the external force applied to nut A and B is  $F_a$  alone. Therefore,

$$F_A - F_B = F_a$$

According as  $F_A$  increases, the external force applied to nut B is reduced by the absorption of nut A until  $\delta_B=0$ .

As a result, where  $\delta_B=0$

$$k \cdot F_A^{2/3} - k \cdot F_{a0}^{2/3} = k \cdot F_{a0}^{2/3}$$

$$F_A^{2/3} = 2F_{a0}^{2/3}$$

$$F_A = \sqrt[3]{8} F_{a0} \approx 3F_{a0}$$

Also, from the equation  $\delta_A - \delta_{a0} = \delta_{a0}$ , the following equation is formed:

$$\delta_{a0} = \frac{1}{2} \delta_A$$

Consequently, when axial load is three times as much as the amount of preload, the amount of deformation on the preloaded ball screw becomes half as much as that of a non-preloaded ball screw, while the rigidity doubles. (See Fig. 23.)

$$K = \frac{F_a}{\delta_{a0}} = \frac{3F_{a0}}{0.5 \delta_a}$$

Where  $K$  : Rigidity (N/ $\mu$ m)

$F_a$  : Axial load (N)

$\delta_{a0}$  : Axial elastic deformation of preloaded ball screw ( $\mu$ m)

$F_{a0}$  : Preload (N)

$\delta_a$  : Axial elastic deformation of non-preload ball screw ( $\mu$ m)

**Fig. 22 Preload lines**

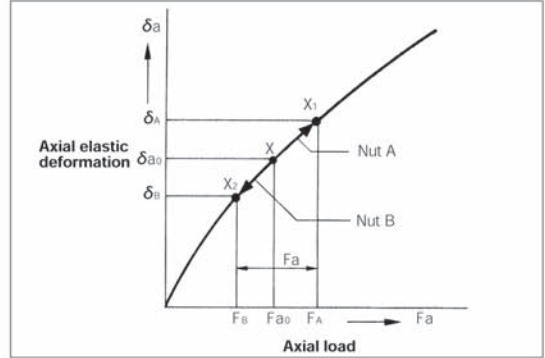

**Fig. 23 Axial elastic deformation curves**

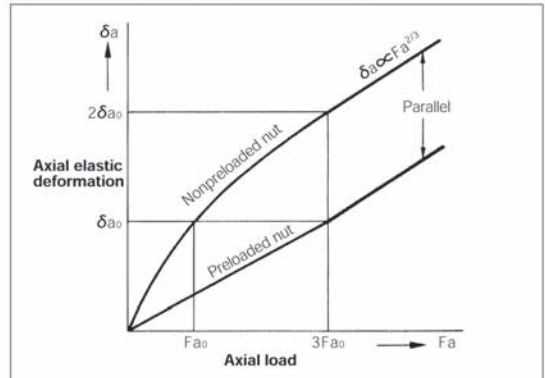

### (3) Preload setting

Recommendable preload is about 1/3 of the maximum axial load. Since excessive preload results in heating and adversely affects the service life, set the maximum preload at 10% of basic dynamic load rating  $C_a$  as a general rule.

Table 6 shows standard preload.

**Table 6. Standard Preload**

Classification	Unit: N	
	Light preload	Medium and heavy preload
Preload	Less than 0.05 $C_a$	Over 0.05 to 0.10 $C_a$

# 7. DESIGN OF RATED LIFE

## 7.1 Life of Ball Screw

The life of a ball screw is classified into fatigue life caused by flaking and wear life resulting in the deterioration of accuracy.

## 7.2 Fatigue Life

The fatigue life can be estimated by using the basic rated dynamic load as in the case of rolling bearings.

### 7.2.1 Basic rated dynamic load: Ca

The basic rated dynamic load is an axial load at which, when a group of the same ball screws are revolved under the same condition, more than 90% of these ball screws can reach the rated life of 1,000,000 revolutions without flaking. The basic rated dynamic load is given in Dimension Tables.

### 7.2.2 Fatigue Life

#### (1) Calculating the life

Fatigue life is generally expressed by a total number of revolutions, but it is sometimes expressed by total revolution time or total travel distance. Fatigue life can be calculated from the following formula:

$$L = \left( \frac{Ca}{Fa \cdot fw} \right)^3 \times 10^6$$

$$Lt = \frac{L}{60n}$$

$$Ls = \frac{L \cdot r}{10^6}$$

Where L : Rated fatigue life (rev)  
 Lt : Life time (hr)  
 Ls : Life in travel distance (km)  
 Ca : Basic rated dynamic load (N)  
 Fa : Axial load (N)  
 n : Number of revolutions (rpm)  
 r : Lead (mm)  
 fw : Load factor  
 (Classified by operating conditions)

Shockless smooth operation	1.0 — 1.2
Ordinary operation	1.2 — 1.5
Vibratory operation	1.5 — 3.0

#### (2) Average load

(a) When load and number of revolutions are classified by stages (Fig. 24):

Axial load (N)	Number of revolutions (rpm)	Operating time or operating time ratio
F <sub>1</sub>	n <sub>1</sub>	f <sub>1</sub>
F <sub>2</sub>	n <sub>2</sub>	f <sub>2</sub>
⋮	⋮	⋮
F <sub>n</sub>	n <sub>n</sub>	f <sub>n</sub>

Average load F<sub>m</sub> can be calculated from the following formula:

$$F_m = \left( \frac{F_1^3 \cdot n_1 \cdot t_1 + F_2^3 \cdot n_2 \cdot t_2 + \dots + F_n^3 \cdot n_n \cdot t_n}{n_1 \cdot t_1 + n_2 \cdot t_2 + \dots + n_n \cdot t_n} \right)^{1/3} \text{ (N)}$$

Average number of revolutions N<sub>m</sub> can be calculated from the following formula:

$$N_m = \frac{n_1 \cdot t_1 + n_2 \cdot t_2 + \dots + n_n \cdot t_n}{t_1 + t_2 + \dots + t_n} \text{ (rpm)}$$

Fig. 24 Warying load by stages

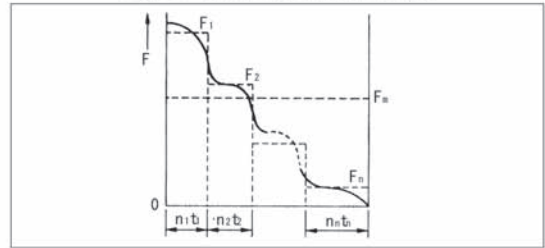

(b) When load varies almost linearly (Fig. 25): Average load F<sub>m</sub> can be proximately calculated from the following formula:

$$F_m = \frac{1}{3} (F_{min} + 2F_{max}) \text{ (N)}$$

Where F<sub>min</sub> : Minimum axial load (N)  
 F<sub>max</sub> : Maximum axial load (N)

Fig. 25 Monotonously varying load

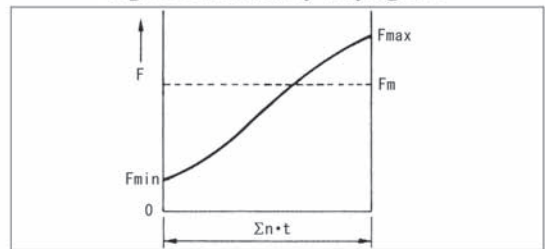

(c) When load varies drawing a sine curve (Fig. 26): Average load F<sub>m</sub> can be calculated from the following formula:

$$F_m \approx 0.65F_{max} \text{ (N) for (a) in Fig. 26}$$

$$F_m \approx 0.75F_{max} \text{ (N) for (b) in Fig. 26}$$

Fig. 26 Varying load drawing a sine curve

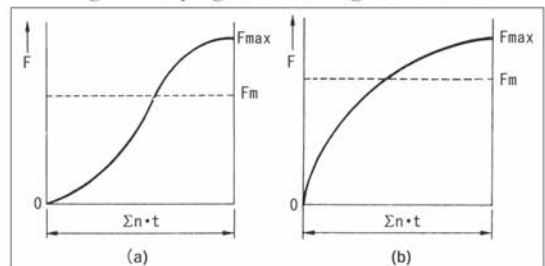

# 7. DESIGN OF RATED LIFE

## 7.2.3 Standard Life Time

If you request a long fatigue life unnecessarily when selecting a ball screw, you would get a large ball screw, resulting in poor economy. Some case examples of standard life requirements are given below for reference.

Machine tools.....	20,000 hours
Industrial machinery .....	10,000 hours
Automated control equipment .....	15,000 hours
Measuring instruments.....	15,000 hours

## 7.3 Permissible Load to Thread Groove

Even when a ball screw is not frequently used or is operated at low speed or other reasonable conditions meeting the fatigue life, it is necessary to select a ball screw so that the maximum axial load may be lower than the basic rated static load.

### 7.3.1 Basic Rated Static Load: $C_{0a}$

The basic rated static load is an axial static load under which the sum of permanent deformations of the following three factors may be equal to 0.01% of the steel ball diameter.

- Contact area of thread groove of screw shaft receiving the maximum stress.
- Contact area of thread groove of nut receiving the maximum stress.
- Steel ball receiving the maximum stress.

### 7.3.2 Permissible Load

The maximum permissible load  $F_{max}$  can be calculated from the following formula:

$$F_{max} = C_{0a}/f_s \text{ (N)}$$

Where  $C_{0a}$  : Basic rated static load (N)  
 $f_s$  : Safety factor  
 (Classified by operating conditions)

Ordinary operation	1 — 2
Vibratory operation	2 — 3

## 7.4 Materials and Harness

### 7.4.1 Standard Materials

Table 7. Materials and Hardness

Part name	Material	Heat-treatment	Hardness
Screw shaft Nut	SCM415H	Carburizing	HrC58-62

\*Ball screws made of special materials such as stainless steel for specific environment applications (SUS440C, SUS630) are manufactured upon order. We accept an order of surface-treatment.

### 7.4.2 Hardness Factor

When some material other than the standard materials shown in Table 9 with surface hardness of less than HrC58 is used, it is necessary to correct the basic rated dynamic load ( $C_a$ ) and basic rated static load ( $C_{0a}$ ). Correct  $C_a$  and  $C_{0a}$  values shown in Dimension Table by using the following formula:

$$C_a' = f_H \cdot C_a \text{ (N)}$$

$$C_{0a}' = f_{H'} \cdot C_{0a} \text{ (N)}$$

Where  $f_H$  : Hardness factor  
 $f_{H'}$  : Static hardness factor

Fig. 27 Hardness factor

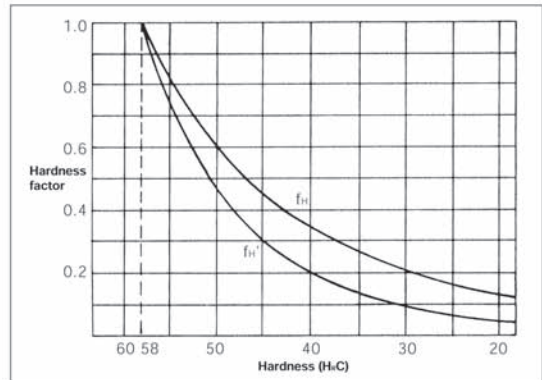

# 8. DRIVING TORQUE

## 8.1 Torque of Ball Screw

### (1) Normal operation

When rotation is converted into linear motion (Normal operation), the torque can be obtained from the following formula:

$$T_a = \frac{F_a \cdot R}{2 \pi \cdot \eta_1} \times 10^{-3}$$

Where  $T_a$  : Normal operation torque (N·m)  
 $F_a$  : Axial load (N)  
 $r$  : Lead (mm)  
 $\eta_1$  : Normal efficiency (0.9 — 0.95)

### (2) Reverse operation

When linear motion is converted into rotation (Reverse operation), the torque can be obtained from the following formula:

$$T_b = \frac{F_a \cdot R \cdot \eta_2}{2 \pi} \times 10^{-3}$$

Where  $T_b$  : Reverse operation torque (N·m)  
 $\eta_2$  : Reverse efficiency (0.85 — 0.9)

### (3) Preload torque

Basic torque of preloaded ball screw can be obtained from the following formula:

$$T_p = 0.05 (\tan \beta)^{-0.5} \frac{F_{a0} \cdot R}{2 \pi} \times 10^{-3}$$

Where  $T_p$  : Normal operation torque (N·m)  
 $F_{a0}$  : Preload (N)  
 $\beta$  : Lead angle (deg)

Fig. 28 Driving system

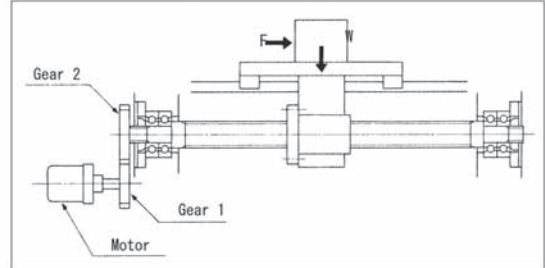

### (2) Driving torque at acceleration

When the ball screw is driven with accelerated velocity against the axial load, the maximum load is required. Torque required at this time can be obtained from the following formula:

$$T_2 = T_1 + J \cdot \dot{\omega}$$

$$J = J_M + J_{G1} + \left(\frac{N_1}{N_2}\right)^2 \left[ J_{G2} + J_s + m \left(\frac{R}{2\pi}\right)^2 \times 10^{-6} \right]$$

Where  $T_2$  : Maximum driving torque at acceleration (N·m)

$\dot{\omega}$  : Angular acceleration of motor (rad/sec<sup>2</sup>)

$J$  : Moment of inertia to motor (kg·m<sup>2</sup>)

$J_M$  : Moment of inertia of motor (kg·m<sup>2</sup>)

$J_{G1}$  : Moment of inertia of gear 1 (kg·m<sup>2</sup>)

$J_{G2}$  : Moment of inertia of gear 2 (kg·m<sup>2</sup>)

$J_s$  : Moment of inertia of screw shaft (kg·m<sup>2</sup>)

$m$  : Mass of transfer material (kg)

(Note) Moment of inertia of cylindrical components

$$J = m \left( \frac{D^2}{8} \right) \times 10^{-6} \text{ (kg·m}^2\text{)}$$

Where  $m$  : Mass of cylinder (kg)

$D$  : Diameter of cylinder (mm)

## 8.2 Driving Torque of motor

### (1) Driving torque at constant speed

Torque  $T_1$  required for driving the ball screw at constant speed against the external load can be obtained from the following formula:

$$T_1 = (T_a + T_p + T_b) \times \frac{N_1}{N_2}$$

Where  $T_a$  : Driving torque at constant speed =  $\frac{F_a \cdot R}{2 \pi \cdot \eta}$  (N·m)

$F_a = F + \mu \cdot W$  (N) • In case of horizontal position

$F$  : Cutting force in screw shaft direction (N)

$\mu$  : Frictional coefficient of sliding surface

$W$  : Weight of table and work (N)

(Weight of table + Weight of work)

$T_b$  : Frictional torque of support bearing (N·m)

$N_1$  : Number of teeth of gear 1

$N_2$  : Number of teeth of gear 2

# 9. LUBRICATION AND DUST-PROOFING

## 9.1 Lubrication

Ball screws feature "No seizure under no lubricant" However a proper amount of lubricant is required from the viewpoint of the life expectancy and machine efficiency. Generally, grease and oil are used as lubricants. For lubrication with grease, lithium soap-based grease is used and for lubrication with oil, oil of ISO grade 32 — 100 is used.

Usually, lubricants with low base oil viscosity are recommended for high-speed, low-temperature and light load applications. Lubricants with high base oil viscosity are recommended for sliding, low-speed, high-temperature and high load applications. Lubricants, Inspection Period and Supply are listed in table 8.

**Table 8. List of recommended lubricants**

Lubricant	Inspection period	Check point	Supply
Grease	Initial 2 — 3 months	Dirt and foreign matter	Supply (proper amount according to inspection results) every year. Wipe off old grease before supplying new grease.
Oil	Every week	Oil quantity and dirt	Supply new oil at the time of every inspection.

## 9.2 Dust-proofing

Similar to a roller bearing, if dust or foreign matter gets into the ball nut of a ball screw, it may cause damage to the thread groove surface or may hasten the wear of such parts, resulting in failure of the circulating mechanism and causing the ball screw to be inoperative. When entry of dust or foreign matter from the outside is anticipated, completely protect the screw shaft with bellows or a screw cover as shown in Fig. 29.

If it is impossible to mount these covers due to the design involved, fit seals (Fig. 30) at both ends of the ball nut for dust-proofing. However, the dust-proofing effect has its limit.

Sankyo Precision ball screws are provided with seals upon request.

**Fig. 30 Seal**

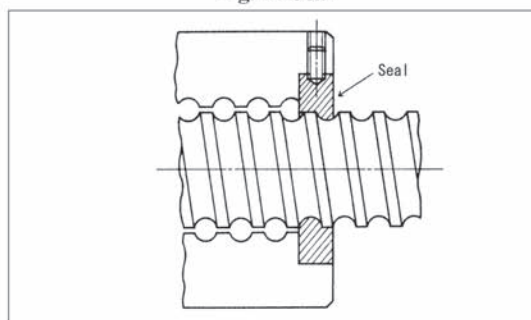

**Fig. 29 Dust-proofing cover**

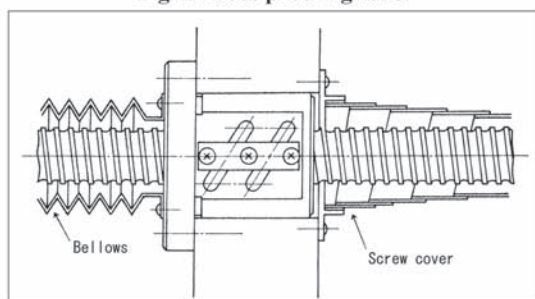



# 10. GEOMETRY OF NUTS

**Type: DC** ..... See Pages 26 and 27.

RETURN GUIDE TYPE SINGLE FLANGE SINGLE NUT  
(Non-preloaded)

Simplest type using a single nut. For use in slight axial clearance.

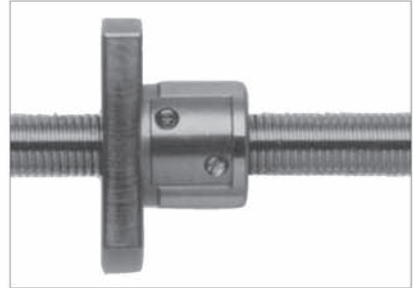

**Type: DP** ..... See Pages 28 and 29.

RETURN GUIDE TYPE SINGLE FLANGE SINGLE NUT  
(Over-size ball preloaded)

Designed to preload with a single nut. Steel balls whose diameter is slightly larger than clearance between screw shaft and thread groove of nut are put in the nut and preloaded. The ratio of load balls to spacer balls used there is 1:1 Suitable for light preload (See Page 17.)

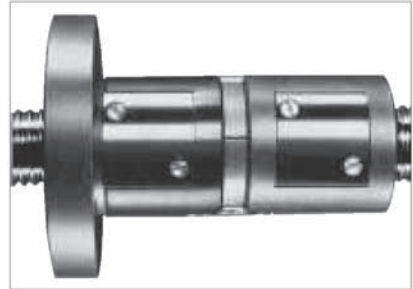

**Type: DD** ..... See Pages 30 and 31.

RETURN GUIDE TYPE SINGLE FLANGE DOUBLE  
NUT (Spacer preloaded)

Designed to preload with two nuts. A spacer with thickness equivalent to amount of preload is put between these two nuts and preloaded as prescribed. Suitable for medium preload. (See Page 17.)

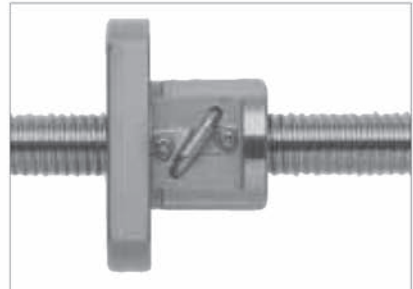

**Type: TCS** ..... See Pages 32 and 33.

TUBULAR TYPE SMALL LEAD, SINGLE FLANGE  
SINGLE NUT (Non-preloaded)

Simplest type using a single nut. For use in slight axial clearance.

**Type: TPS** ..... See Pages 34 and 35.

TUBULAR TYPE SMALL LEAD, SINGLE FLANGE  
SINGLE NUT (Over-size ball preloaded)

Designed to preload with a single nut. Steel balls whose diameter is slightly larger than clearance between screw shaft and thread groove of nut are put in the nut and preloaded. The ratio of load balls to spacer balls used there is 1:1. Suitable for light preload (See Page 17.)



**Type: TDS** ..... See Pages 36 and 37.

TUBULAR TYPE SMALL LEAD, SINGLE FLANGE  
DOUBLE NUT (Spacer preloaded)

Designed to preload with two nuts. A spacer with thickness equivalent to amount of preload is put between these two nuts and preloaded as prescribed. Suitable for medium preload. (See Page 17.)

# 10. GEOMETRY OF NUTS

**Type: TC** ..... See Pages 38 to 41.

TUBULAR TYPE SINGLE FLANGE SINGLE NUT (Non-preloaded)

Simplest type using a single nut. For use in slight axial clearance.

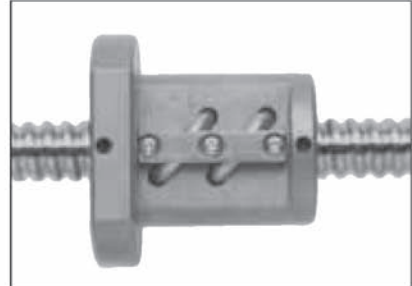

**Type: TP** ..... See Pages 42 to 45.

TUBULAR TYPE SINGLE FLANGE SINGLE NUT (Over-size ball preloaded)

Designed to preload with a single nut. Steel balls whose diameter is slightly larger than clearance between screw shaft and thread groove of nut are put in the nut and preloaded. The ratio of load balls to spacer balls used there is 1:1. Suitable for light load. (See Page 17.)

**Type: TF** ..... See Pages 46 to 49.

TUBULAR TYPE SINGLE FLANGE SINGLE NUT (Offset lead preloaded)

Designed to preload with a single nut. Lead along the center of nut is enlarged by an amount of preload and preloaded. Suitable for medium preload. (See Page 17.)

**Type: TD** ..... See Pages 50 to 53.

TUBULAR TYPE SINGLE FLANGE DOUBLE NUT (Spacer preloaded)

Designed to preload with two nuts. A spacer with thickness equivalent to amount of preload is put between these two nuts and preloaded as prescribed. Suitable for medium and heavy preload. (See Page 17.)



**Type: TCL** ..... See Pages 54 and 55.

TUBULAR TYPE HIGH LEAD SINGLE FLANGE SINGLE NUT (Non-preloaded)

Simplest type using a single nut. For use in slight axial clearance.

**Type: TPL** ..... See Pages 56 and 57.

TUBULAR TYPE HIGH LEAD SINGLE FLANGE SINGLE NUT (Over-size ball preloaded)

Designed to preload with a single nut. Steel balls whose diameter is slightly larger than clearance between screw shaft and thread groove of nut are put in the nut and preloaded. The ratio of load balls to spacer balls used there is 1:1. Suitable for light load (See Page 17.)

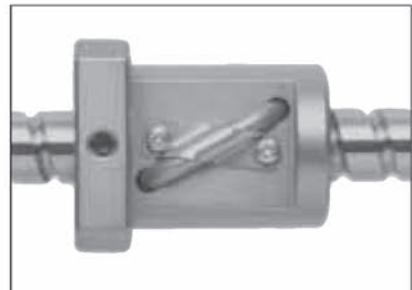

**Type: KC**..... See Pages 58 and 59.

DEFLECTOR TYPE SINGLE FLANGE SINGLE NUT (Non-preloaded)

Simplest type using a single nut. For use in slight axial clearance.

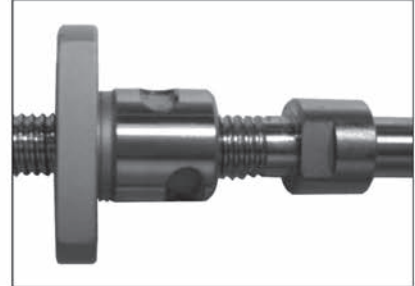

**Type: KP**..... See Pages 58 and 59.

DEFLECTOR TYPE SINGLE FLANGE SINGLE NUT (Over-size ball preloaded)

Designed to preload with a single nut. Steel balls whose diameter is slightly larger than clearance between screw shaft and thread groove of nut are put in the nut and preloaded. The ratio of load balls to spacer balls used there is 1:1. Suitable for light load. (See Page 17.)

**Type: EC**..... See Pages 60 and 61.

END DEFLECTOR TYPE SINGLE FLANGE SINGLE NUT (Non-preloaded)

Simplest type using a single nut. For use in slight axial clearance.

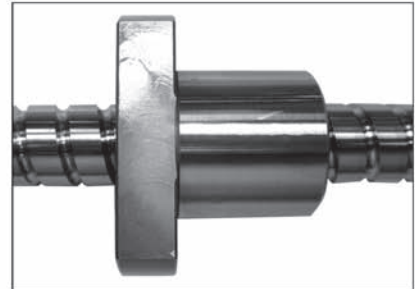

**Type: EP**..... See Pages 60 and 61.

END DEFLECTOR TYPE SINGLE FLANGE SINGLE NUT (Over-size ball preloaded)

Designed to preload with a single nut. Steel balls whose diameter is slightly larger than clearance between screw shaft and thread groove of nut are put in the nut and preloaded. The ratio of load balls to spacer balls used there is 1:1. Suitable for light load. (See Page 17.)

# RETURN GUIDE TYPE SINGLE FLANGE SINGLE NUT

## DC TYPE (Non-preloaded)

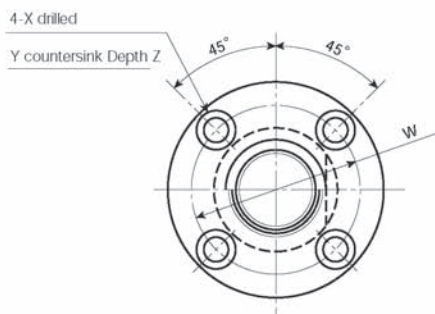

R type (standard)

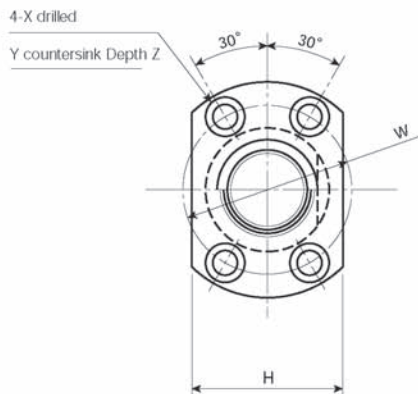

H type

Nut type	Screw O.D <b>d</b>	Lead <b>ℓ</b>	Steel ball dia. <b>Da</b>	Center-circle dia. of steel ball <b>dm</b>	Screw root dia. <b>dr</b>	Number of turns and circuits <b>Turns × Circ.</b>	Basic rated load (N)		Stiffness (N/μm) <b>K</b>
							Dynamic <b>Ca</b>	Static <b>Coa</b>	
DC 0301	3	1	0.600	3.15	2.5	3.7 × 1	34	64	4.2
DC 0401	4	1	0.800	4.15	3.3	3.7 × 1	59	108	5.4
DC 0501	5	1	0.800	5.15	4.3	3.7 × 1	69	137	6.9
DC 0601	6	1	0.800	6.15	5.3	3.7 × 1	74	167	7.8
DC 0601.5		1.5	1.000	6.2	5.1		98	196	7.8
DC 0602		2	(1/16) 1.5875	6.3	4.6		177	304	8.3
DC 0801	8	1	0.800	8.15	7.3	3.7 × 1	83	206	9.8
DC 0801.5		1.5	1.000	8.2	7.1		108	265	9.8
DC 1001	10	1	0.800	10.15	9.3	3.7 × 1	88	265	12
DC 1001.5		1.5	1.000	10.2	9.1		127	343	12
DC 1201	12	1	0.800	12.15	11.3	3.7 × 1	98	314	14
DC 1401	14	1	0.800	14.15	13.3	3.7 × 1	108	363	16

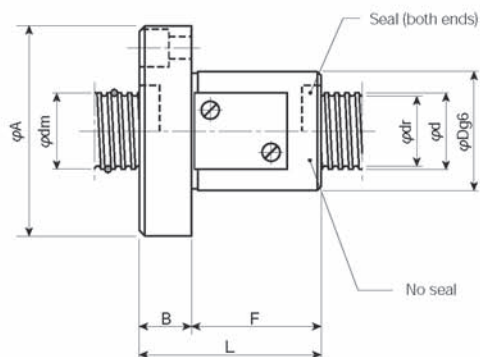

### Remarks

- (1) Flange configuration  
As shown in Fig. on the left side, two flange configurations R type (standard) and H type are available. Select the correct one according to the space for the nut mouting portion.
- (2) Seal  
The standard type is not provided with a seal. However, it is also possible to attach seals to both ends of the nut.
- (3) Stiffness  
Stiffness shown in Table below is a theoretical value obtained from elastic deformation between the thread groove and steel ball when an axial load is equivalent to 30% of basic rated dynamic load ( $C_a$ ) is applied. It is recommended to use 80% of each value given in Table below.

Unit (mm)

Nut dimensions										Nut type
D	A	B	F	L	W	X	Y	Z	H	
9	22	4	15	19	15	3	5.5	2	15	DC 0301
11	24	4	16	20	17	3	5.5	2	16	DC 0401
12	25	4	16	20	18	3	5.5	2	17	DC 0501
13	30	5	16	21	21.5	3.4	6.5	3	20	DC 0601
14	30	5	18	23	22	3.4	6.5	3	20	DC 0601.5
18	34	5	22	27	26	3.4	6.5	3	22	DC 0602
16	32	5	16	21	24	3.4	6.5	3	21	DC 0801
16	32	5	18	23	24	3.4	6.5	3	21	DC 0801.5
19	39	6	16	22	29	4.5	8	4	26	DC 1001
19	39	6	18	24	29	4.5	8	4	26	DC 1001.5
21	41	6	16	22	31	4.5	8	4	26	DC 1201
24	47	8	16	24	35	5.5	9.5	5.5	30	DC 1401

# RETURN GUIDE TYPE SINGLE FLANGE SINGLE NUT

## DP TYPE (Oversize ball preloaded)

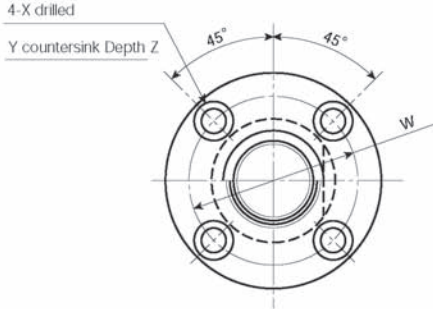

R type (standard)

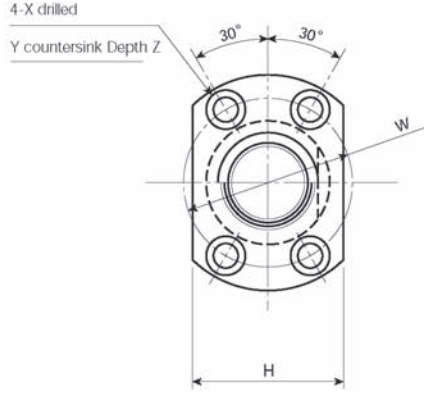

H type

Nut type	Screw O.D <b>d</b>	Lead $\ell$	Steel ball dia. <b>Da</b>	Center-circle dia. of steel ball <b>dm</b>	Screw root dia. <b>dr</b>	Number of turns and circuits <b>Turns×Circ.</b>	Basic rated load (N)		Stiffness (N/μm) <b>K</b>
							Dynamic <b>Ca</b>	Static <b>Coa</b>	
DP 0301	3	1	0.600	3.15	2.5	3.7 × 1	25	34	3.9
DP 0401	4	1	0.800	4.15	3.3	3.7 × 1	34	54	4.6
DP 0501	5	1	0.800	5.15	4.3	3.7 × 1	39	69	5.6
DP 0601	6	1	0.800	6.15	5.3	3.7 × 1	44	79	6.6
DP 0601.5		1.5	1.000	6.2	5.1		59	98	6.9
DP 0602		2	(1/16) 1.5875	6.3	4.6		113	162	7.4
DP 0801	8	1	0.800	8.15	7.3	3.7 × 1	49	108	8.1
DP 0801.5		1.5	1.000	8.2	7.1		69	132	8.5
DP 1001	10	1	0.800	10.15	9.3	3.7 × 1	59	132	9.8
DP 1001.5		1.5	1.000	10.2	9.1		79	167	11
DP 1201	12	1	0.800	12.15	11.3	3.7 × 1	64	157	12
DP 1401	14	1	0.800	14.15	13.3	3.7 × 1	69	181	13

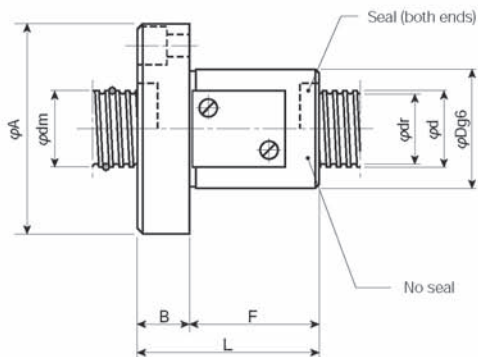

### Remarks

- (1) Flange configuration  
As shown in Fig. on the left side, two flange configurations R type (standard) and H type are available. Select the correct one according to the space for the nut mounting portion.
- (2) Seal  
The standard type is not provided with a seal. However, it is also possible to attach seals to both ends of the nut.
- (3) Basic rated load  
Since the ratio of load balls to spacer balls put in the nut is 1:1, the basic rated load of this type differs from that of the other types.
- (4) Stiffness  
Stiffness shown in Table below is a theoretical value obtained from elastic deformation between the thread groove and steel ball when an axial load is applied, assuming that the preload is 5% of basic rated dynamic load ( $C_a$ ). It is recommended to use 80% of each value given in Table below.

Unit (mm)

Nut dimensions										Nut type
D	A	B	F	L	W	X	Y	Z	H	
9	22	4	15	19	15	3	5.5	2	15	DP 0301
11	24	4	16	20	17	3	5.5	2	16	DP 0401
12	25	4	16	20	18	3	5.5	2	17	DP 0501
13	30	5	16	21	21.5	3.4	6.5	3	20	DP 0601
14	30	5	18	23	22	3.4	6.5	3	20	DP 0601.5
18	34	5	22	27	26	3.4	6.5	3	22	DP 0602
16	32	5	16	21	24	3.4	6.5	3	21	DP 0801
16	32	5	18	23	24	3.4	6.5	3	21	DP 0801.5
19	39	6	16	22	29	4.5	8	4	26	DP 1001
19	39	6	18	24	29	4.5	8	4	26	DP 1001.5
21	41	6	16	22	31	4.5	8	4	26	DP 1201
24	47	8	16	24	35	5.5	9.5	5.5	30	DP 1401

# RETURN GUIDE TYPE SINGLE FLANGE SINGLE NUT

## DD TYPE (Spacer preloaded)

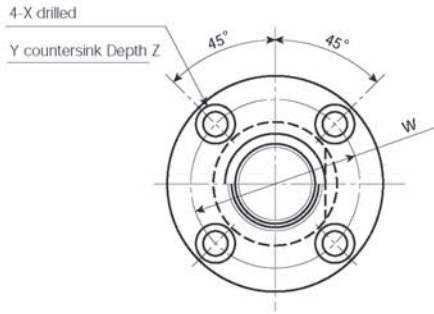

R type (standard)

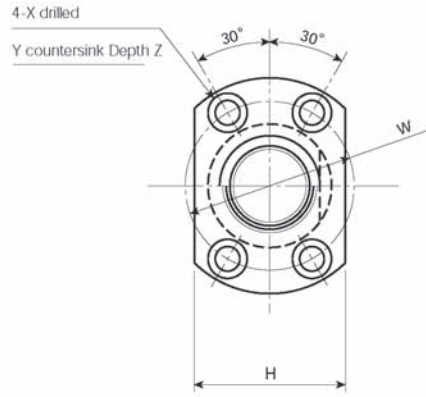

H type

Nut type	Screw O.D <b>d</b>	Lead $\ell$	Steel ball dia. <b>Da</b>	Center-circle dia. of steel ball <b>dm</b>	Screw root dia. <b>dr</b>	Number of turns and circuits <b>Turns × Circ.</b>	Basic rated load (N)		Stiffness (N/μm) <b>K</b>
							Dynamic <b>Ca</b>	Static <b>Coa</b>	
DD 0601	6	1	0.800	6.15	5.3	$3.7 \times 1$	74	167	16
DD 0601.5		1.5	1.000	6.2	5.1		98	196	16
DD 0602		2	(1/16) 1.5875	6.3	4.6		177	304	17
DD 0801	8	1	0.800	8.15	7.3	$3.7 \times 1$	83	206	20
DD 0801.5		1.5	1.000	8.2	7.1		108	265	20
DD 1001	10	1	0.800	10.15	9.3	$3.7 \times 1$	88	265	24
DD 1001.5		1.5	1.000	10.2	9.1		127	343	25
DD 1201	12	1	0.800	12.15	11.3	$3.7 \times 1$	98	314	27
DD 1401	14	1	0.800	14.15	13.3	$3.7 \times 1$	108	363	30



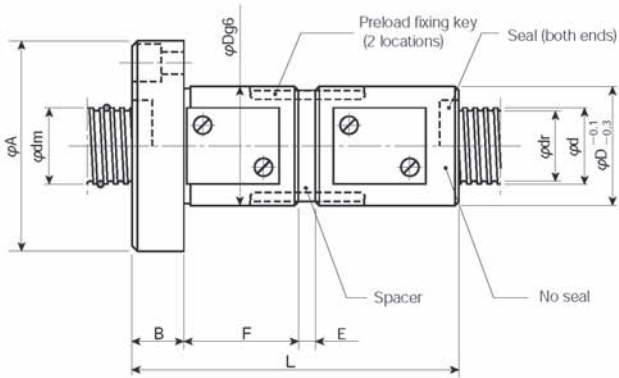

### Remarks

(1) Flange configuration

As shown in Fig. on the left side, two flange configurations R type (standard) and H type are available. Select the correct one according to the space for the nut mounting portion.

(2) Seal

The standard type is not provided with a seal. However, it is also possible to attach seals to both ends of the nut.

(3) Stiffness

Stiffness shown in Table below is a theoretical value obtained from elastic deformation between the thread groove and steel ball when an axial load is applied, assuming that the preload is 10% of basic rated dynamic load (Ca). It is recommended to use 80% of each value given in Table below.

Unit (mm)

Nut dimensions											Nut type
D	A	B	F	E	L	W	X	Y	Z	H	
13	30	5	16	2	43	21.5	3.4	6.5	3	20	DD 0601
14	30	5	18	2	47	22	3.4	6.5	3	20	DD 0601.5
18	34	5	22	4	57	26	3.4	6.5	3	22	DD 0602
16	32	5	16	2	43	24	3.4	6.5	3	21	DD 0801
16	32	5	18	2	47	24	3.4	6.5	3	21	DD 0801.5
19	39	6	16	2	44	29	4.5	8	4	26	DD 1001
19	39	6	18	2	48	29	4.5	8	4	26	DD 1001.5
21	41	6	16	2	44	31	4.5	8	4	26	DD 1201
24	47	8	16	4	48	35	5.5	9.5	5.5	30	DD 1401

# TUBULAR TYPE SMALL LEAD SINGLE FLANGE SINGLE NUT

## TCS TYPE (Non-preloaded)

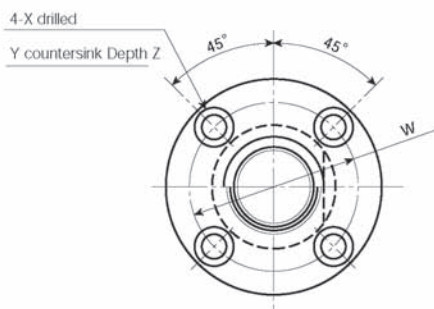

R type (standard)

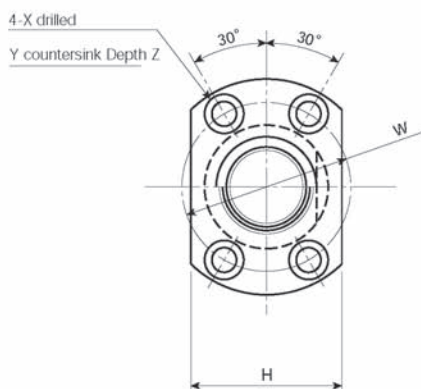

H type

Nut type	Screw O.D <b>d</b>	Lead <b>ℓ</b>	Steel ball dia. <b>Da</b>	Center-circle dia. of steel ball <b>dm</b>	Screw root dia. <b>dr</b>	Number of turns and circuits <b>Turns × Circ.</b>	Basic rated load (N)		Stiffness (N/μm) <b>K</b>
							Dynamic <b>Ca</b>	Static <b>Ca0</b>	
TCS 0802-3.5	8	2	(1/16) 1.5875	8.3	6.6	3.5 × 1	245	400	11
TCS 0802.5-3.5		2.5	2.000	8.3	6.2		320	495	11
TCS 0803-3.5		3	(3/32) 2.381	8.3	5.8		390	575	11
TCS 1002-3.5	10	2	(1/16) 1.5875	10.3	8.6	3.5 × 1	270	505	13
TCS 1002.5-3.5		2.5	2.000	10.3	8.2		365	630	13
TCS 1003-3.5		3	(3/32) 2.381	10.3	7.8		450	735	14
TCS 1202-3.5	12	2	(1/16) 1.5875	12.3	10.6	3.5 × 1	295	610	15
TCS 1202.5-3.5		2.5	2.000	12.3	10.2		400	760	16
TCS 1203-3.5		3	(3/32) 2.381	12.3	9.8		500	895	16
TCS 1402-3.5	14	2	(1/16) 1.5875	14.3	12.6	3.5 × 1	315	715	17
TCS 1402.5-3.5		2.5	2.000	14.3	12.2		430	890	18
TCS 1403-3.5		3	(3/32) 2.381	14.3	11.8		540	1050	18
TCS 1602-3.5	16	2	(1/16) 1.5875	16.3	14.6	3.5 × 1	335	820	19
TCS 1602.5-3.5		2.5	2.000	16.3	14.2		455	1030	20

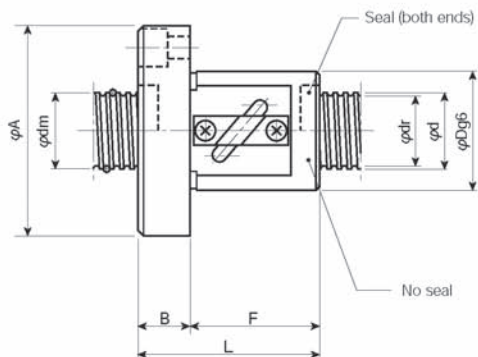

### Remarks

- (1) Flange configuration  
As shown in Fig. on the left side, two flange configurations R type (standard) and H type are available. Select the correct one according to the space for the nut mounting portion.
- (2) Seal  
The standard type is not provided with a seal. However, it is also possible to attach seals to both ends of the nut.
- (3) Stiffness  
Stiffness shown in Table below is a theoretical value obtained from elastic deformation between the thread groove and steel ball when an axial load is applied, assuming that the preload is 30% of basic rated dynamic load (Ca). It is recommended to use 80% of each value given in Table below.

Unit (mm)

Nut dimensions										Nut type
D	A	B	F	L	W	X	Y	Z	H	
20	40	6	22	28	30	4.5	8	4	26	TCS 0802-3.5
20	40	6	25	31	30	4.5	8	4	26	TCS 0802.5-3.5
22	46	8	27	35	34	5.5	9.5	5.5	30	TCS 0803-3.5
23	43	6	22	28	33	4.5	8	4	28	TCS 1002-3.5
24	47	8	25	33	35	5.5	9.5	5.5	30	TCS 1002.5-3.5
26	49	8	27	35	37	5.5	9.5	5.5	31	TCS 1003-3.5
25	48	8	22	30	36	5.5	9.5	5.5	31	TCS 1202-3.5
26	49	8	25	33	37	5.5	9.5	5.5	31	TCS 1202.5-3.5
28	51	8	27	35	39	5.5	9.5	5.5	32	TCS 1203-3.5
26	49	8	22	30	37	5.5	9.5	5.5	31	TCS 1402-3.5
28	51	8	25	33	39	5.5	9.5	5.5	32	TCS 1402.5-3.5
30	54	8	27	35	42	5.5	9.5	5.5	34	TCS 1403-3.5
28	51	8	22	30	39	5.5	9.5	5.5	32	TCS 1602-3.5
32	55	8	25	33	43	5.5	9.5	5.5	34	TCS 1602.5-3.5

# TUBULAR TYPE SMALL LEAD SINGLE FLANGE SINGLE NUT

## TPS TYPE (Oversize ball preloaded)

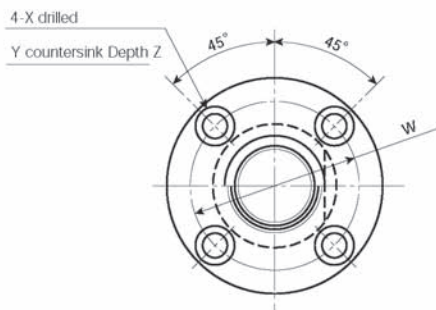

R type (standard)

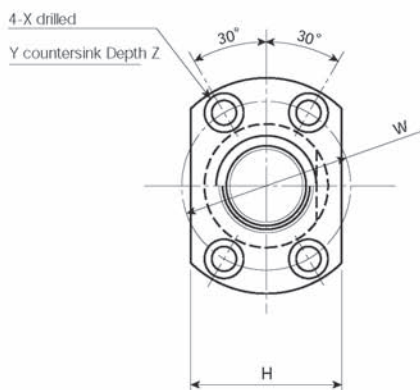

H type

Nut type	Screw O.D <b>d</b>	Lead <i>ℓ</i>	Steel ball dia. <b>Da</b>	Center-circle dia. of steel ball <b>dm</b>	Screw root dia. <b>dr</b>	Number of turns and circuits <b>Turns × Circ.</b>	Basic rated load (N)		Stiffness (N/μm) <b>K</b>
							Dynamic <b>Ca</b>	Static <b>Coa</b>	
TPS 0802-3.5	8	2	(1/16) 1.5875	8.3	6.6	3.5 × 1	155	200	9.4
TPS 0802.5-3.5		2.5	2.000	8.3	6.2		200	245	9.5
TPS 0803-3.5		3	(3/32) 2.381	8.3	5.8		245	290	9.6
TPS 1002-3.5	10	2	(1/16) 1.5875	10.3	8.6	3.5 × 1	170	255	11
TPS 1002.5-3.5		2.5	2.000	10.3	8.2		230	315	12
TPS 1003-3.5		3	(3/32) 2.381	10.3	7.8		285	365	12
TPS 1202-3.5	12	2	(1/16) 1.5875	12.3	10.6	3.5 × 1	185	305	13
TPS 1202.5-3.5		2.5	2.000	12.3	10.2		250	380	13
TPS 1203-3.5		3	(3/32) 2.381	12.3	9.8		315	445	14
TPS 1402-3.5	14	2	(1/16) 1.5875	14.3	12.6	3.5 × 1	200	360	15
TPS 1402.5-3.5		2.5	2.000	14.3	12.2		270	445	15
TPS 1403-3.5		3	(3/32) 2.381	14.3	11.8		340	525	15
TPS 1602-3.5	16	2	(1/16) 1.5875	16.3	14.6	3.5 × 1	210	410	16
TPS 1602.5-3.5		2.5	2.000	16.3	14.2		290	510	17

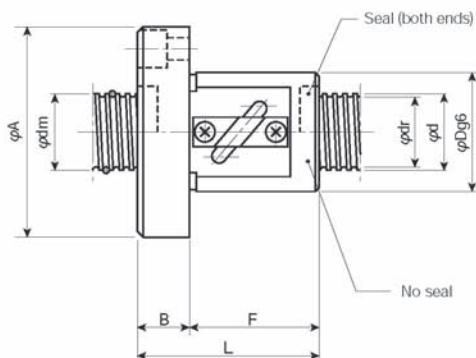

### Remarks

- (1) Flange configuration  
As shown in Fig. on the left side, two flange configurations R type (standard) and H type are available. Select the correct one according to the space for the nut mounting portion.
- (2) Seal  
The standard type is not provided with a seal. However, it is also possible to attach seals to both ends of the nut.
- (3) Basic rated load  
Since the ratio of load balls to spacer balls put in the nut is 1:1, the basic rated load of this type differs from that of the other types.
- (4) Stiffness  
Stiffness shown in Table below is a theoretical value obtained from elastic deformation between the thread groove and steel ball when an axial load is applied, assuming that the preload is 5% of basic rated dynamic load (Ca). It is recommended to use 80% of each value given in Table below.

Unit (mm)

Nut dimensions										Nut type
D	A	B	F	L	W	X	Y	Z	H	
20	40	6	22	28	30	4.5	8	4	26	TPS 0802-3.5
20	40	6	25	31	30	4.5	8	4	26	TPS 0802.5-3.5
22	46	8	27	35	34	5.5	9.5	5.5	30	TPS 0803-3.5
23	43	6	22	28	33	4.5	8	4	28	TPS 1002-3.5
24	47	8	25	33	35	5.5	9.5	5.5	30	TPS 1002.5-3.5
26	49	8	27	35	37	5.5	9.5	5.5	31	TPS 1003-3.5
25	48	8	22	30	36	5.5	9.5	5.5	31	TPS 1202-3.5
26	49	8	25	33	37	5.5	9.5	5.5	31	TPS 1202.5-3.5
28	51	8	27	35	39	5.5	9.5	5.5	32	TPS 1203-3.5
26	49	8	22	30	37	5.5	9.5	5.5	31	TPS 1402-3.5
28	51	8	25	33	39	5.5	9.5	5.5	32	TPS 1402.5-3.5
30	54	8	27	35	42	5.5	9.5	5.5	34	TPS 1403-3.5
28	51	8	22	30	39	5.5	9.5	5.5	32	TPS 1602-3.5
32	55	8	25	33	43	5.5	9.5	5.5	34	TPS 1602.5-3.5

# TUBULAR TYPE SMALL LEAD SINGLE FLANGE SINGLE NUT

## TDS TYPE (Spacer preloaded)

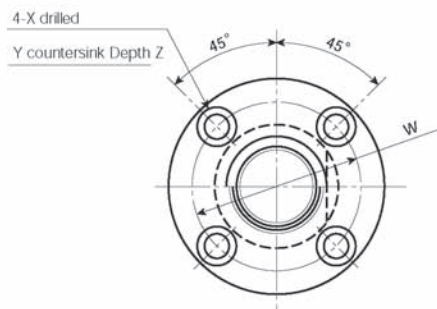

R type (standard)

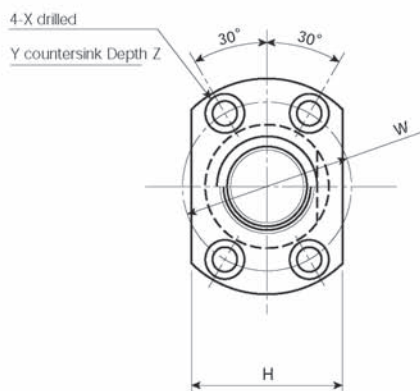

H type

Nut type	Screw O.D <b>d</b>	Lead <b>ℓ</b>	Steel ball dia. <b>Da</b>	Center-circle dia. of steel ball <b>dm</b>	Screw root dia. <b>dr</b>	Number of turns and circuits <b>Turns × Circ.</b>	Basic rated load (N)		Stiffness (N/μm) <b>K</b>
							Dynamic <b>Ca</b>	Static <b>Ca0</b>	
TDS 0802-3.5	8	2	(1/16) 1.5875	8.3	6.6	3.5 × 1	245	400	22
TDS 0802.5-3.5		2.5	2.000	8.3	6.2		320	495	22
TDS 0803-3.5		3	(3/32) 2.381	8.3	5.8		390	575	22
TDS 1002-3.5	10	2	(1/16) 1.5875	10.3	8.6	3.5 × 1	270	505	26
TDS 1002.5-3.5		2.5	2.000	10.3	8.2		365	630	27
TDS 1003-3.5		3	(3/32) 2.381	10.3	7.8		450	735	27
TDS 1202-3.5	12	2	(1/16) 1.5875	12.3	10.6	3.5 × 1	295	610	30
TDS 1202.5-3.5		2.5	2.000	12.3	10.2		400	760	31
TDS 1203-3.5		3	(3/32) 2.381	12.3	9.8		500	895	32
TDS 1402-3.5	14	2	(1/16) 1.5875	14.3	12.6	3.5 × 1	315	715	34
TDS 1402.5-3.5		2.5	2.000	14.3	12.2		430	890	35
TDS 1403-3.5		3	(3/32) 2.381	14.3	11.8		540	1050	36
TDS 1602-3.5	16	2	(1/16) 1.5875	16.3	14.6	3.5 × 1	335	820	38
TDS 1602.5-3.5		2.5	2.000	16.3	14.2		455	1030	39

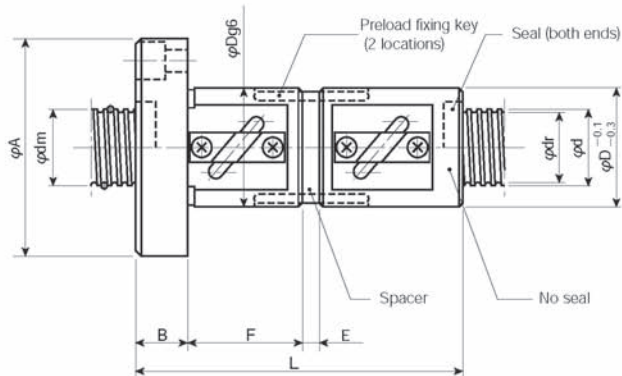

### Remarks

(1) Flange configuration

As shown in Fig. on the left side, two flange configurations R type (standard) and H type are available. Select the correct one according to the space for the nut mounting portion.

(2) Seal

The standard type is not provided with a seal. However, it is also possible to attach seals to both ends of the nut.

(3) Stiffness

Stiffness shown in Table below is a theoretical value obtained from elastic deformation between the thread groove and steel ball when an axial load is applied, assuming that the preload is 10% of basic rated dynamic load (Ca). It is recommended to use 80% of each value given in Table below.

Unit (mm)

Nut dimensions											Nut type
D	A	B	F	E	L	W	X	Y	Z	H	
20	40	6	22	4	58	30	4.5	8	4	26	TDS 0802-3.5
20	40	6	25	5	66	30	4.5	8	4	26	TDS 0802.5-3.5
22	46	8	27	4	71	34	5.5	9.5	5.5	30	TDS 0803-3.5
23	43	6	22	4	58	33	4.5	8	4	28	TDS 1002-3.5
24	47	8	25	5	68	35	5.5	9.5	5.5	30	TDS 1002.5-3.5
26	49	8	27	4	71	37	5.5	9.5	5.5	31	TDS 1003-3.5
25	48	8	22	4	60	36	5.5	9.5	5.5	31	TDS 1202-3.5
26	49	8	25	5	68	37	5.5	9.5	5.5	31	TDS 1202.5-3.5
28	51	8	27	4	71	39	5.5	9.5	5.5	32	TDS 1203-3.5
26	49	8	22	4	60	37	5.5	9.5	5.5	31	TDS 1402-3.5
28	51	8	25	5	68	39	5.5	9.5	5.5	32	TDS 1402.5-3.5
30	54	8	27	4	71	42	5.5	9.5	5.5	34	TDS 1403-3.5
28	51	8	22	4	60	39	5.5	9.5	5.5	32	TDS 1602-3.5
32	55	8	25	5	68	43	5.5	9.5	5.5	34	TDS 1602.5-3.5

# TUBULAR TYPE SINGLE FLANGE SINGLE NUT

## TC TYPE (Non-preloaded)

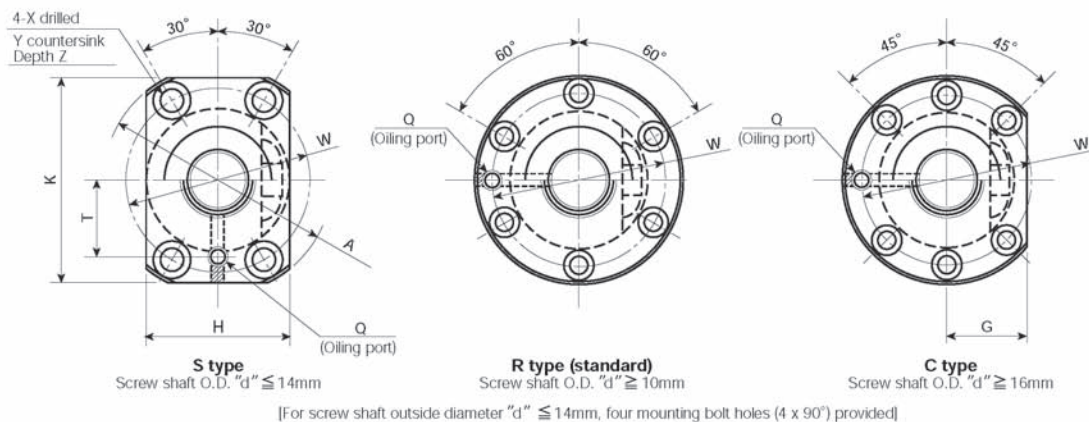

Nut type	Screw O.D. d	Lead ℓ	Steel ball dia. Da	Center-circle dia. of steel ball dm	Screw root dia. dr	Number of turns and circuits Turns×Circ.	Basic rated load (N)		Stiffness (N/μm) K	
							Dynamic Ca	Static Ca		
TC 1004-2.5	10	4	2.000	10.3	8.2	2.5 × 1	275	445	9.8	
TC 1204-2.5	12	4	(3/32) 2.381	12.3	9.8	2.5 × 1	375	635	12	
TC 1205-2.5		5	(3/32) 2.381	12.3	9.8	2.5 × 1	375	635	12	
TC 1404-2.5	14	4	(3/32) 2.381	14.3	11.8	2.5 × 1	405	750	13	
TC 1405-2.5		5	(1/8) 3.175	14.5	11.2	2.5 × 1	685	1190	14	
TC 1604-2.5	16	4	(3/32) 2.381	16.3	13.8	2.5 × 1	435	860	15	
TC 1605-3		5	(1/8) 3.175	16.5	13.2	1.5 × 2	860	1650	19	
TC 1605-2.5			2.5 × 1	735	1370	16				
TC 1605-5			2.5 × 2	1340	2740	31				
TC 1606-3		6	(1/8) 3.175	16.5	13.2	1.5 × 2	860	1650	19	
TC 1606-2.5			2.5 × 1	735	1370	16				
TC 2004-2.5	20	4	(3/32) 2.381	20.3	17.8	2.5 × 1	480	1090	17	
TC 2004-5			2.5 × 2	870	2170	34				
TC 2005-3		5	(1/8) 3.175	20.5	17.2	1.5 × 2	965	2080	23	
TC 2005-2.5			2.5 × 1	820	1730	19				
TC 2005-5			2.5 × 2	1490	3470	37				
TC 2006-3		6	(5/32) 3.969	20.5	16.3	1.5 × 2	1280	2560	23	
TC 2006-2.5			2.5 × 1	1100	2130	20				
TC 2006-5			2.5 × 2	1990	4260	38				
TC 2504-2.5			25	4	(3/32) 2.381	25.3	22.8	2.5 × 1	525	1370
TC 2504-5		2.5 × 2			955	2740	40			
TC 2505-3	5	(1/8) 3.175		25.5	22.2	1.5 × 2	1070	2620	27	
TC 2505-2.5		2.5 × 1		910	2180	23				
TC 2505-5		2.5 × 2		1650	4370	44				
TC 2506-3	6	(5/32) 3.969		25.5	21.3	1.5 × 2	1440	3230	28	
TC 2506-2.5		2.5 × 1		1230	2690	23				
TC 2506-5		2.5 × 2		2230	5390	45				



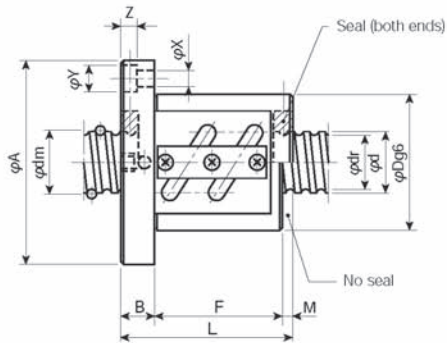

### Remarks

#### (1) Flange configuration

As shown in Fig. on the left side, R type (standard) and S type for shaft outside diameters of less than 14mm and R type (standard) and C type for shaft outside diameters of more than 16mm are available. Select the correct one according to the space for the nut mounting portion. The R type with shaft outside diameters of less than 14mm is provided with four mounting bolt holes ( $4 \times 90^\circ$ ).

#### (2) Seal

For the type with a seal, the nut length is longer than of the type without a seal by M. For the type with shaft outside diameters less than 16mm, the nut has the same length.

#### (3) Stiffness

Stiffness shown in Table below is a theoretical value obtained from elastic deformation between the thread groove and steel ball when an axial load equivalent to 30% of basic rated dynamic load ( $C_a$ ) is applied. It is recommended to use 80% of each value given in Table below.

Nut dimensions														Nut type		Unit (mm)										
D	A	G	B	F	L	M	W	X	Y	Z	Q	T	K	H												
26	46	—	10	27	37	0	36	4.5	8	4.5	M6	14	42	28	TC	1004-2.5										
30	50	—	10	27	37	0	40	4.5	8	4.5	M6	15	45	32	TC	1204-2.5										
30	50	—	10	30	40	0	40	4.5	8	4.5	M6	15	45	32	TC	1205-2.5										
32	55	—	11	27	38	0	43	5.5	9.5	5.5	M6	16	50	34	TC	1404-2.5										
34	57	—	11	30	41	0	45	5.5	9.5	5.5	M6	17	50	34	TC	1405-2.5										
34	57	22	11	27	38	0	45	5.5	9.5	5.5	M6	—	—	—	TC	1604-2.5										
40	63	24	11	41	52	0	51	5.5	9.5	5.5	M6	—	—	—	TC	1605-3										
				31	42										TC	1605-2.5										
				46	57										TC	1605-5										
40	63	24	11	45	56	0	51	5.5	9.5	5.5	M6	—	—	—	TC	1606-3										
				33	44										TC	1606-2.5										
				23	37										TC	2004-2.5										
40	63	24	11	35	49	3	51	5.5	9.5	5.5	M6	—	—	—	TC	2004-5										
				38	52	TC	2005-3																			
				27	41	3	55	5.5	9.5	5.5	M6	—	—	—	TC	2005-2.5										
44	67	26	11	42	56	3	59	5.5	9.5	5.5	M6	—	—	—	TC	2005-5										
				42	56										TC	2006-3										
				30	44										3	59	5.5	9.5	5.5	M6	—	—	—	TC	2006-2.5	
48	71	27	11	48	62	3	57	5.5	9.5	5.5	M6	—	—	—	TC	2006-5										
				22	36										3	57	5.5	9.5	5.5	M6	—	—	—	TC	2504-2.5	
				34	48										TC	2504-5										
46	69	26	11	38	52	3	61	5.5	9.5	5.5	M6	—	—	—	TC	2505-3										
				26	40										3	61	5.5	9.5	5.5	M6	—	—	—	TC	2505-2.5	
				41	55										TC	2505-5										
50	73	28	11	42	56	3	64	5.5	9.5	5.5	M6	—	—	—	TC	2506-3										
				30	44										3	64	5.5	9.5	5.5	M6	—	—	—	TC	2506-2.5	
				48	62										TC	2506-5										

# TUBULAR TYPE SINGLE FLANGE SINGLE NUT

## TC TYPE (Non-preloaded)

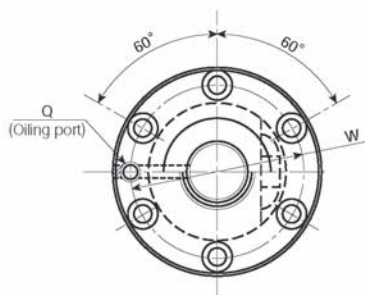

R type (standard)

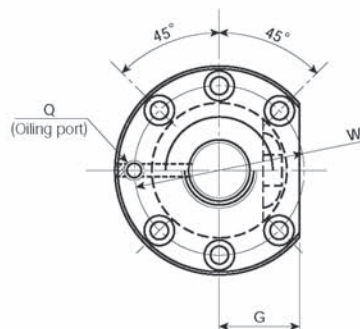

C type

Nut type	Screw O.D <i>d</i>	Lead <i>ℓ</i>	Steel ball dia. <i>Da</i>	Center-circle dia. of steel ball <i>dm</i>	Screw root dia. <i>dr</i>	Number of turns and circuits  Turns×Circ.	Basic rated load (N)		Stiffness (N/μm)  <i>K</i>
							Dynamic <i>Ca</i>	Static <i>C<sub>0a</sub></i>	
TC 2805-2.5	28	5	(1/8)	28.5	25.2	2.5 × 1	955	2450	25
TC 2805-5			3.175			2.5 × 2	1740	4910	48
TC 2806-2.5	28	6	(5/32)	28.5	24.3	2.5 × 1	1290	3030	26
TC 2806-5			3.969			2.5 × 2	2350	6060	50
TC 3204-2.5	32	4	(3/32)	32.3	29.8	2.5 × 1	580	1760	25
TC 3204-5			2.381			2.5 × 2	1050	3520	49
TC 3205-3	32	5	(1/8)	32.5	29.2	1.5 × 2	1180	3380	33
TC 3205-2.5			3.175			2.5 × 1	1010	2810	28
TC 3205-5	32	6	(5/32)	32.5	28.3	2.5 × 1	1830	5630	54
TC 3206-3			3.969			2.5 × 2	1610	4180	34
TC 3206-2.5	32	6	(5/32)	32.5	28.3	2.5 × 1	1370	3480	29
TC 3206-5			3.969			2.5 × 2	2490	6970	55
TC 3605-2.5	36	5	(1/8)	36.5	33.2	2.5 × 1	1060	3170	31
TC 3605-5			3.175			2.5 × 2	1920	6350	59
TC 3606-2.5	36	6	(5/32)	36.5	32.3	2.5 × 1	1440	3930	31
TC 3606-5			3.969			2.5 × 2	2620	7870	61
TC 4005-3	40	5	(1/8)	40.5	37.2	1.5 × 2	1300	4240	40
TC 4005-2.5			3.175			2.5 × 1	1110	3530	33
TC 4005-5	40	6	(5/32)	40.5	36.3	2.5 × 2	2010	7070	64
TC 4005-7.5			3.969			2.5 × 3	2870	10600	95
TC 4006-3	40	6	(5/32)	40.5	36.3	1.5 × 2	1770	5260	41
TC 4006-2.5			3.969			2.5 × 1	1510	4380	34
TC 4006-5	40	6	(5/32)	40.5	36.3	2.5 × 2	2740	8770	66
TC 4006-7.5			3.969			2.5 × 3	3910	13100	98

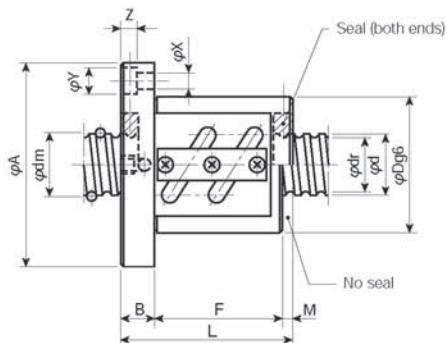

### Remarks

- (1) Flange configuration  
As shown in Fig. on the left side, two flange configurations R type (standard) and H type are available. Select the correct one according to the space for the nut mounting portion.
- (2) Seal  
For the type with a seal, the nut length is longer than of the type without a seal by M.
- (3) Stiffness  
Stiffness shown in Table below is a theoretical value obtained from elastic deformation between the thread groove and steel ball when an axial load is applied, assuming that the preload is 30% of basic rated dynamic load (Ca). It is recommended to use 80% of each value given in Table below.

Unit (mm)

Nut dimensions												Nut type
D	A	G	B	F	L	M	W	X	Y	Z	Q	
55	85	31	12	26	41	3	69	6.6	11	6.5	M6	TC 2805-2.5
				41	56							TC 2805-5
55	85	31	12	30	45	3	69	6.6	11	6.5	M6	TC 2806-2.5
				48	63							TC 2806-5
54	81	31	12	22	37	3	67	6.6	11	6.5	M6	TC 3204-2.5
				34	49							TC 3204-5
58	85	32	12	38	53	3	71	6.6	11	6.5	M6	TC 3205-3
				41	56							TC 3205-2.5
62	89	34	12	42	57	3	75	6.6	11	6.5	M6	TC 3205-5
				48	63							TC 3206-3
65	100	38	15	30	45	3	75	6.6	11	6.5	M6	TC 3206-2.5
				48	63							TC 3206-5
65	100	38	15	26	44	3	82	9	14	8.5	M6	TC 3605-2.5
				41	59							TC 3605-5
65	100	38	15	30	48	3	82	9	14	8.5	M6	TC 3606-2.5
				48	66							TC 3606-5
67	101	39	15	38	56	3	83	9	14	8.5	PT1/8	TC 4005-3
				41	59							TC 4005-2.5
70	104	40	15	56	74	3	86	9	14	8.5	PT1/8	TC 4005-5
				42	60							TC 4005-7.5
70	104	40	15	30	48	3	86	9	14	8.5	PT1/8	TC 4006-3
				48	66							TC 4006-2.5
70	104	40	15	66	84	3	86	9	14	8.5	PT1/8	TC 4006-5
				66	84							TC 4006-7.5

# TUBULAR TYPE SINGLE FLANGE SINGLE NUT

## TP TYPE (Oversize ball preloaded)

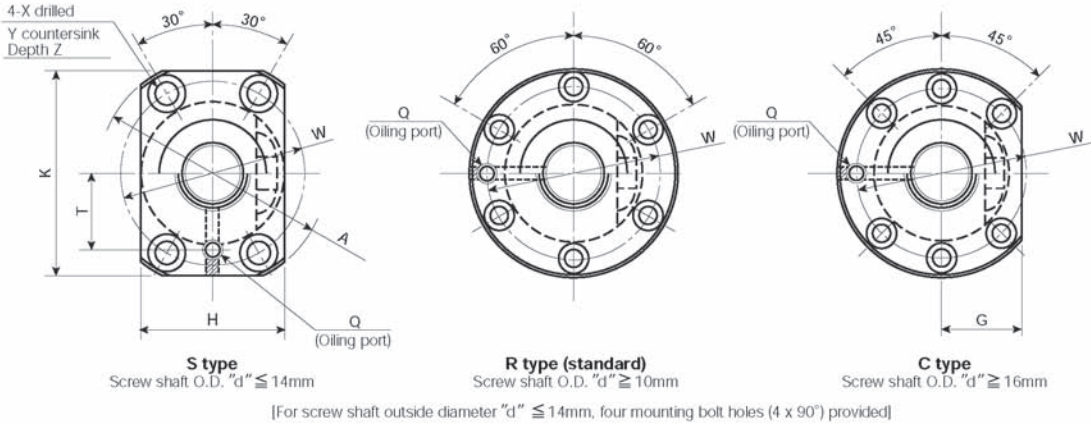

Nut type	Screw O.D. d	Lead ℓ	Steel ball dia. Da	Center-circle dia. of steel ball dm	Screw root dia. dr	Number of turns and circuits Turns × Circ.	Basic rated load (N)		Stiffness (N/μm) K	
							Dynamic Ca	Static Coa		
TP 1004-2.5	10	4	2.000	10.3	8.2	2.5 × 1	170	225	8.3	
TP 1204-2.5	12	4	(3/32) 2.381	12.3	9.8	2.5 × 1	235	320	9.8	
TP 1205-2.5		5	(3/32) 2.381	12.3	9.8	2.5 × 1	235	320	9.8	
TP 1404-2.5	14	4	(3/32) 2.381	14.3	11.8	2.5 × 1	255	375	11	
TP 1405-2.5		5	(1/8) 3.175	14.5	11.2	2.5 × 1	430	595	12	
TP 1604-2.5	16	4	(3/32) 2.381	16.3	13.8	2.5 × 1	270	430	12	
TP 1605-3		5	(1/8) 3.175	16.5	13.2	1.5 × 2	545	820	16	
TP 1605-2.5			2.5 × 1	465	685	14				
TP 1605-5			2.5 × 2	840	1370	26				
TP 1606-3		6	(1/8) 3.175	16.5	13.2	1.5 × 2	545	820	16	
TP 1606-2.5			2.5 × 1	465	685	14				
TP 2004-2.5	20	4	(3/32) 2.381	20.3	17.8	2.5 × 1	300	545	15	
TP 2004-5			2.5 × 2	545	1090	29				
TP 2005-3		5	(1/8) 3.175	20.5	17.2	1.5 × 2	605	1040	19	
TP 2005-2.5			2.5 × 1	520	865	16				
TP 2005-5			2.5 × 2	940	1730	32				
TP 2006-3		6	(5/32) 3.969	20.5	16.3	1.5 × 2	810	1280	20	
TP 2006-2.5			2.5 × 1	690	1060	17				
TP 2006-5			2.5 × 2	1250	2130	32				
TP 2504-2.5		25	4	(3/32) 2.381	25.3	22.8	2.5 × 1	330	680	18
TP 2504-5				2.5 × 2	600	1370	35			
TP 2505-3	5		(1/8) 3.175	25.5	22.2	1.5 × 2	670	1310	23	
TP 2505-2.5			2.5 × 1	575	1090	20				
TP 2505-5			2.5 × 2	1040	2180	38				
TP 2506-3	6		(5/32) 3.969	25.5	21.3	1.5 × 2	905	1620	24	
TP 2506-2.5			2.5 × 1	770	1350	20				
TP 2506-5			2.5 × 2	1400	2690	39				

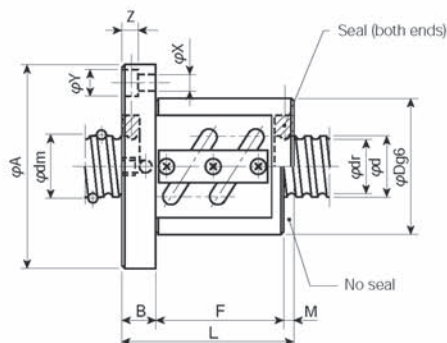

## Remarks

### (1) Flange configuration

As shown in Fig. on the left side, R type (standard) and S type for shaft outside diameters of less than 14mm and R type (standard) and C type for shaft outside diameters of more than 16mm are available. Select the correct one according to the space for the nut mounting portion. The R type with shaft outside diameters of less than 14mm is provided with four mounting bolt holes ( $4 \times 90^\circ$ ).

### (2) Seal

For the type with a seal, the nut length is longer than of the type without a seal by M. For the type with shaft outside diameters less than 16mm, the nut has the same length.

### (3) Basic rated load

Since the ratio of load balls to spacer balls put in the nut is 1:1, the basic rated load of this type differs from that of the other types.

### (4) Stiffness

Stiffness shown in Table below is a theoretical value obtained from elastic deformation between the thread groove and steel ball when an axial load equivalent to 30% of basic rated dynamic load ( $C_a$ ) is applied. It is recommended to use 80% of each value given in Table below.

Unit (mm)

Nut dimensions														Nut type	
D	A	G	B	F	L	M	W	X	Y	Z	Q	T	K	H	
26	46	—	10	27	37	0	36	4.5	8	4.5	M6	14	42	28	TP 1004-2.5
30	50	—	10	27	37	0	40	4.5	8	4.5	M6	15	45	32	TP 1204-2.5
30	50	—	10	30	40	0	40	4.5	8	4.5	M6	15	45	32	TP 1205-2.5
32	55	—	11	27	38	0	43	5.5	9.5	5.5	M6	16	50	34	TP 1404-2.5
34	57	—	11	30	41	0	45	5.5	9.5	5.5	M6	17	50	34	TP 1405-2.5
34	57	22	11	27	38	0	45	5.5	9.5	5.5	M6	—	—	—	TP 1604-2.5
40	63	24	11	41	52	0	51	5.5	9.5	5.5	M6	—	—	—	TP 1605-3
				31	42										TP 1605-2.5
				46	57										TP 1605-5
40	63	24	11	45	56	0	51	5.5	9.5	5.5	M6	—	—	—	TP 1606-3
				33	44										TP 1606-2.5
40	63	24	11	23	37	3	51	5.5	9.5	5.5	M6	—	—	—	TP 2004-2.5
				35	49										TP 2004-5
44	67	26	11	38	52	3	55	5.5	9.5	5.5	M6	—	—	—	TP 2005-3
				27	41										TP 2005-2.5
				42	56										TP 2005-5
48	71	27	11	42	56	3	59	5.5	9.5	5.5	M6	—	—	—	TP 2006-3
				30	44										TP 2006-2.5
				48	62										TP 2006-5
46	69	26	11	22	36	3	57	5.5	9.5	5.5	M6	—	—	—	TP 2504-2.5
				34	48										TP 2504-5
50	73	28	11	38	52	3	61	5.5	9.5	5.5	M6	—	—	—	TP 2505-3
				26	40										TP 2505-2.5
				41	55										TP 2505-5
53	76	29	11	42	56	3	64	5.5	9.5	5.5	M6	—	—	—	TP 2506-3
				30	44										TP 2506-2.5
				48	62										TP 2506-5

# TUBULAR TYPE SINGLE FLANGE SINGLE NUT

## TP TYPE (Oversize ball preloaded)

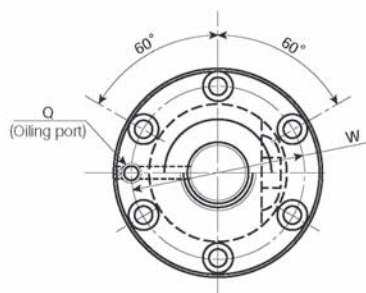

R type (standard)

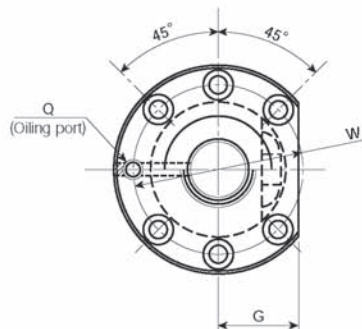

C type

Nut type	Screw O.D <b>d</b>	Lead <b>ℓ</b>	Steel ball dia. <b>Da</b>	Center-circle dia. of steel ball <b>dm</b>	Screw root dia. <b>dr</b>	Number of turns and circuits <b>Turns×Circ.</b>	Basic rated load (N)		Stiffness (N/μm) <b>K</b>
							Dynamic <b>Ca</b>	Static <b>C<sub>0a</sub></b>	
TP 2805-2.5	28	5	(1/8)	28.5	25.2	2.5 × 1	600	1230	21
TP 2805-5			3.175			2.5 × 2	1090	2450	41
TP 2806-2.5	28	6	(5/32)	28.5	24.3	2.5 × 1	815	1520	22
TP 2806-5			3.969			2.5 × 2	1480	3030	43
TP 3204-2.5	32	4	(3/32)	32.3	29.8	2.5 × 1	365	880	22
TP 3204-5			2.381			2.5 × 2	665	1760	42
TP 3205-3	32	5	(1/8)	32.5	29.2	1.5 × 2	745	1690	28
TP 3205-2.5			3.175			2.5 × 1	635	1410	24
TP 3205-5			3.175			2.5 × 2	1160	2810	46
TP 3206-3	32	6	(5/32)	32.5	28.3	1.5 × 2	1010	2090	29
TP 3206-2.5			3.969			2.5 × 1	865	1740	25
TP 3206-5			3.969			2.5 × 2	1570	3480	47
TP 3605-2.5	36	5	(1/8)	36.5	33.2	2.5 × 1	665	1590	26
TP 3605-5			3.175			2.5 × 2	1210	3170	51
TP 3606-2.5	36	6	(5/32)	36.5	32.3	2.5 × 1	910	1970	27
TP 3606-5			3.969			2.5 × 2	1650	3930	52
TP 4005-3	40	5	(1/8)	40.5	37.2	1.5 × 2	815	2120	34
TP 4005-2.5			3.175			2.5 × 1	695	1770	28
TP 4005-5			3.175			2.5 × 2	1260	3530	55
TP 4005-7.5						2.5 × 3	1810	5300	81
TP 4006-3	40	6	(5/32)	40.5	36.3	1.5 × 2	1110	2630	35
TP 4006-2.5			3.969			2.5 × 1	950	2190	29
TP 4006-5			3.969			2.5 × 2	1720	4380	57
TP 4006-7.5						2.5 × 3	2460	6570	84

**Remarks**

(1) Flange configuration

As shown in Fig. on the left side, two flange configurations R type (standard) and H type are available. Select

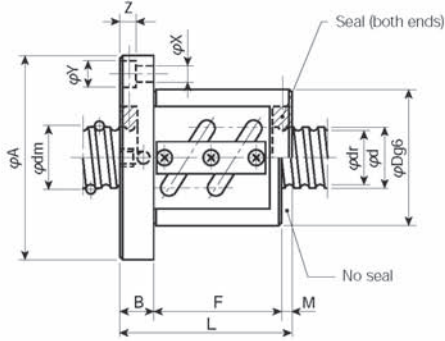

the correct one according to the space for the nut mounting portion.

(2) Seal

For the type with a seal, the nut length is longer than of the type without a seal by M.

(3) Basic rated load

Since the ratio of load balls to spacer balls put in the nut is 1:1, the basic rated load of this type differs from that of the other types.

(4) Stiffness

Stiffness shown in Table below is a theoretical value obtained from elastic deformation between the thread groove and steel ball when an axial load is applied, assuming that the preload is 5% of basic rated dynamic load (Ca). It is recommended to use 80% of each value given in Table below.

Unit (mm)

Nut dimensions												Nut type
D	A	G	B	F	L	M	W	X	Y	Z	Q	
55	85	31	12	26	41	3	69	6.6	11	6.5	M6	TP 2805-2.5
				41	56							TP 2805-5
55	85	31	12	30	45	3	69	6.6	11	6.5	M6	TP 2806-2.5
				48	63							TP 2806-5
54	81	31	12	22	37	3	67	6.6	11	6.5	M6	TP 3204-2.5
				34	49							TP 3204-5
58	85	32	12	38	53	3	71	6.6	11	6.5	M6	TP 3205-3
				26	41							TP 3205-2.5
62	89	34	12	41	56	3	75	6.6	11	6.5	M6	TP 3205-5
				42	57							TP 3206-3
65	100	38	15	30	45	3	82	9	14	8.5	M6	TP 3206-2.5
				48	63							TP 3206-5
65	100	38	15	26	44	3	82	9	14	8.5	M6	TP 3605-2.5
				41	59							TP 3605-5
65	100	38	15	30	48	3	82	9	14	8.5	M6	TP 3606-2.5
				48	66							TP 3606-5
67	101	39	15	38	56	3	83	9	14	8.5	PT1/8	TP 4005-3
				26	44							TP 4005-2.5
70	104	40	15	41	59	3	86	9	14	8.5	PT1/8	TP 4005-5
				56	74							TP 4005-7.5
70	104	40	15	42	60	3	86	9	14	8.5	PT1/8	TP 4006-3
				30	48							TP 4006-2.5
70	104	40	15	48	66	3	86	9	14	8.5	PT1/8	TP 4006-5
				66	84							TP 4006-7.5

# TUBULAR TYPE SINGLE FLANGE SINGLE NUT

## TF TYPE (Offset lead preloaded)

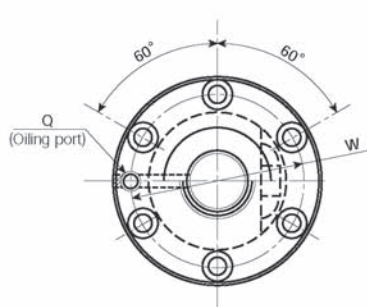

R type (standard)

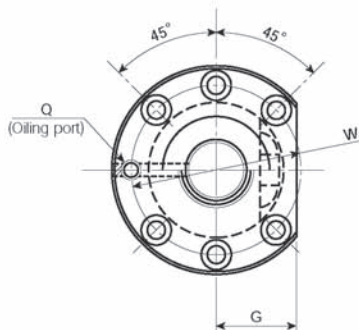

C type

Nut type	Screw O.D	Lead	Steel ball dia.	Center-circle dia. of steel ball	Screw root dia.	Number of turns and circuits	Basic rated load (N)		Stiffness (N/μm)
	d						Ca	C <sub>0a</sub>	
TF 1605-5	16	5	(1/8) 3.175	16.5	13.2	2.5 × 1 (× 2)	735	1370	32
TF 2004-5	20	4	(3/32) 2.381	20.3	17.8	2.5 × 1 (× 2)	480	1090	35
TF 2005-5		5	(1/8) 3.175	20.5	17.2	2.5 × 1 (× 2)	820	1730	38
TF 2006-5		6	(5/32) 3.969	20.5	16.3	2.5 × 1 (× 2)	1100	2130	39
TF 2504-5		25	4	(3/32) 2.381	25.3	22.8	2.5 × 1 (× 2) 2.5 × 2 (× 2)	525 955	1370 2740
TF 2504-10									
TF 2505-5	5		(1/8) 3.175	25.5	22.2	2.5 × 1 (× 2) 2.5 × 2 (× 2)	910 1650	2180 4370	46 88
TF 2505-10									
TF 2506-5			6	(5/32) 3.969	25.5	21.3	2.5 × 1 (× 2)	1230	2690
TF 2805-5	28	5	(1/8) 3.175	28.5	25.2	2.5 × 1 (× 2) 2.5 × 2 (× 2)	955 1740	2450 4910	50 97
TF 2805-10									
TF 2806-5		6	(5/32) 3.969	28.5	24.3	2.5 × 1 (× 2) 2.5 × 2 (× 2)	1290 2350	3030 6060	51 99
TF 2806-10									
TF 3204-5	32	4	(3/32) 2.381	32.3	29.8	2.5 × 1 (× 2) 2.5 × 2 (× 2)	580 1050	1760 3520	51 98
TF 3204-10									
TF 3205-5		5	(1/8) 3.175	32.5	29.2	2.5 × 1 (× 2) 2.5 × 2 (× 2)	1010 1830	2810 5630	56 108
TF 3205-10									
TF 3206-5			6	(5/32) 3.969	32.5	28.3	2.5 × 1 (× 2) 2.5 × 2 (× 2)	1370 2490	3480 6970
TF 3206-10									



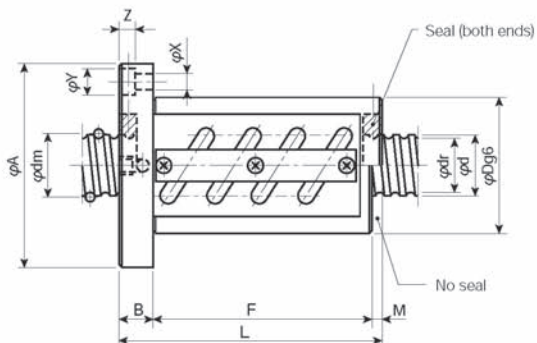

### Remarks

(1) Flange configuration

As shown in Fig. on the left side, two flange configurations R type (standard) and C type are available. Select the correct one according to the space for the nut mounting portion.

(2) Seal

For the type with a seal, the nut length is longer than of the type without a seal by M.

(3) Stiffness

Stiffness shown in Table below is a theoretical value obtained from elastic deformation between the thread groove and steel ball when an axial load is applied, assuming that the preload is 10% of basic rated dynamic load (Ca). It is recommended to use 80% of each value given in Table below.

Unit (mm)

Nut dimensions												Nut type
D	A	G	B	F	L	M	W	X	Y	Z	Q	
40	63	24	11	46	57	0	51	5.5	9.5	5.5	M6	TF 1605-5
40	63	24	11	35	49	3	51	5.5	9.5	5.5	M6	TF 2004-5
44	67	26	11	42	56	3	55	5.5	9.5	5.5	M6	TF 2005-5
48	71	27	11	48	62	3	59	5.5	9.5	5.5	M6	TF 2006-5
46	69	26	11	34	48	3	57	5.5	9.5	5.5	M6	TF 2504-5
				58	72							TF 2504-10
50	73	28	11	41	55	3	61	5.5	9.5	5.5	M6	TF 2505-5
				71	85							TF 2505-10
53	76	29	11	48	62	3	64	5.5	9.5	5.5	M6	TF 2506-5
55	85	31	12	41	56	3	69	6.6	11	6.5	M6	TF 2805-5
				71	86							TF 2805-10
55	85	31	12	48	63	3	69	6.6	11	6.5	M6	TF 2806-5
				84	99							TF 2806-10
54	81	31	12	34	49	3	67	6.6	11	6.5	M6	TF 3204-5
				58	73							TF 3204-10
58	85	32	12	41	56	3	71	6.6	11	6.5	M6	TF 3205-5
				71	86							TF 3205-10
62	89	34	12	48	63	3	75	6.6	11	6.5	M6	TF 3206-5
				84	99							TF 3206-10

# TUBULAR TYPE SINGLE FLANGE SINGLE NUT

TF TYPE (Offset lead preloaded)

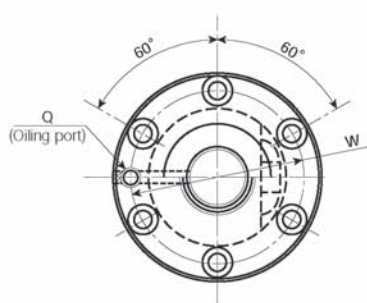

R type (standard)

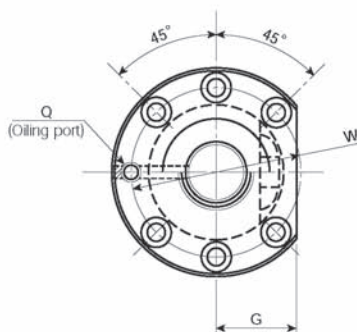

C type

Nut type	Screw O.D $d$	Lead $\ell$	Steel ball dia. $D_a$	Center-circle dia. of steel ball $d_m$	Screw root dia. $d_r$	Number of turns and circuits Turns $\times$ Circ.	Basic rated load (N)		Stiffness (N/ $\mu$ m) $K$
							Dynamic $C_a$	Static $C_{0a}$	
TF 3605-5	36	5	(1/8)	36.5	33.2	2.5 $\times$ 1 ( $\times$ 2)	1060	3170	61
TF 3605-10			3.175			2.5 $\times$ 2 ( $\times$ 2)	1920	6350	118
TF 3606-5		6	(5/32)	36.5	32.3	2.5 $\times$ 1 ( $\times$ 2)	1440	3930	63
TF 3606-10			3.969			2.5 $\times$ 2 ( $\times$ 2)	2620	7870	122
TF 4005-5	40	5	(1/8)	40.5	37.2	2.5 $\times$ 1 ( $\times$ 2)	1110	3530	66
TF 4005-10			3.175			2.5 $\times$ 2 ( $\times$ 2)	2010	7070	129
TF 4006-5		6	(5/32)	40.5	36.3	2.5 $\times$ 1 ( $\times$ 2)	1510	4380	68
TF 4006-10			3.969			2.5 $\times$ 2 ( $\times$ 2)	2740	8770	132

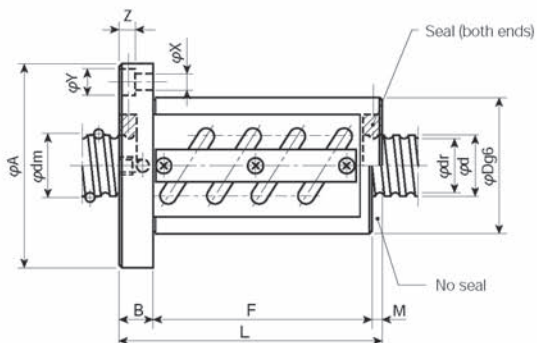

### Remarks

#### (1) Flange configuration

As shown in Fig. on the left side, two flange configurations R type (standard) and C type are available. Select the correct one according to the space for the nut mounting portion.

#### (2) Seal

For the type with a seal, the nut length is longer than of the type without a seal by M.

#### (3) Stiffness

Stiffness shown in Table below is a theoretical value obtained from elastic deformation between the thread groove and steel ball when an axial load is applied, assuming that the preload is 10% of basic rated dynamic load (Ca). It is recommended to use 80% of each value given in Table below.

Unit (mm)

Nut dimensions												Nut type
D	A	G	B	F	L	M	W	X	Y	Z	Q	
65	100	38	15	41	59	3	82	9	14	8.5	M6	TF 3605-5
				71	89							TF 3605-10
65	100	38	15	48	66	3	82	9	14	8.5	M6	TF 3606-5
				84	102							TF 3606-10
67	101	39	15	41	59	3	83	9	14	8.5	PT1/8	TF 4005-5
				71	89							TF 4005-10
70	104	40	15	48	66	3	86	9	14	8.5	PT1/8	TF 4006-5
				84	102							TF 4006-10

# TUBULAR TYPE SINGLE FLANGE DOUBLE NUT

## TD TYPE (Spacer preloaded)

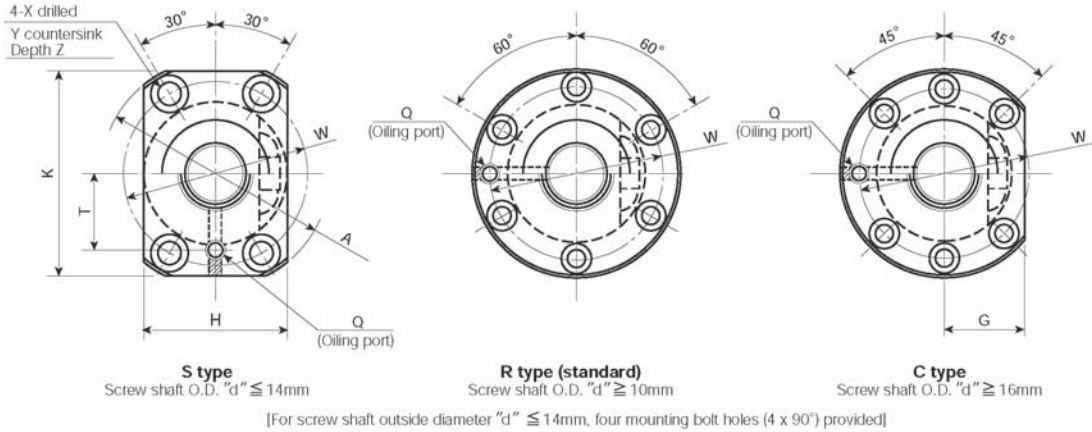

Nut type	Screw O.D.	Lead	Steel ball dia.	Center-circle dia. of steel ball	Screw root dia.	Number of turns and circuits	Basic rated load (N)		Stiffness (N/μm)	
							Dynamic	Static		
	d	ℓ	Da	dm	dr	Turns × Circ.	Ca	Coa	K	
TD 1004-2.5	10	4	2.000	10.3	8.2	2.5 × 1	275	445	20	
TD 1204-2.5	12	4	(3/32) 2.381	12.3	9.8	2.5 × 1	375	635	23	
TD 1205-2.5		5	(3/32) 2.381	12.3	9.8	2.5 × 1	375	635	23	
TD 1404-2.5	14	4	(3/32) 2.381	14.3	11.8	2.5 × 1	405	750	26	
TD 1405-2.5		5	(1/8) 3.175	14.5	11.2	2.5 × 1	685	1190	29	
TD 1604-2.5	16	4	(3/32) 2.381	16.3	13.8	2.5 × 1	435	860	29	
TD 1605-3		5	(1/8) 3.175	16.5	13.2	1.5 × 2	860	1650	38	
TD 1605-2.5			2.5 × 1	735	1370	32				
TD 1605-5			2.5 × 2	1340	2740	62				
TD 1606-3		6	(1/8) 3.175	16.5	13.2	1.5 × 2	860	1650	38	
TD 1606-2.5			2.5 × 1	735	1370	32				
TD 2004-2.5	20	4	(3/32) 2.381	20.3	17.8	2.5 × 1	480	1090	35	
TD 2004-5			2.5 × 2	870	2170	68				
TD 2005-3		5	(1/8) 3.175	20.5	17.2	1.5 × 2	965	2080	45	
TD 2005-2.5			2.5 × 1	820	1730	38				
TD 2005-5			2.5 × 2	1490	3470	74				
TD 2006-3		6	(5/32) 3.969	20.5	16.3	1.5 × 2	1280	2560	46	
TD 2006-2.5			2.5 × 1	1100	2130	39				
TD 2006-5			2.5 × 2	1990	4260	76				
TD 2504-2.5			25	4	(3/32) 2.381	25.3	22.8	2.5 × 1	525	1370
TD 2504-5		2.5 × 2			955	2740	81			
TD 2505-3	5	(1/8) 3.175		25.5	22.2	1.5 × 2	1070	2620	54	
TD 2505-2.5		2.5 × 1		910	2180	46				
TD 2505-5		2.5 × 2		1650	4370	88				
TD 2506-3	6	(5/32) 3.969		25.5	21.3	1.5 × 2	1440	3230	56	
TD 2506-2.5		2.5 × 1		1230	2690	47				
TD 2506-5		2.5 × 2		2230	5390	91				

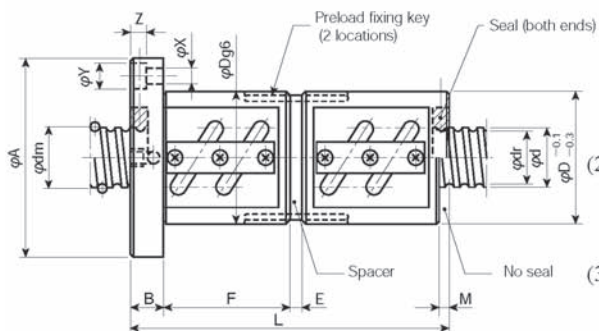

**Remarks**

(1) Flange configuration

As shown in Fig. on the left side, R type (standard) and S type for shaft outside diameters of less than 14mm and R type (standard) and C type for shaft outside diameters of more than 16mm are available. Select the correct one according to the space for the nut mounting portion. The R type with shaft outside diameters of less than 14mm is provided with four mounting bolt holes (4 x 90°).

(2) Seal

For the type with a seal, the nut length is longer than of the type without a seal by M. For the type with shaft outside diameters less than 16mm, the nut has the same length.

(3) Stiffness

Stiffness shown in Table below is a theoretical value obtained from elastic deformation between the thread groove and steel ball when an axial load equivalent to 10% of basic rated dynamic load (Ca) is applied. It is recommended to use 80% of each value given in Table below.

																	Unit (mm)
Nut dimensions																Nut type	
D	A	G	B	F	E	L	M	W	X	Y	Z	Q	T	K	H		
26	46	—	10	24	4	69	0	36	4.5	8	4.5	M6	14	42	28	TD 1004-2.5	
30	50	—	10	24	4	69	0	40	4.5	8	4.5	M6	15	45	32	TD 1204-2.5	
30	50	—	10	28	3	76	0	40	4.5	8	4.5	M6	15	45	32	TD 1205-2.5	
32	55	—	11	24	4	70	0	43	5.5	9.5	5.5	M6	16	50	34	TD 1404-2.5	
34	57	—	11	28	3	77	0	45	5.5	9.5	5.5	M6	17	50	34	TD 1405-2.5	
34	57	22	11	24	4	70	0	45	5.5	9.5	5.5	M6	—	—	—	TD 1604-2.5	
40	63	24	11	28	3	38	0	51	5.5	9.5	5.5	M6	—	—	—	TD 1605-3	
						77										TD 1605-2.5	
						107										TD 1605-5	
40	63	24	11	42	7	110	3	51	5.5	9.5	5.5	M6	—	—	—	TD 1606-3	
				30		86										TD 1606-2.5	
40	63	24	11	23	5	69	3	51	5.5	9.5	5.5	M6	—	—	—	TD 2004-2.5	
				35		93										TD 2004-5	
44	67	26	11	38	4	97	3	55	5.5	9.5	5.5	M6	—	—	—	TD 2005-3	
				27		76										TD 2005-2.5	
				42		106										TD 2005-5	
48	71	27	11	42	7	110	3	59	5.5	9.5	5.5	M6	—	—	—	TD 2006-3	
				30		86										TD 2006-2.5	
				48		133										TD 2006-5	
46	69	26	11	22	6	68	3	57	5.5	9.5	5.5	M6	—	—	—	TD 2504-2.5	
				34		92										TD 2504-5	
50	73	28	11	38	8	102	3	61	5.5	9.5	5.5	M6	—	—	—	TD 2505-3	
				26		75										TD 2505-2.5	
				41		105										TD 2505-5	
53	76	29	11	42	7	110	3	64	5.5	9.5	5.5	M6	—	—	—	TD 2506-3	
				30		86										TD 2506-2.5	
				48		122										TD 2506-5	

# TUBULAR TYPE SINGLE FLANGE DOUBLE NUT

## TD TYPE (Spacer preloaded)

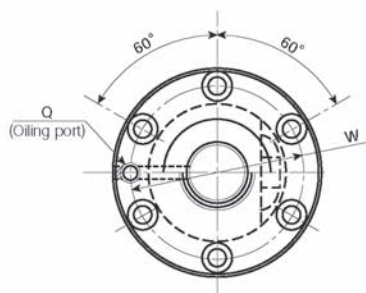

R type (standard)

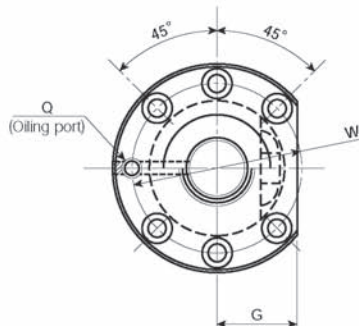

C type

Nut type	Screw O.D <b>d</b>	Lead <b>ℓ</b>	Steel ball dia. <b>Da</b>	Center-circle dia. of steel ball <b>dm</b>	Screw root dia. <b>dr</b>	Number of turns and circuits <b>Turns×Circ.</b>	Basic rated load (N)		Stiffness (N/μm) <b>K</b>
							Dynamic <b>Ca</b>	Static <b>C<sub>0a</sub></b>	
TD 2805-2.5	28	5	(1/8)	28.5	25.2	2.5 × 1	955	2450	50
TD 2805-5			3.175			2.5 × 2	1740	4910	97
TD 2806-2.5		6	(5/32)	28.5	24.3	2.5 × 1	1290	3030	51
TD 2806-5	3.969		2.5 × 2			2350	6060	99	
TD 3204-2.5	32	4	(3/32)	32.3	29.8	2.5 × 1	580	1760	51
TD 3204-5			2.381			2.5 × 2	1050	3520	98
TD 3205-3		5	(1/8)	3.175	32.5	29.2	1.5 × 2	1180	3380
TD 3205-2.5	2.5 × 1						1010	2810	56
TD 3205-5	6	(5/32)	3.969	32.5	28.3	2.5 × 2	1830	5630	108
TD 3206-3						1.5 × 2	1610	4180	68
TD 3206-2.5						2.5 × 1	1370	3480	57
TD 3206-5	5	(1/8)	3.175	36.5	33.2	2.5 × 2	2490	6970	111
TD 3605-2.5						2.5 × 1	1060	3170	61
TD 3605-5	36	6	(5/32)	36.5	32.3	2.5 × 2	1920	6350	118
TD 3606-2.5			2.5 × 1			1440	3930	63	
TD 3606-5		2.5 × 2	2620	7870	122				
TD 4005-3	40	5	(1/8)	40.5	37.2	1.5 × 2	1300	4240	79
TD 4005-2.5						2.5 × 1	1110	3530	66
TD 4005-5						2.5 × 2	2010	7070	129
TD 4005-7.5	6	(5/32)	3.969	40.5	36.3	2.5 × 3	2870	10600	190
TD 4006-3						1.5 × 2	1770	5260	81
TD 4006-2.5	2.5 × 1	2.5 × 2	2740	8770	132	1510	4380	68	
TD 4006-5						2740	8770	132	
TD 4006-7.5						3910	13100	195	

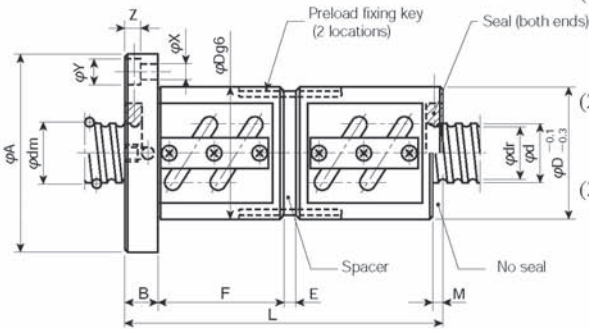

### Remarks

#### (1) Flange configuration

As shown in Fig. on the left side, two flange configurations R type (standard) and C type are available. Select the correct one according to the space for the nut mounting portion.

#### (2) Seal

For the type with a seal, the nut length is longer than of the type without a seal by M.

#### (3) Stiffness

Stiffness shown in Table below is a theoretical value obtained from elastic deformation between the thread groove and steel ball when an axial load equivalent to 10% of basic rated dynamic load (Ca) is applied. It is recommended to use 80% of each value given in Table below.

Unit (mm)

Nut dimensions													Nut type
D	A	G	B	F	E	L	M	W	X	Y	Z	Q	
55	85	31	12	26	5	76	3	69	6.6	11	6.5	M6	TD 2805-2.5
				41		106							TD 2805-5
55	85	31	12	30	7	87	3	69	6.6	11	6.5	M6	TD 2806-2.5
				48		123							TD 2806-5
54	81	31	12	22	6	69	3	67	6.6	11	6.5	M6	TD 3204-2.5
				34		93							TD 3204-5
58	85	32	12	38	8	103	3	71	6.6	11	6.5	M6	TD 3205-3
				26		5							76
58	85	32	12	41	5	106	3	71	6.6	11	6.5	M6	TD 3205-5
				42		111							TD 3206-3
62	89	34	12	30	7	87	3	75	6.6	11	6.5	M6	TD 3206-2.5
				48		123							TD 3206-5
65	100	38	15	26	5	78	7	82	9	14	8.5	M6	TD 3605-2.5
				41		109							TD 3605-5
65	100	38	15	30	7	90	3	82	9	14	8.5	M6	TD 3606-2.5
				48		126							TD 3606-5
67	101	39	15	38	8	106	3	83	9	14	8.5	PT1/8	TD 4005-3
				26		5							79
67	101	39	15	41	5	109	3	83	9	14	8.5	PT1/8	TD 4005-5
				56		5							138
70	104	40	15	42	7	114	3	86	9	14	8.5	PT1/8	TD 4006-3
				30		5							90
70	104	40	15	48	7	126	3	86	9	14	8.5	PT1/8	TD 4006-5
				66		162							TD 4006-7.5

# TUBULAR TYPE HIGH LEAD SINGLE FLANGE SINGLE NUT

## TCL TYPE (Non-preloaded)

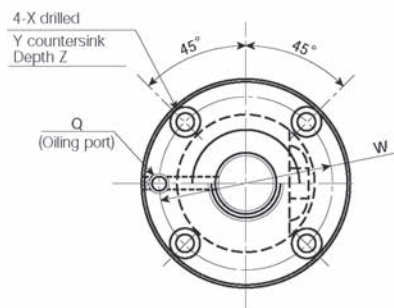

R type (standard)

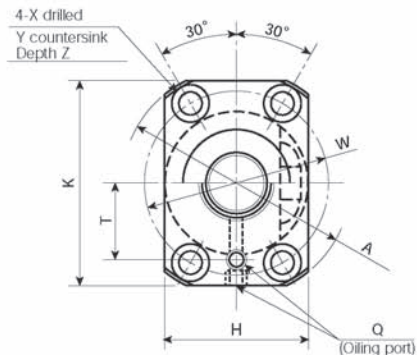

S type

Nut type	Screw O.D	Lead	Steel ball dia.	Center-circle dia. of steel ball	Screw root dia.	Number of turns and circuits	Basic rated load (N)		Stiffness (N/μm)
	d						Dynamic Ca	Static Coa	
TCL 1206-2.5	12	6	(3/32) 2.381	12.5	10.0	2.5 × 1	380	630	12
TCL 1208-2.5		8	(3/32) 2.381	12.5	10.0	2.5 × 1	380	630	12
TCL 1210-2.5		10	(3/32) 2.381	12.5	10.0	2.5 × 1	380	630	12
TCL 1216-1.5		16	(3/32) 2.381	12.5	10.0	1.5 × 1	240	350	7.1
TCL 1220-1.5		20	(3/32) 2.381	12.5	10.0	1.5 × 1	240	350	7.1
TCL 1410-1.5	14	10	(1/8)	14.5	11.2	1.5 × 1	685	1170	14
TCL 1410-2.5			2.5 × 1						
TCL 1510-1.5	15	10	(1/8)	15.5	12.2	1.5 × 1	710	1260	15
TCL 1510-2.5			2.5 × 1						
TCL 1810-1.5	18	10	(1/8)	18.5	15.2	1.5 × 1	780	1540	18
TCL 1810-2.5			2.5 × 1						
TCL 2012-1.5	20	12	(1/8)	20.5	17.2	1.5 × 1	705	1260	12
TCL 2012-2.5			2.5 × 1						
TCL 2020-1.5		20	(5/32) 3.969	21.0	16.8	1.5 × 1	705	1260	12



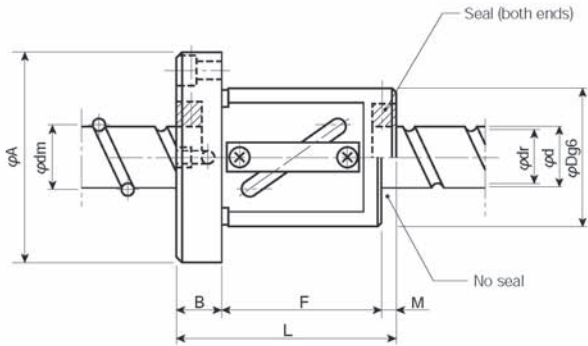

### Remarks

- (1) Flange configuration  
As shown in Fig. on the left side, two flange configurations R type (standard) and S type are available. Select the correct one according to the space for the nut mounting portion.
- (2) Seal  
For the type with a seal, the nut length is longer than of the type without a seal by M.
- (3) Stiffness  
Stiffness shown in Table below is a theoretical value obtained from elastic deformation between the thread groove and steel ball when an axial load equivalent to 30% of basic rated dynamic load (Ca) is applied. It is recommended to use 80% of each value given in Table below.

Unit (mm)

Nut dimensions													Nut type	
D	A	B	F	L	M	W	X	Y	Z	Q	T	K	H	
30	50	10	30	40	0	40	4.5	8	4.5	M6	15	45	32	TCL 1206-2.5
30	50	10	35	45	0	40	4.5	8	4.5	M6	15	45	32	TCL 1208-2.5
30	50	10	40	50	0	40	4.5	8	4.5	M6	15	45	32	TCL 1210-2.5
30	50	10	44	54	0	40	4.5	8	4.5	M6	15	45	32	TCL 1216-1.5
30	50	10	50	60	0	40	4.5	8	4.5	M6	15	45	32	TCL 1220-1.5
34	57	11	29	44	4	45	5.5	9.5	5.5	M6	17	50	34	TCL 1410-1.5
			41	56										TCL 1410-2.5
34	57	11	31	46	4	45	5.5	9.5	5.5	M6	17	50	34	TCL 1510-1.5
			39	54										TCL 1510-2.5
42	65	11	31	46	4	53	5.5	9.5	5.5	M6	21	58	42	TCL 1810-1.5
			39	54										TCL 1810-2.5
44	67	12	33	49	4	55	5.5	9.5	5.5	M6	22	60	44	TCL 2012-1.5
			45	61										TCL 2012-2.5
46	74	15	47	70	8	59	6.6	11	6.5	M6	24	66	46	TCL 2020-1.5

# TUBULAR TYPE HIGH LEAD SINGLE FLANGE SINGLE NUT

## TPL TYPE (Oversize ball preloaded)

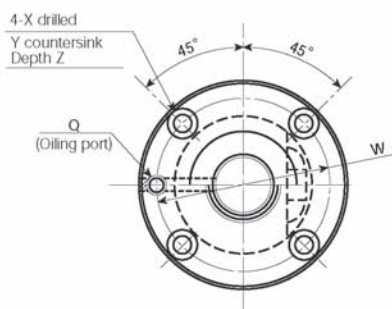

R type (standard)

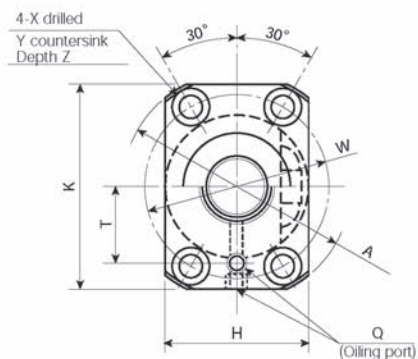

S type

Nut type	Screw O.D <b>d</b>	Lead <b>ℓ</b>	Steel ball dia. <b>Da</b>	Center-circle dia. of steel ball <b>dm</b>	Screw root dia. <b>dr</b>	Number of turns and circuits <b>Turns × Circ.</b>	Basic rated load (N)		Stiffness (N/μm) <b>K</b>
							Dynamic <b>Ca</b>	Static <b>Ca0</b>	
TPL 1206-2.5	12	6	(3/32) 2.381	12.5	10.0	2.5 × 1	380	630	12
TPL 1208-2.5		8	(3/32) 2.381	12.5	10.0	2.5 × 1	380	630	12
TPL 1210-2.5		10	(3/32) 2.381	12.5	10.0	2.5 × 1	380	630	12
TPL 1216-1.5		16	(3/32) 2.381	12.5	10.0	1.5 × 1	240	350	7.1
TPL 1220-1.5		20	(3/32) 2.381	12.5	10.0	1.5 × 1	240	350	7.1
TPL 1410-1.5	14	10	(1/8)	14.5	11.2	1.5 × 1	685	1170	14
TPL 1410-2.5			3.175			2.5 × 1			
TPL 1510-1.5	15	10	(1/8)	15.5	12.2	1.5 × 1	710	1260	15
TPL 1510-2.5			3.175			2.5 × 1			
TPL 1810-1.5	18	10	(1/8)	18.5	15.2	1.5 × 1	780	1540	18
TPL 1810-2.5			3.175			2.5 × 1			
TPL 2012-1.5	20	12	(1/8)	20.5	17.2	1.5 × 1	705	1260	12
TPL 2012-2.5			3.175			2.5 × 1			
TPL 2020-1.5		20	(5/32) 3.969	21.0	16.8	1.5 × 1	705	1260	12

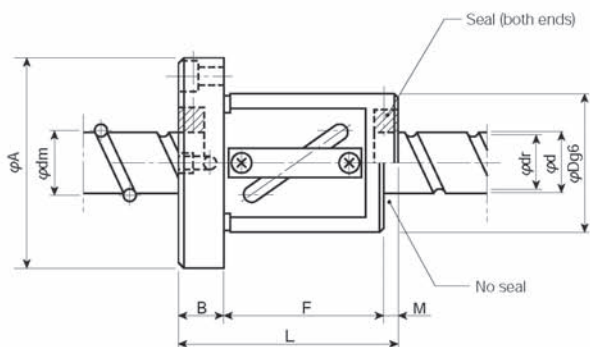

### Remarks

- (1) Flange configuration  
As shown in Fig. on the left side, two flange configurations R type (standard) and S type are available. Select the correct one according to the space for the nut mounting portion.
- (2) Seal  
For the type with a seal, the nut length is longer than of the type without a seal by M.
- (3) Basic rated load  
Since the ratio of load balls to spacer balls put in the nut is 1:1, the basic rated load of this type differs from that of non-preloaded.
- (4) Stiffness  
Stiffness shown in Table below is a theoretical value obtained from elastic deformation between the thread groove and steel ball when an axial load is applied, assuming that the preload is 5% of basic rated dynamic load (Ca). It is recommended to use 80% of each value given in Table below.

Unit (mm)

Nut dimensions														Nut type
D	A	B	F	L	M	W	X	Y	Z	Q	T	K	H	
30	50	10	30	40	0	40	4.5	8	4.5	M6	15	45	32	TPL 1206-2.5
30	50	10	35	45	0	40	4.5	8	4.5	M6	15	45	32	TPL 1208-2.5
30	50	10	40	50	0	40	4.5	8	4.5	M6	15	45	32	TPL 1210-2.5
30	50	10	44	54	0	40	4.5	8	4.5	M6	15	45	32	TPL 1216-1.5
30	50	10	50	60	0	40	4.5	8	4.5	M6	15	45	32	TPL 1220-1.5
34	57	11	29 41	44 56	4	45	5.5	9.5	5.5	M6	17	50	34	TPL 1410-1.5 TPL 1410-2.5
34	57	11	31 39	46 54	4	45	5.5	9.5	5.5	M6	17	50	34	TPL 1510-1.5 TPL 1510-2.5
42	65	11	31 39	46 54	4	53	5.5	9.5	5.5	M6	21	58	42	TPL 1810-1.5 TPL 1810-2.5
44	67	12	33 45	49 61	4	55	5.5	9.5	5.5	M6	22	60	44	TPL 2012-1.5 TPL 2012-2.5
46	74	15	47	70	8	59	6.6	11	6.5	M6	24	66	46	TPL 2020-1.5

# DEFLECTOR TYPE SINGLE FLANGE SINGLE NUT

KC TYPE (Non-preloaded)

KP TYPE (Oversize ball preloaded)

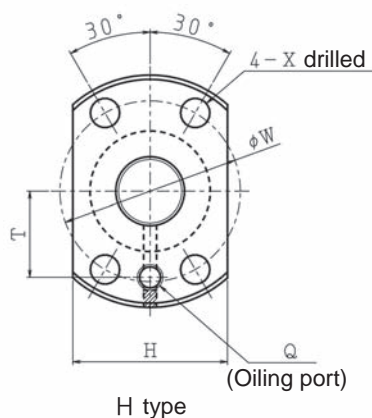

P/N	Screw O.D. d	Lead ℓ	Ball dia. Da	Ball circle dia. dm	Screw root dia. dr	Number of turns & circuits Turns×Circ.	Basic rated load (daN)		Stiffness (daN/μm) K
							Dynamic Ca	Static C <sub>0a</sub>	
KC 0601-3 KP 0601-3	6	1	0.800	6.2	5.4	1×3	63	105	6.5 11
KC 0801-3 KP 0801-3	8	1	0.800	8.2	7.4	1×3	70	145	8.1 13
KC 0802-3 KP 0802-3	8	2	1.200	8.3	7.0	1×3	125	215	8.7 14
KC 1002-3 KP 1002-3	10	2	1.200	10.3	9.0	1×3	135	265	10 17
KC 1202-3 KP 1202-3	12	2	1.200	12.3	11.0	1×3	145	320	12 20
KC 1404-3 KP 1404-3	14	4	(3/32) 2.381	14.65	12.2	1×3	480	925	16 26
KC 1602-4 KP 1602-4	16	2	1.200	16.3	15.0	1×4	250	715	21 34
KC 1602.5-4 KP 1602.5-4	16	2.5	2.000	16.3	14.2	1×4	510	1170	22 37

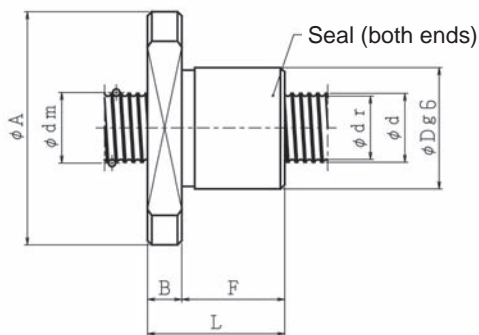

Remarks

(1) Flange Configuration

As shown in Fig. on the left side, normally H type is available.

If another type is needed, please let us know.

Oiling port is provided to the screw O.D. 16mm and over.

(2) Stiffness

Stiffness shown in Table below is, in case of non-preloaded, a theoretical value obtained from elastic deformation between the thread groove and steel ball when an axial load equivalent to 30% of basic rated dynamic load (Ca) is applied. In case of preloaded, it is shown as a theoretical value obtained from elastic deformation between the thread groove and steel ball when axial load is applied, assuming that the preload is 5% of basic rated dynamic load (Ca). It is recommended to use 80% of each value given in Table below.

												Unit (mm)
Nut dimensions											P/N	
D	A	B	F	L	W	X	Y	Z	Q	T	H	
12	24	3.5	11.5	15	18	3.4	—	—	—	—	16	KC 0601-3 KP 0601-3
14	27	4	12	16	21	3.4	—	—	—	—	18	KC 0801-3 KP 0801-3
16	28	4	22	26	23	3.4	—	—	—	—	20	KC 0802-3 KP 0802-3
18	35	5	23	28	27	4.5	—	—	—	—	22	KC 1002-3 KP 1002-3
20	37	5	23	28	29	4.5	—	—	—	—	24	KC 1202-3 KP 1202-3
26	45	6	27	33	36	5.5	—	—	—	—	28	KC 1404-3 KP 1404-3
25	44	10	30	40	35	5.5	—	—	M6	16	29	KC 1602-4 KP 1602-4
25	44	10	34	44	35	5.5	—	—	M6	16	29	KC 1602.5-4 KP 1602.5-4

(Ref) SI unit system 1daN=10N ≒ 1.02kgf

# END DEFLECTOR TYPE SINGLE FLANGE SINGLE NUT

EC TYPE (Non-preloaded)

EP TYPE (Oversize ball preloaded)

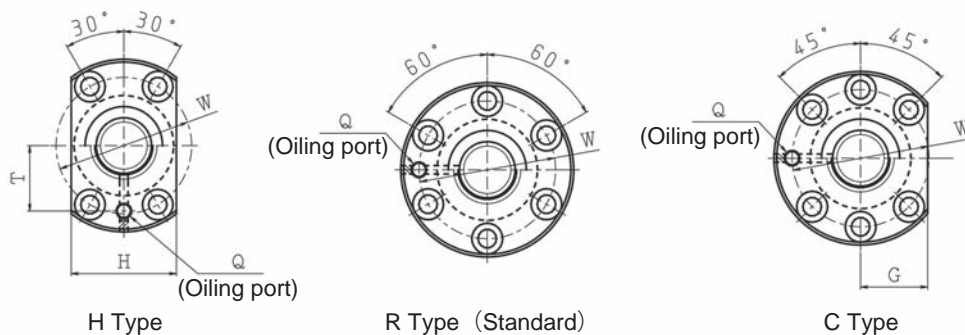

P/N	Screw O.D. d	Lead ℓ	Ball dia. Da	Ball circle dia. dm	Screw root dia. dr	Number of turns & circuits Turns×Circ.	Basic rated load (daN)		Stiffness (daN/μm) K
							Dynamic Ca	Static C <sub>0a</sub>	
EC 1210-2.7 EP 1210-2.7	12	10	2.000	12.5	10.0	2.7 × 1	320	585	12 20
EC 1505-2.7 EP 1505-2.7	15	5	(3/32) 2.381	15.3	12.8	2.7 × 1	450	870	15 24
EC 1520-1.7 EP 1520-1.7	15	20	(1/8) 3.175	15.5	12.2	1.7 × 1	505	875	10 17
EC 1605-2.7 EP 1605-2.7	16	5	(1/8) 3.175	16.5	13.2	2.7 × 1	785	1480	17 28
EC 2010-2.7 EP 2010-2.7	20	10	(1/8) 3.175	20.5	17.2	2.7 × 1	880	1850	20 34
EC 2510-3.7 EP 2510-3.7	25	10	(1/8) 3.175	25.5	22.2	3.7 × 1	1280	3230	33 55

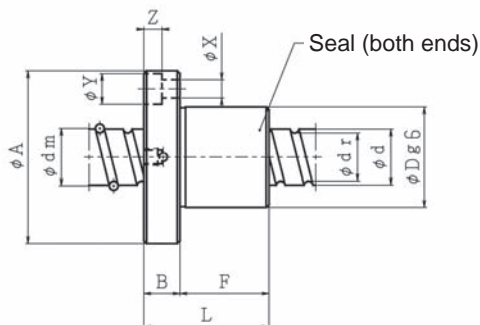

Remarks

(1) Flange Configuration

As shown in Fig. on the left side, R type (standard) and S type for shaft outside diameters of 15mm and less and R type (standard) and C type for shaft outside diameters of 16mm and over are available. Select the correct one according to the space for the nut mounting portion. The R type with shaft outside diameters of 15mm and less is provided with four mounting bolt holes (4 × 90°).

(2) Stiffness

Stiffness shown in Table below is, in case of non-preloaded, a theoretical value obtained from elastic deformation between the thread groove and steel ball when an axial load equivalent to 30% of basic rated dynamic load (Ca) is applied. In case of preloaded, it is shown as a theoretical value obtained from elastic deformation between the thread groove and steel ball when axial load is applied, assuming that the preload is 5% of basic rated dynamic load (Ca). It is recommended to use 80% of each value given in Table below.

													Unit (mm)
Nut dimensions													P/N
D	A	G	B	F	L	W	X	Y	Z	Q	T	H	
24	44	—	11	32	43	34	4.5	8	4.5	M6	14.5	27	EC 1210-2.7 EP 1210-2.7
28	51	—	11	19	30	39	5.5	9.5	5.5	M6	18	32	EC 1505-2.7 EP 1505-2.7
32	55	—	11	40	51	43	5.5	9.5	5.5	M6	20	34	EC 1520-1.7 EP 1520-1.7
30	49	—	10	20	30	39	4.5	8	4.5	M6	17	31	EC 1605-2.7 EP 1605-2.7
36	62	24	13	32	45	49	6.6	11	6.5	M6	—	—	EC 2010-2.7 EP 2010-2.7
40	62	24	12	44	56	51	6.6	—	—	M6	—	—	EC 2510-3.7 EP 2510-3.7

(Ref) SI unit system 1daN=10N ≙ 1.02kgf

# 11. NIDEC SANKYO BALLSCREW STANDARD STOCK LIST

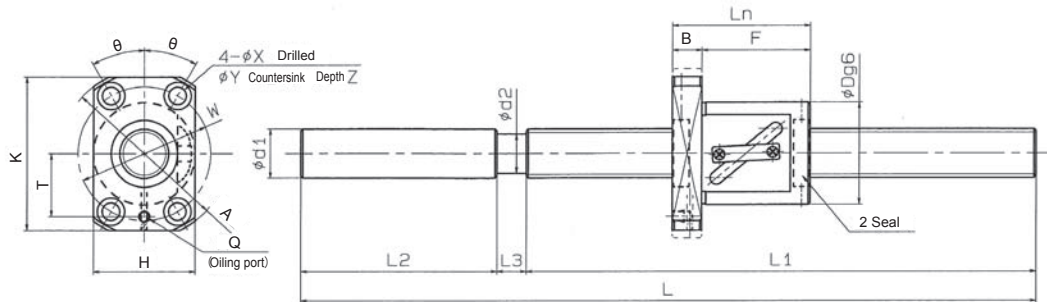

No.	P/N	Screw O.D. d	Lead $\ell$	Ball dia. Da	Number of turns of balls Turns×Circ.	Basic rated load (daN)		Shaft dimensions					
						Dynamic Ca	Static COa	L	L1	L2	L3	d1	d2
1	BS0802BIS-C5T-111R160	8	2	1.588	2.5×1	180	250	160	111	45	4	12	6.4
2	BS0802BIS-C5T-166R215	8	2	1.588	2.5×1	180	250	215	166	45	4	12	6.4
3	BS0804BIS-C5T-159R210	8	4	2.000	2.5×1	240	350	210	159	45	6	12	6
4	BS0804BIS-C5T-249R300	8	4	2.000	2.5×1	240	350	300	249	45	6	12	6
5	BS0805BIS-C5T-160R210	8	5	2.000	2.5×1	240	350	210	160	45	5	12	6
6	BS0805BIS-C5T-290R340	8	5	2.000	2.5×1	240	350	340	290	45	5	12	6
7	BS0808AIS-C5T-157R210	8	8	2.000	1.5×1	155	210	210	157	45	8	12	6
8	BS0808AIS-C5T-247R300	8	8	2.000	1.5×1	155	210	300	247	45	8	12	6
9	BS0810AIS-C5T-157R210	8	10	2.000	1.5×1	155	210	210	157	45	8	12	6
10	BS0810AIS-C5T-287R340	8	10	2.000	1.5×1	155	210	340	287	45	8	12	6
11	BS1002BIS-C5T-201R250	10	2	1.588	2.5×1	200	360	250	201	45	4	10	8.4
12	BS1002BIS-C5T-351R400	10	2	1.588	2.5×1	200	360	400	351	45	4	10	8.4
13	BS1004BIS-C5T-190R250	10	4	2.000	2.5×1	275	445	250	190	55	5	12	8
14	BS1004BIS-C5T-395R455	10	4	2.000	2.5×1	275	445	455	395	55	5	12	8
15	BS1010AIS-C5T-192R255	10	10	2.000	1.5×1	175	265	255	192	55	8	14	8
16	BS1010AIS-C5T-437R500	10	10	2.000	1.5×1	175	265	500	437	55	8	14	8
17	BS1202BIS-C5T-340R400	12	2	1.588	2.5×1	220	435	400	340	55	5	12	10.4
18	BS1204BIS-C5T-345R405	12	4	2.381	2.5×1	375	635	405	345	55	5	12	9.6
19	BS1204BIS-C5T-540R600	12	4	2.381	2.5×1	375	635	600	540	55	5	12	9.6
20	BS1205BIS-C5T-240R300	12	5	2.381	2.5×1	375	635	300	240	55	5	12	9.6
21	BS1205BIS-C5T-395R455	12	5	2.381	2.5×1	375	635	455	395	55	5	12	9.6
22	BS1210BIS-C5T-240R300	12	10	2.381	2.5×1	380	630	300	240	55	5	12	9.8
23	BS1210BIS-C5T-395R455	12	10	2.381	2.5×1	380	630	455	395	55	5	12	9.8
24	BS1210BIS-C5T-540R600	12	10	2.381	2.5×1	380	630	600	540	55	5	12	9.8
25	BS1220AIS-C5T-335R400	12	20	2.381	1.5×1	240	350	400	335	55	10	12	9.8
26	BS1220AIS-C5T-535R600	12	20	2.381	1.5×1	240	350	600	535	55	10	12	9.8
27	BS1504BIS-C5T-540R600	15	4	2.381	2.5×1	420	805	600	540	55	5	15	12.6
28	BS1504BIS-C5T-1040R1100	15	4	2.381	2.5×1	420	805	1100	1040	55	5	15	12.6
29	BS1505BIS-C5T-390R450	15	5	3.175	2.5×1	710	1280	450	390	55	5	15	12
30	BS1505BIS-C5T-540R600	15	5	3.175	2.5×1	710	1280	600	540	55	5	15	12
31	BS1505BIS-C5T-1040R1100	15	5	3.175	2.5×1	710	1280	1100	1040	55	5	15	12
32	BS1510BIS-C5T-390R450	15	10	3.175	2.5×1	710	1260	450	390	55	5	15	12
33	BS1510BIS-C5T-540R600	15	10	3.175	2.5×1	710	1260	600	540	55	5	15	12
34	BS1510BIS-C5T-1040R1100	15	10	3.175	2.5×1	710	1260	1100	1040	55	5	15	12
35	BS1520AIS-C5T-385R450	15	20	3.175	1.5×1	455	770	450	385	55	10	15	12
36	BS1520AIS-C5T-535R600	15	20	3.175	1.5×1	455	770	600	535	55	10	15	12
37	BS1520AIS-C5T-1035R1100	15	20	3.175	1.5×1	455	770	1100	1035	55	10	15	12
38	BS1530-2N-A2S-C5T-533R600	15	30	3.175	1.5×2	840	1540	600	533	55	12	15	12
39	BS1530-2N-A2S-C5T-1033R1100	15	30	3.175	1.5×2	840	1540	1100	1033	55	12	15	12
40	BS2005BIS-C5T-520R600	20	5	3.175	2.5×1	820	1730	600	520	75	5	20	17
41	BS2005BIS-C5T-1020R1100	20	5	3.175	2.5×1	820	1730	1100	1020	75	5	20	17
42	BS2010BIS-C5T-517R600	20	10	3.969	2.5×1	1110	2170	600	517	75	8	20	16
43	BS2010BIS-C5T-1017R1100	20	10	3.969	2.5×1	1110	2170	1100	1017	75	8	20	16
44	BS2020AIS-C5T-515R600	20	20	3.969	1.5×1	705	1260	600	515	75	10	20	16
45	BS2020AIS-C5T-1015R1100	20	20	3.969	1.5×1	705	1260	1100	1015	75	10	20	16
46	BS2505BIS-C5T-495R600	25	5	3.175	2.5×1	910	2180	600	495	100	5	25	22
47	BS2505BIS-C5T-995R1100	25	5	3.175	2.5×1	910	2180	1100	995	100	5	25	22
48	BS2510BIS-C5T-492R600	25	10	3.969	2.5×1	1240	2740	600	492	100	8	25	21
49	BS2510BIS-C5T-992R1100	25	10	3.969	2.5×1	1240	2740	1100	992	100	8	25	21
50	BS2520AIS-C5T-990R1100	25	20	3.969	1.5×1	790	1610	1100	990	100	10	25	21



(Specification & notice)

- (1) Accuracy Grade      JIS C5
- (2) Axial Clearance      under 0.005mm
- (3) Material              Shaft & Nut: SCM415H
- (4) The oil for preventing rust is put to the ballscrew when delivered.

Please lubricate grease or oil by customer side when use the ballscrew.

Unit (mm)

D	Ln	B	F	Nut dimensions									T	Q
				A	θ	W	X	Y	Z	H	K			
20	30	5	25	36	45	27	3.4	6.5	3.3	28	28	-	-	
20	30	5	25	36	45	27	3.4	6.5	3.3	28	28	-	-	
22	30	5	25	38	30	29	3.4	6.5	3.3	24	34	-	-	
22	30	5	25	38	30	29	3.4	6.5	3.3	24	34	-	-	
24	36	8	28	44	30	34	4.5	8	4.4	27	40	-	-	
24	36	8	28	44	30	34	4.5	8	4.4	27	40	-	-	
24	35	8	27	44	30	34	4.5	8	4.4	27	40	-	-	
24	35	8	27	44	30	34	4.5	8	4.4	27	40	-	-	
24	35	8	27	44	30	34	4.5	8	4.4	27	40	-	-	
24	35	8	27	44	30	34	4.5	8	4.4	27	40	-	-	
23	27	5	22	40	45	31	4.5	-	-	31	31	-	-	
23	27	5	22	40	45	31	4.5	-	-	31	31	-	-	
26	37	8	29	46	30	36	4.5	8	4.4	28	42	-	-	
26	37	8	29	46	30	36	4.5	8	4.4	28	42	-	-	
28	42	10	32	46	30	36	4.5	8	4.4	28	42	14	M6×1.0	
28	42	10	32	46	30	36	4.5	8	4.4	28	42	14	M6×1.0	
25	35	8	27	44	45	33	4.5	8	4.4	34	34	-	-	
30	41	10	31	54	45	41	5.5	9.5	5.4	41	41	15	M6×1.0	
30	41	10	31	54	45	41	5.5	9.5	5.4	41	41	15	M6×1.0	
30	44	10	34	50	30	40	4.5	8	4.4	32	45	15	M6×1.0	
30	44	10	34	50	30	40	4.5	8	4.4	32	45	15	M6×1.0	
30	49	12	37	54	30	41	5.5	9.5	5.4	32	48	16	M6×1.0	
30	49	12	37	54	30	41	5.5	9.5	5.4	32	48	16	M6×1.0	
30	49	12	37	54	30	41	5.5	9.5	5.4	32	48	16	M6×1.0	
32	68	12	56	56	30	43	5.5	9.5	5.4	32	48	16	M6×1.0	
32	68	12	56	56	30	43	5.5	9.5	5.4	32	48	16	M6×1.0	
32	41	10	31	56	30	43	5.5	9.5	5.4	32	48	18	M6×1.0	
32	41	10	31	56	30	43	5.5	9.5	5.4	32	48	18	M6×1.0	
34	44	10	34	58	30	45	5.5	9.5	5.4	34	50	18	M6×1.0	
34	44	10	34	58	30	45	5.5	9.5	5.4	34	50	18	M6×1.0	
34	44	10	34	58	30	45	5.5	9.5	5.4	34	50	18	M6×1.0	
34	52	12	40	58	30	45	5.5	9.5	5.4	34	50	18	M6×1.0	
34	52	12	40	58	30	45	5.5	9.5	5.4	34	50	18	M6×1.0	
34	52	12	40	58	30	45	5.5	9.5	5.4	34	50	18	M6×1.0	
34	62	12	50	58	30	45	5.5	9.5	5.4	34	50	18	M6×1.0	
34	62	12	50	58	30	45	5.5	9.5	5.4	34	50	18	M6×1.0	
34	62	12	50	58	30	45	5.5	9.5	5.4	34	50	18	M6×1.0	
34	80	12	68	58	30	45	5.5	9.5	5.4	34	50	18	M6×1.0	
34	80	12	68	58	30	45	5.5	9.5	5.4	34	50	18	M6×1.0	
40	48	12	36	68	30	53	6.6	11	6.5	40	60	22	M6×1.0	
40	48	12	36	68	30	53	6.6	11	6.5	40	60	22	M6×1.0	
46	65	15	50	74	30	59	6.6	11	6.5	46	66	24	M6×1.0	
46	65	15	50	74	30	59	6.6	11	6.5	46	66	24	M6×1.0	
46	70	15	55	74	30	59	6.6	11	6.5	46	66	24	M6×1.0	
46	70	15	55	74	30	59	6.6	11	6.5	46	66	24	M6×1.0	
47	48	12	36	74	45	60	6.6	11	6.5	57	57	-	M6×1.0	
47	48	12	36	74	45	60	6.6	11	6.5	57	57	-	M6×1.0	
52	65	15	50	86	30	68	9	14	8.6	52	78	30	M6×1.0	
52	65	15	50	86	30	68	9	14	8.6	52	78	30	M6×1.0	
52	70	15	55	86	30	68	9	14	8.6	52	78	30	M6×1.0	

# 12. SHAFT END MACHINING SERIES

- (1) Attached drawing shows Sankyo standard shaft end specification.
- (2) Customized shaft end machining is also available.

Screw O.D.	8
Lead	2
Overall length	~ 215mm
Grade	C3 or C5

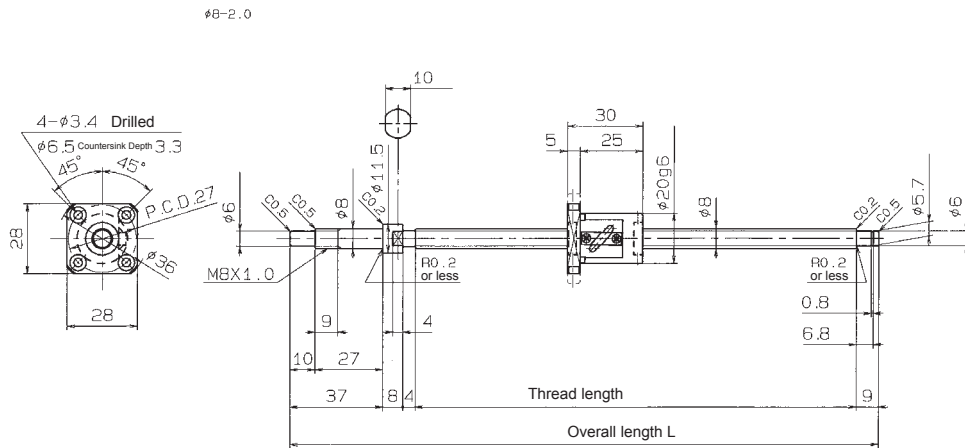

Unit (mm)

P/N	Axial clearance	Screw O.D. <i>d</i>	Lead <i>ℓ</i>	Overall length <i>L</i>	Ball dia. <i>Da</i>	Ball circle dia. <i>dm</i>	Screw root dia. <i>dr</i>	Number of turns & circuits Turns×Circ.	Basic rated load (daN)		Stiffness (daN/μm) <i>K</i>	Torque (daN·cm)
									Dynamic <i>Ca</i>	Static <i>Coa</i>		
BS0802-160	0	8	2	160 or less	1.588	8.3	6.6	2.5×1	115	145	7.0	0.02 ~ 0.10
	0.005 or less								180	250	7.9	—
BS0802-215	0	8	5	215 or less	1.588	8.3	6.6	2.5×1	115	145	7.0	0.02 ~ 0.10
	0.005 or less								180	250	7.9	—

- (1) Attached drawing shows Sankyo standard shaft end specification.  
 (2) Customized shaft end machining is also available.

Screw O.D.	8
Lead	4
Overall length	~ 300mm
Grade	C3 or C5

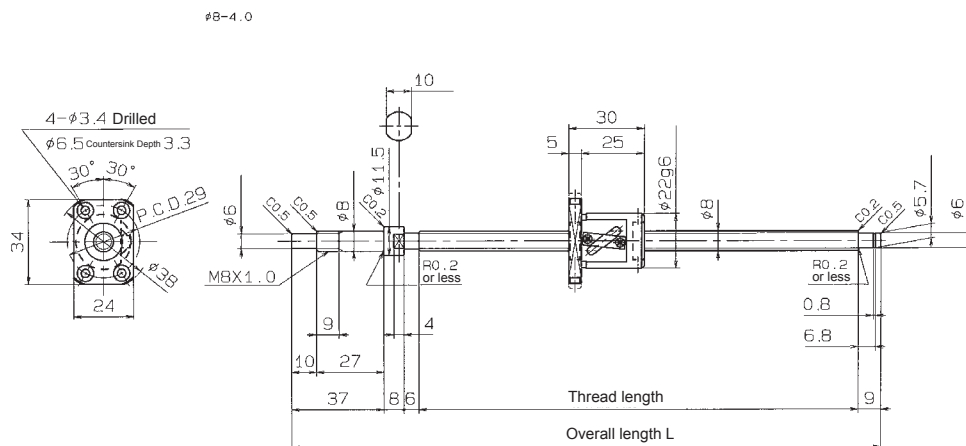

Unit (mm)

P/N	Axial clearance	Screw O.D. <i>d</i>	Lead <i>ℓ</i>	Overall length <i>L</i>	Ball dia. <i>Da</i>	Ball circle dia. <i>dm</i>	Screw root dia. <i>dr</i>	Number of turns & circuits Turns×Circ.	Basic rated load (daN)		Stiffness (daN/μm) <i>K</i>	Torque (daN·cm)
									Dynamic <i>Ca</i>	Static <i>Coa</i>		
BS0804-210	0	8	4	210 or less	2.000	8.3	6.2	2.5×1	150	175	7.1	0.02 ~ 0.12
	0.005 or less								240	350	8.0	—
BS0804-300	0	8	4	300 or less	2.000	8.3	6.2	2.5×1	150	175	7.1	0.02 ~ 0.12
	0.005 or less								240	350	8.0	—



- (1) Attached drawing shows Sankyo standard shaft end specification.  
 (2) Customized shaft end machining is also available.

Screw O.D.	8
Lead	8
Overall length	~ 300mm
Grade	C3 or C5

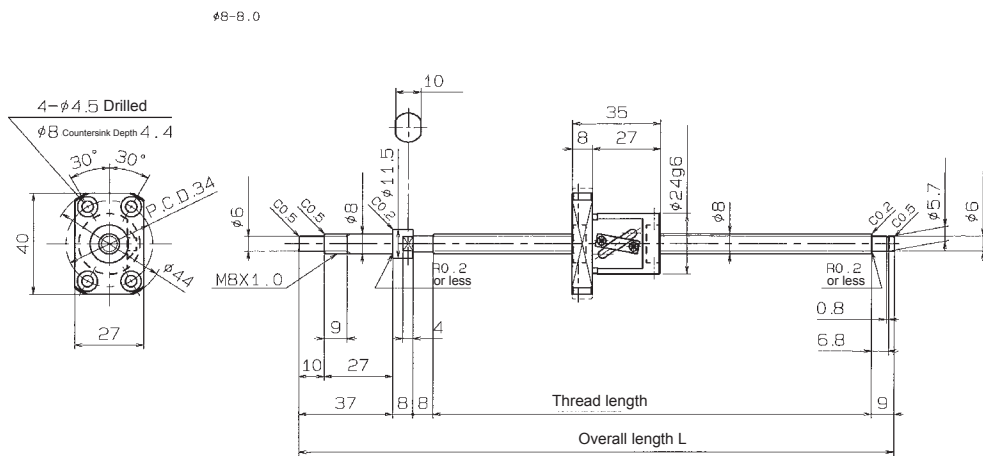

Unit (mm)

P/N	Axial clearance	Screw O.D. <i>d</i>	Lead <i>ℓ</i>	Overall length <i>L</i>	Ball dia. <i>Da</i>	Ball circle dia. <i>dm</i>	Screw root dia. <i>dr</i>	Number of turns & circuits Turns×Circ.	Basic rated load (daN)		Stiffness (daN/μm) <i>K</i>	Torque (daN·cm)
									Dynamic <i>Ca</i>	Static <i>Coa</i>		
BS0808-210	0	8	8	210 or less	2.000	8.3	6.2	1.5×1	95	100	4.2	0.02 ~ 0.12
	0.005 or less								155	210	4.9	—
BS0808-300	0	8	8	300 or less	2.000	8.3	6.2	1.5×1	95	100	4.2	0.02 ~ 0.12
	0.005 or less								155	210	4.9	—



- (1) Attached drawing shows Sankyo standard shaft end specification.  
 (2) Customized shaft end machining is also available.

Screw O.D.	10
Lead	2
Overall length	~ 400mm
Grade	C3 or C5

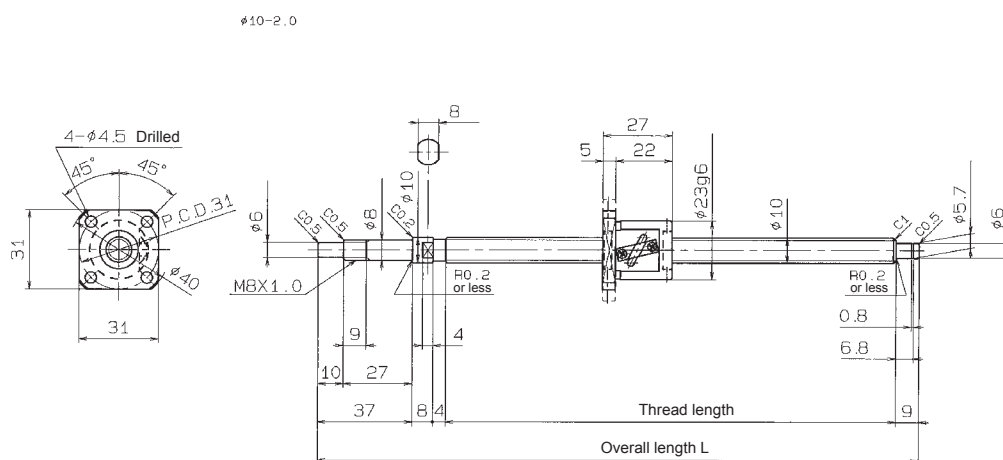

Unit (mm)

P/N	Axial clearance	Screw O.D. <i>d</i>	Lead <i>ℓ</i>	Overall length <i>L</i>	Ball dia. <i>Da</i>	Ball circle dia. <i>dm</i>	Screw root dia. <i>dr</i>	Number of turns & circuits Turns×Circ.	Basic rated load (daN)		Stiffness (daN/μm) <i>K</i>	Torque (daN·cm)
									Dynamic <i>Ca</i>	Static <i>Coa</i>		
BS1002-250	0	10	2	250 or less	1.588	10.3	8.6	2.5×1	130	180	8.4	0.02 ~ 0.20
	0.005 or less								200	360	9.4	—
BS1002-400	0	10	2	400 or less	1.588	10.3	8.6	2.5×1	130	180	8.4	0.02 ~ 0.20
	0.005 or less								200	360	9.4	—

# 12. SHAFT END MACHINING SERIES

- (1) Attached drawing shows Sankyo standard shaft end specification.
- (2) Customized shaft end machining is also available.

Screw O.D.	10
Lead	4
Overall length	~ 455mm
Grade	C3 or C5

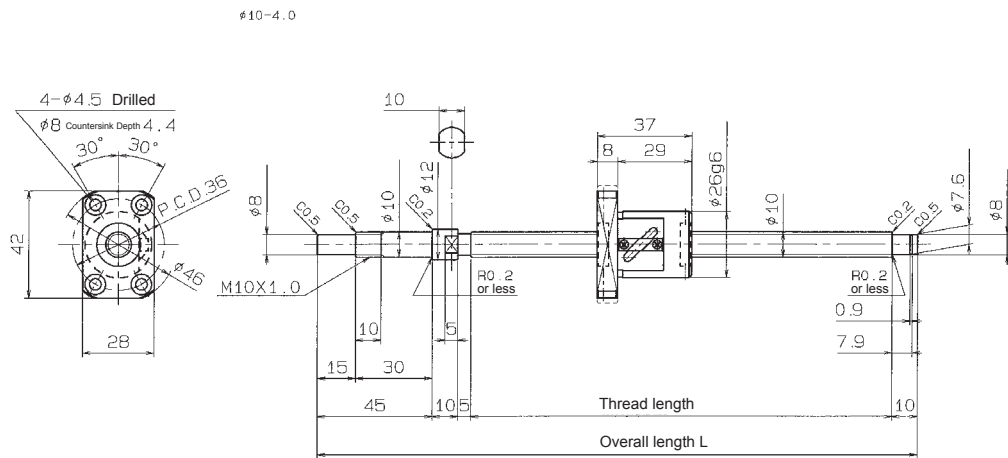

Unit (mm)

P/N	Axial clearance	Screw O.D. $d$	Lead $\ell$	Overall length $L$	Ball dia. $Da$	Ball circle dia. $dm$	Screw root dia. $dr$	Number of turns & circuits Turns×Circ.	Basic rated load (daN)		Stiffness (daN/μm) $K$	Torque (daN·cm)
									Dynamic $Ca$	Static $Coa$		
BS1004-250	0	10	4	250 or less	2.000	10.3	8.2	2.5×1	170	225	8.3	0.02 ~ 0.20
	0.005 or less								275	445	9.8	—
BS1004-455	0	10	4	455 or less	2.000	10.3	8.2	2.5×1	170	225	8.3	0.02 ~ 0.20
	0.005 or less								275	445	9.8	—



- (1) Attached drawing shows Sankyo standard shaft end specification.  
 (2) Customized shaft end machining is also available.

Screw O.D.	10
Lead	10
Overall length	~ 500mm
Grade	C3 or C5

#10-10.0

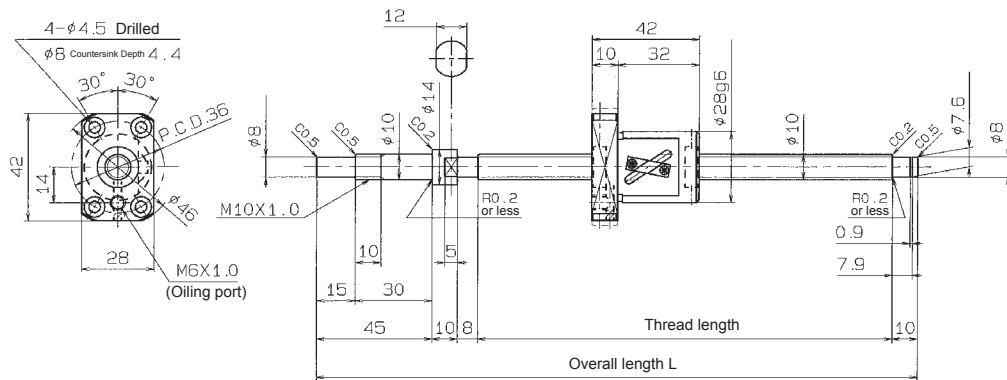

Unit (mm)

P/N	Axial clearance	Screw O.D. <i>d</i>	Lead <i>ℓ</i>	Overall length <i>L</i>	Ball dia. <i>Da</i>	Ball circle dia. <i>dm</i>	Screw root dia. <i>dr</i>	Number of turns & circuits Turns×Circ.	Basic rated load (daN)		Stiffness (daN/μm) <i>K</i>	Torque (daN·cm)
									Dynamic <i>Ca</i>	Static <i>Coa</i>		
BS1010-255	0	10	10	255 or less	2.000	10.3	8.2	1.5×1	110	130	5.3	0.02 ~ 0.20
	0.005 or less								175	265	5.9	—
BS1010-500	0	10	10	500 or less	2.000	10.3	8.2	1.5×1	110	130	5.3	0.02 ~ 0.20
	0.005 or less								175	265	5.9	—

# 12. SHAFT END MACHINING SERIES

- (1) Attached drawing shows Sankyo standard shaft end specification.
- (2) Customized shaft end machining is also available.

Screw O.D.	12
Lead	2
Overall length	~ 400mm
Grade	C3 or C5

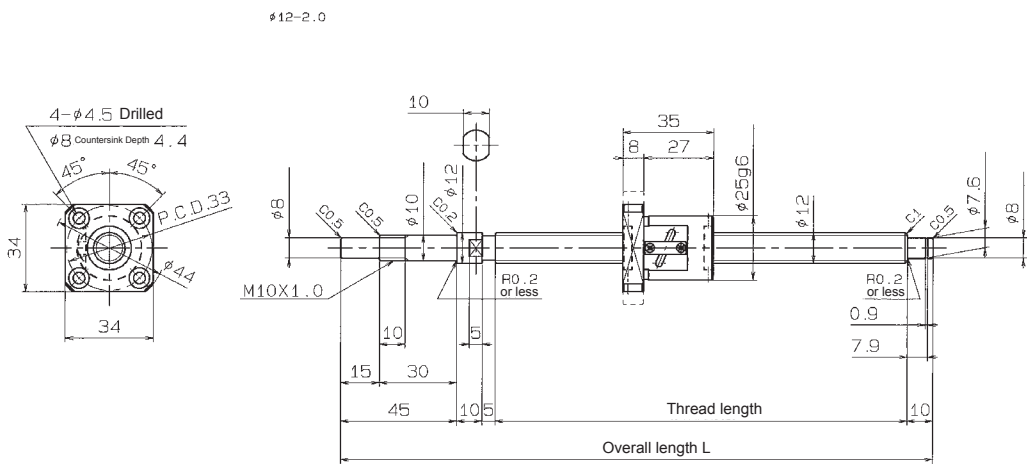

Unit (mm)

P/N	Axial clearance	Screw O.D.	Lead	Overall length	Ball dia.	Ball circle dia.	Screw root dia.	Number of turns & circuits Turns×Circ.	Basic rated load (daN)		Stiffness (daN/μm)	Torque (daN·cm)
		<i>d</i>	<i>ℓ</i>	L	Da	dm	dr		Dynamic Ca	Static Coa	K	
BS1202-400	0	12	2	400 or less	1.588	12.3	10.6	2.5×1	140	220	9.8	0.04 ~ 0.30
	0.005 or less								220	435	11	—

- (1) Attached drawing shows Sankyo standard shaft end specification.
- (2) Customized shaft end machining is also available.

Screw O.D.	12
Lead	4
Overall length	~ 600mm
Grade	C3 or C5

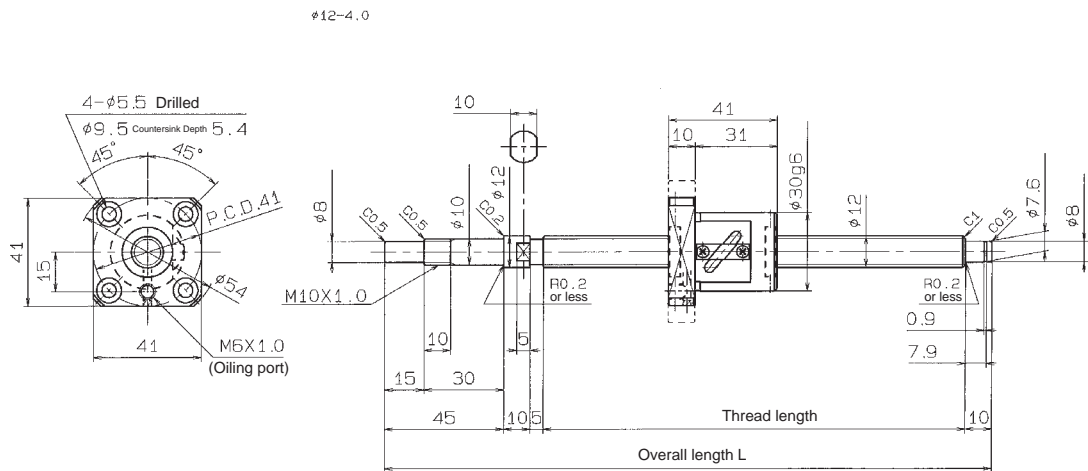

Unit (mm)

P/N	Axial clearance	Screw O.D. $\ell$	Lead $\ell$	Overall length L	Ball dia. Da	Ball circle dia. dm	Screw root dia. dr	Number of turns & circuits Turns×Circ.	Basic rated load (daN)		Stiffness (daN/μm) K	Torque (daN·cm)
									Dynamic Ca	Static Coa		
BS1204-405	0	12	4	405 or less	2.381	12.3	9.8	2.5×1	235	320	9.8	0.10 ~ 0.40
	0.005 or less								375	635	12	—
BS1204-600	0	12	4	600 or less	2.381	12.3	9.8	2.5×1	235	320	9.8	0.10 ~ 0.40
	0.005 or less								375	635	12	—

# 12. SHAFT END MACHINING SERIES

- (1) Attached drawing shows Sankyo standard shaft end specification.
- (2) Customized shaft end machining is also available.

Screw O.D.	12
Lead	5
Overall length	~ 455mm
Grade	C3 or C5

#12-5.0

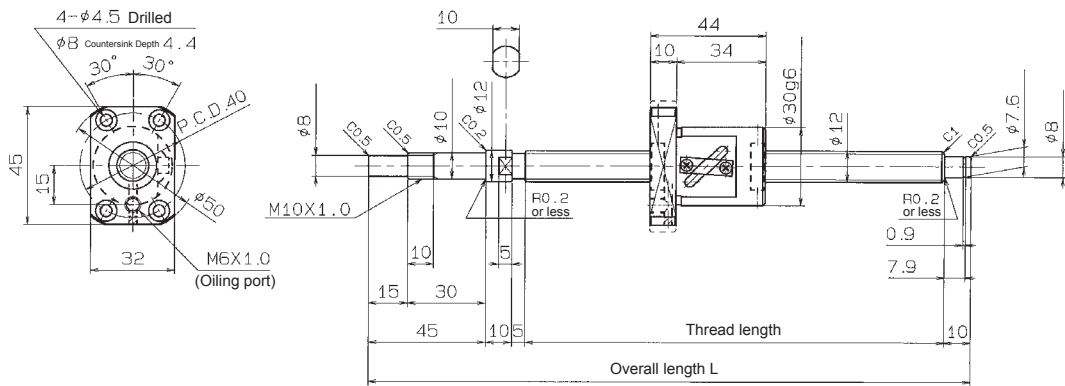

Unit (mm)

P/N	Axial clearance	Screw O.D. <i>d</i>	Lead <i>ℓ</i>	Overall length <i>L</i>	Ball dia. <i>Da</i>	Ball circle dia. <i>dm</i>	Screw root dia. <i>dr</i>	Number of turns & circuits Turns×Circ.	Basic rated load (daN)		Stiffness (daN/μm) <i>K</i>	Torque (daN·cm)
									Dynamic <i>Ca</i>	Static <i>Coa</i>		
BS1205-300	0	12	5	300 or less	2.381	12.3	9.8	2.5×1	235	320	9.8	0.10 ~ 0.40
	0.005 or less								375	635	12	—
BS1205-455	0	12	5	455 or less	2.381	12.3	9.8	2.5×1	235	320	9.8	0.10 ~ 0.40
	0.005 or less								375	635	12	—

- (1) Attached drawing shows Sankyo standard shaft end specification.
- (2) Customized shaft end machining is also available.

Screw O.D.	12
Lead	10
Overall length	~ 600mm
Grade	C3 or C5

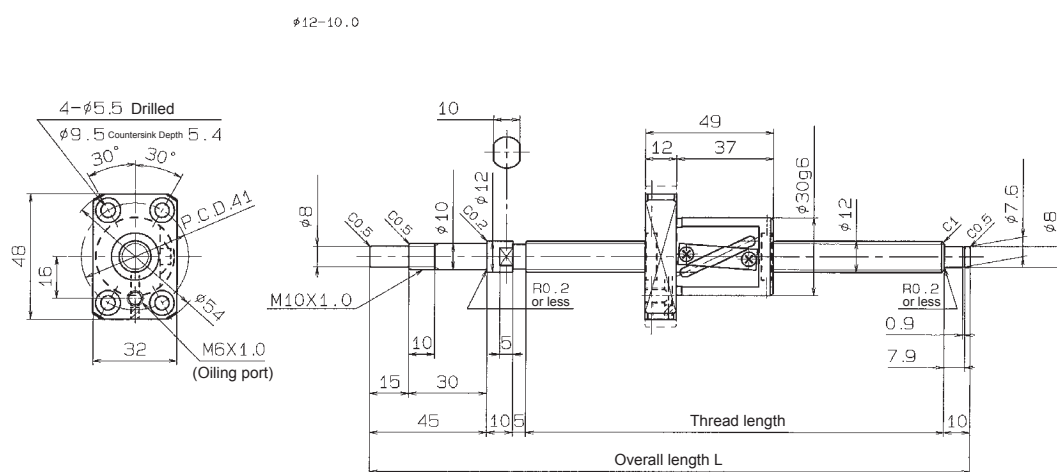

Unit (mm)

P/N	Axial clearance	Screw O.D. <i>d</i>	Lead <i>ℓ</i>	Overall length <i>L</i>	Ball dia. <i>Da</i>	Ball circle dia. <i>dm</i>	Screw root dia. <i>dr</i>	Number of turns & circuits Turns×Circ.	Basic rated load (daN)		Stiffness (daN/μm) <i>K</i>	Torque (daN·cm)
									Dynamic <i>Ca</i>	Static <i>Coa</i>		
BS1210-300	0	12	10	300 or less	2.381	12.5	9.8	2.5×1	240	315	10	0.10 ~ 0.50
	0.005 or less								380	630	12	—
BS1210-455	0	12	10	455 or less	2.381	12.5	9.8	2.5×1	240	315	10	0.10 ~ 0.50
	0.005 or less								380	630	12	—
BS1210-600	0	12	10	600 or less	2.381	12.5	9.8	2.5×1	240	315	10	0.10 ~ 0.50
	0.005 or less								380	630	12	—

# 12. SHAFT END MACHINING SERIES

- (1) Attached drawing shows Sankyo standard shaft end specification.
- (2) Customized shaft end machining is also available.

Screw O.D.	15
Lead	5
Overall length	~ 600mm
Grade	C3 or C5

φ12-20.0

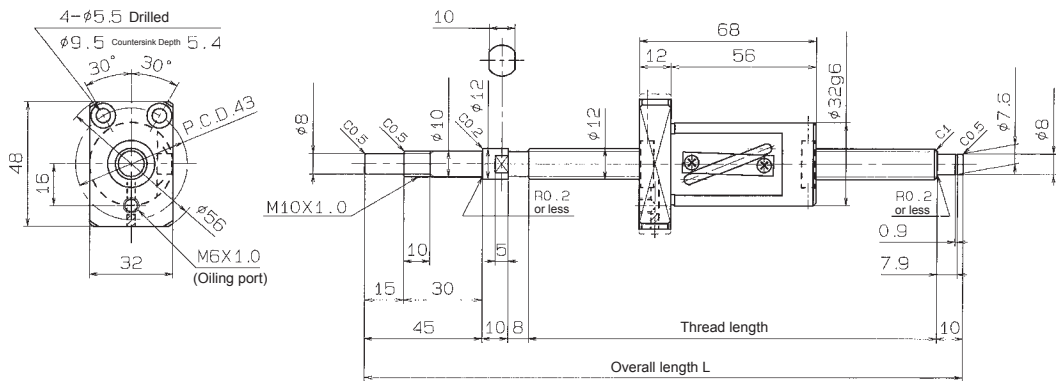

Unit (mm)

P/N	Axial clearance	Screw O.D. <i>d</i>	Lead <i>ℓ</i>	Overall length <i>L</i>	Ball dia. <i>Da</i>	Ball circle dia. <i>dm</i>	Screw root dia. <i>dr</i>	Number of turns & circuits Turns×Circ.	Basic rated load (daN)		Stiffness (daN/μm) <i>K</i>	Torque (daN·cm)
									Dynamic <i>Ca</i>	Static <i>Coa</i>		
BS1220-400	0	12	20	400 or less	2.381	12.5	9.8	1.5×1	150	175	6.1	0.10 ~ 0.50
	0.005 or less								240	350	7.1	—
BS1220-600	0	12	20	600 or less	2.381	12.5	9.8	1.5×1	150	175	6.1	0.10 ~ 0.50
	0.005 or less								240	350	7.1	—







- (1) Attached drawing shows Sankyo standard shaft end specification.
- (2) Customized shaft end machining is also available.

Screw O.D.	15
Lead	10
Overall length	~ 1100mm
Grade	C3 or C5

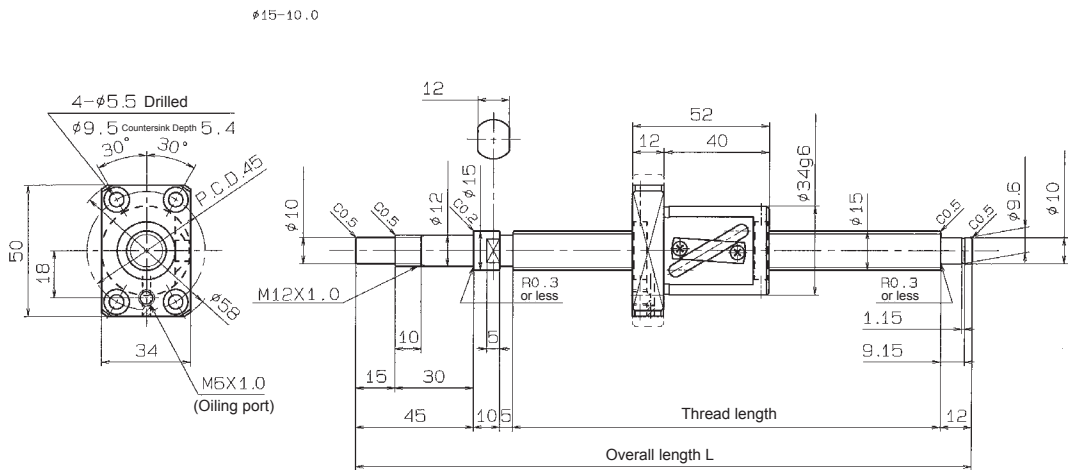

Unit (mm)

P/N	Axial clearance	Screw O.D. <i>d</i>	Lead <i>ℓ</i>	Overall length <i>L</i>	Ball dia. <i>Da</i>	Ball circle dia. <i>dm</i>	Screw root dia. <i>dr</i>	Number of turns & circuits Turns×Circ.	Basic rated load (daN)		Stiffness (daN/μm) <i>K</i>	Torque (daN·cm)
									Dynamic <i>Ca</i>	Static <i>Coa</i>		
BS1510-450	0	15	10	450 or less	3.175	15.5	12.2	2.5×1	445	630	13	0.10 ~ 0.50
	0.005 or less								710	1260	15	—
BS1510-600	0	15	10	600 or less	3.175	15.5	12.2	2.5×1	445	630	13	0.10 ~ 0.60
	0.005 or less								710	1260	15	—
BS1510-1100	0	15	10	1100 or less	3.175	15.5	12.2	2.5×1	445	630	13	0.10 ~ 0.70
	0.005 or less								710	1260	15	—





# 12. SHAFT END MACHINING SERIES

- (1) Attached drawing shows Sankyo standard shaft end specification.
- (2) Customized shaft end machining is also available.

Screw O.D.	20
Lead	5
Overall length	~ 1100mm
Grade	C3 or C5

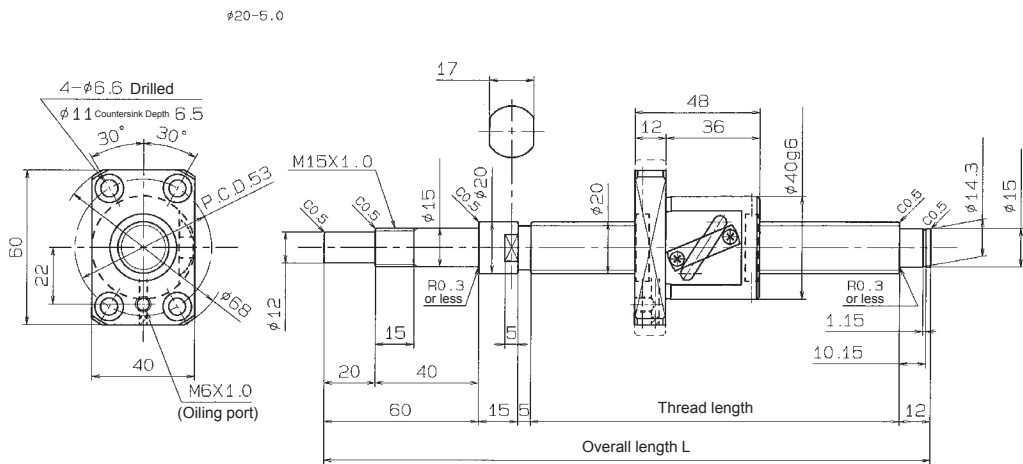

Unit (mm)

P/N	Axial clearance	Screw O.D. <i>d</i>	Lead <i>ℓ</i>	Overall length <i>L</i>	Ball dia. <i>Da</i>	Ball circle dia. <i>dm</i>	Screw root dia. <i>dr</i>	Number of turns & circuits Turns×Circ.	Basic rated load (daN)		Stiffness (daN/μm) <i>K</i>	Torque (daN·cm)
									Dynamic <i>Ca</i>	Static <i>Coa</i>		
BS2005-600	0	20	5	600 or less	3.175	20.5	17.2	2.5×1	520	865	16	0.20 ~ 0.54
	0.005 or less								820	1730	19	—
BS2005-1100	0	20	5	1100 or less	3.175	20.5	17.2	2.5×1	520	865	16	0.09 ~ 0.65
	0.005 or less								820	1730	19	—

- (1) Attached drawing shows Sankyo standard shaft end specification.
- (2) Customized shaft end machining is also available.

Screw O.D.	20
Lead	10
Overall length	~ 1100mm
Grade	C3 or C5

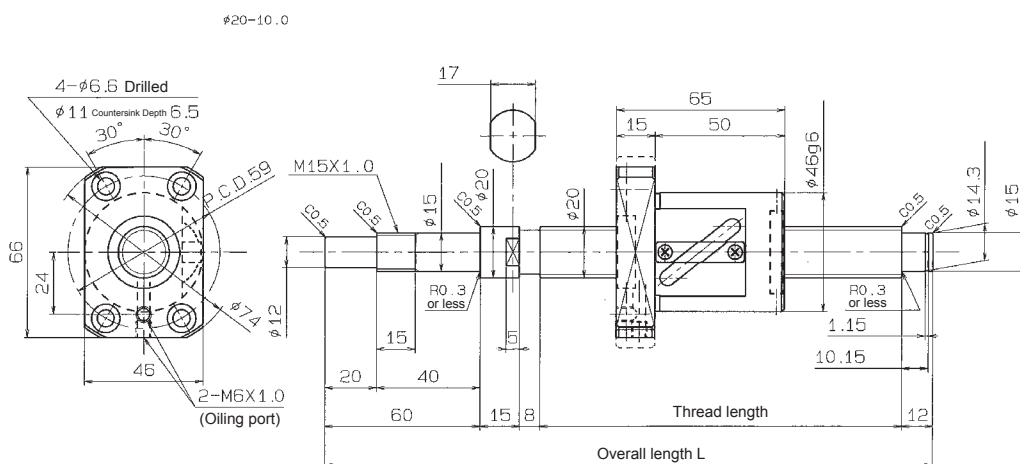

Unit (mm)

P/N	Axial clearance	Screw O.D. <i>d</i>	Lead <i>ℓ</i>	Overall length <i>L</i>	Ball dia. <i>Da</i>	Ball circle dia. <i>dm</i>	Screw root dia. <i>dr</i>	Number of turns & circuits Turns×Circ.	Basic rated load (daN)		Stiffness (daN/μm) <i>K</i>	Torque (daN·cm)
									Dynamic <i>Ca</i>	Static <i>Coa</i>		
BS2010-600	0	20	10	600 or less	3.969	21	16.3	2.5×1	700	1085	17	0.39 ~ 1.04
	0.005 or less								1110	2170	20	—
BS2010-1100	0	20	10	600 or less	3.969	21	16.3	2.5×1	700	1085	17	0.18 ~ 1.25
	0.005 or less								1110	2170	20	—

# 12. SHAFT END MACHINING SERIES

- (1) Attached drawing shows Sankyo standard shaft end specification.
- (2) Customized shaft end machining is also available.

Screw O.D.	20
Lead	20
Overall length	~ 1100mm
Grade	C3 or C5

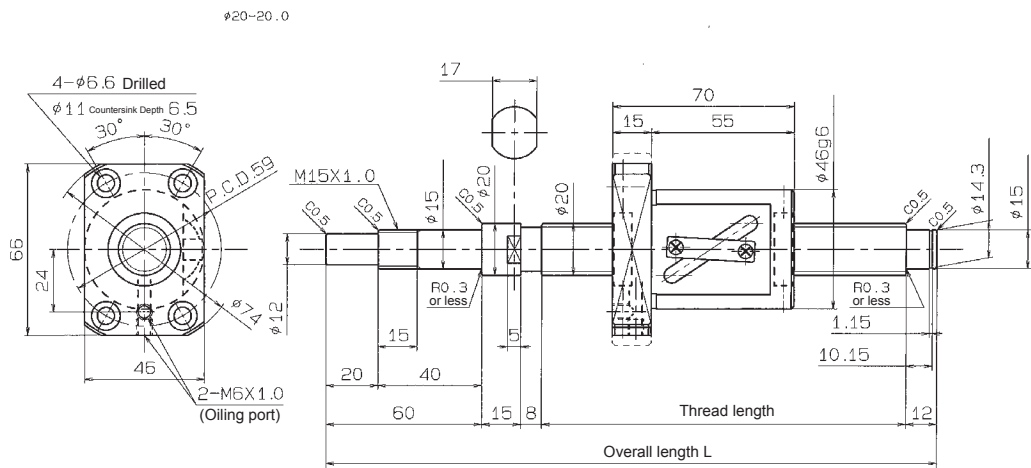

Unit (mm)

P/N	Axial clearance	Screw O.D. <i>d</i>	Lead <i>ℓ</i>	Overall length <i>L</i>	Ball dia. <i>Da</i>	Ball circle dia. <i>dm</i>	Screw root dia. <i>dr</i>	Number of turns & circuits Turns×Circ.	Basic rated load (daN)		Stiffness (daN/μm) <i>K</i>	Torque (daN·cm)
									Dynamic <i>Ca</i>	Static <i>Coa</i>		
BS2020-600	0	20	20	600 or less	3.969	21	16.3	1.5×1	445	630	10	0.35 ~ 0.92
	0.005 or less								705	1260	12	—
BS2020-1100	0	20	20	1100 or less	3.969	21	16.3	1.5×1	445	630	18	0.16 ~ 1.11
	0.005 or less								705	1260	24	—

- (1) Attached drawing shows Sankyo standard shaft end specification.  
 (2) Customized shaft end machining is also available.

Screw O.D.	25
Lead	5
Overall length	~ 1100mm
Grade	C3 or C5

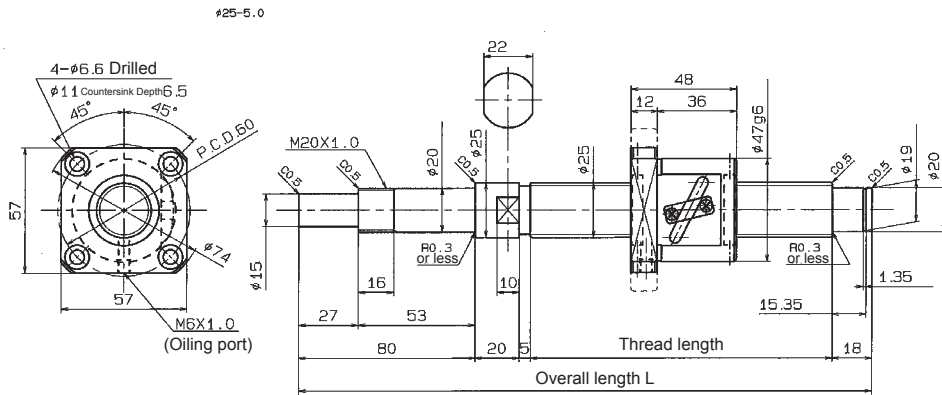

Unit (mm)

P/N	Axial clearance	Screw O.D.	Lead	Overall length	Ball dia.	Ball circle dia.	Screw root dia.	Number of turns & circuits	Basic rated load (daN)		Stiffness (daN/μm)	Torque (daN·cm)
		<i>d</i>							<i>ℓ</i>	L		
BS2505-600	0	25	5	600 or less	3.175	25.5	22.2	2.5×1	575	1090	20	0.14 ~ 0.79
	0.005 or less								910	2180	23	—
BS2505-1100	0	25	5	1100 or less	3.175	25.5	22.2	2.5×1	575	1090	20	0.07 ~ 0.86
	0.005 or less								910	2180	23	—

# 12. SHAFT END MACHINING SERIES

- (1) Attached drawing shows Sankyo standard shaft end specification.
- (2) Customized shaft end machining is also available.

Screw O.D.	25
Lead	10
Overall length	~ 1100mm
Grade	C3 or C5

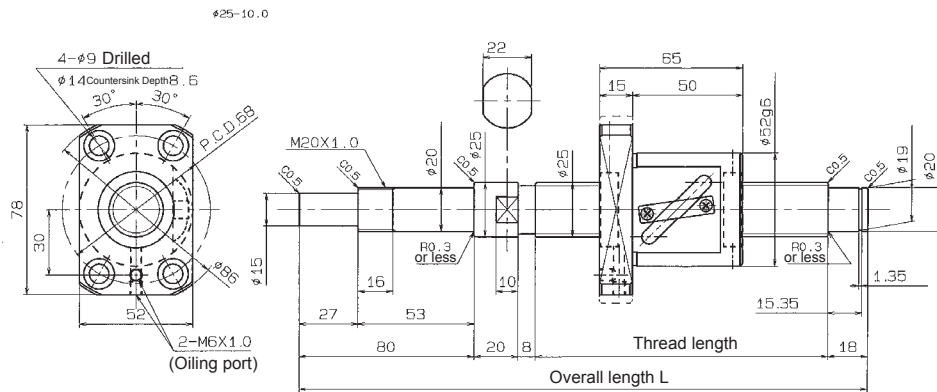

Unit (mm)

P/N	Axial clearance	Screw O.D. <i>d</i>	Lead <i>ℓ</i>	Overall length <i>L</i>	Ball dia. <i>Da</i>	Ball circle dia. <i>dm</i>	Screw root dia. <i>dr</i>	Number of turns & circuits Turns×Circ.	Basic rated load (daN)		Stiffness (daN/μm) <i>K</i>	Torque (daN·cm)
									Dynamic <i>Ca</i>	Static <i>Coa</i>		
BS2510-600	0	25	20	600 or less	3.969	26	21.3	2.5×1	495	820	18	0.17 ~ 0.97
	0.005 or less								1240	2740	24	—
BS2510-1100	0	25	20	1100 or less	3.969	26	21.3	2.5×1	495	820	18	0.09 ~ 1.05
	0.005 or less								1240	2740	24	—



- (1) Attached drawing shows Sankyo standard shaft end specification.  
 (2) Customized shaft end machining is also available.

Screw O.D.	25
Lead	20
Overall length	~ 1100mm
Grade	C3 or C5

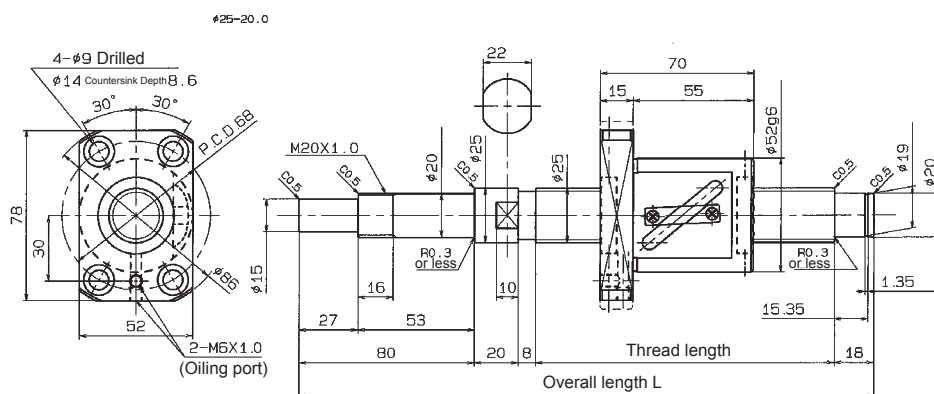

Unit (mm)

P/N	Axial clearance	Screw O.D. <i>d</i>	Lead <i>ℓ</i>	Overall length <i>L</i>	Ball dia. <i>Da</i>	Ball circle dia. <i>dm</i>	Screw root dia. <i>dr</i>	Number of turns & circuits Turns×Circ.	Basic rated load (daN)		Stiffness (daN/μm) <i>K</i>	Torque (daN·cm)
									Dynamic <i>Ca</i>	Static <i>Coa</i>		
BS2520-1100	0	25	20	1100 or less	3.969	26	21.3	1.5×1	495	805	13	0.12 ~ 1.49
	0.005 or less								790	1610	14	—

## 13. MANUFACTURING, ASSEMBLING & INSPECTION FACILITIES



Precision Long Size Thread Grinding Machine

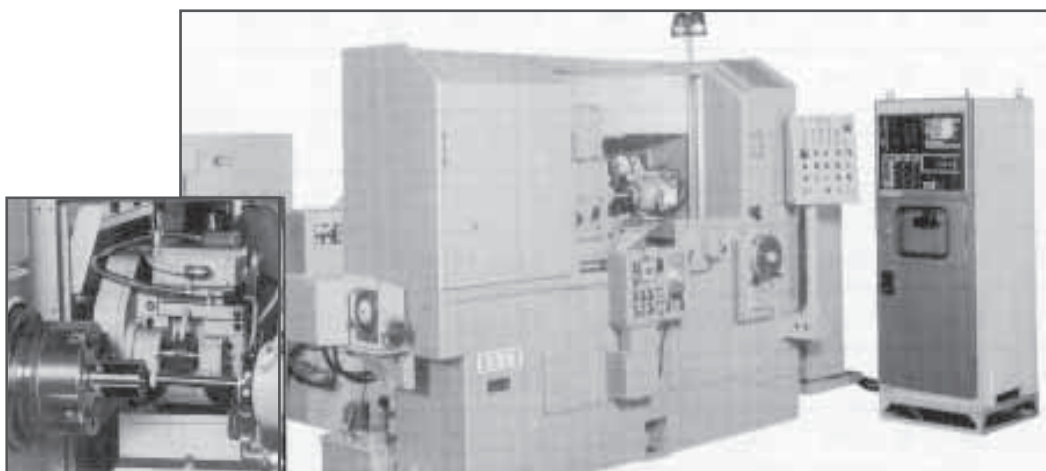

Grinding of Thread Groove of Nut



Laser Type Screw Lead Automatic Measuring Machine

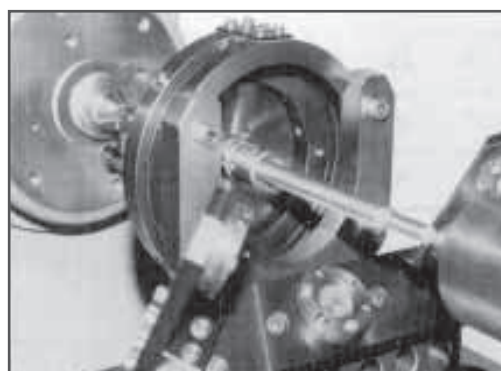

Application Example: Measurement of Lead and Nut Assembly (PAT.)

# 14. HANDLING PRECAUTIONS FOR BALL SCREWS

**As Ball Screws are precision parts, carefully handle them by referring to the following instructions:**

## **Lubrication**

1. Thoroughly check the lubricant condition before use.  
Improper lubrication will shorten the service life of Ball Screw.
2. When lubricating grease is applied to Ball Screw, use the Ball Screw directly.  
However, if dust and chips accumulate on the surface of grease coating, clean it with pure kerosene or degrease, and then apply new lubricating grease of the same type as coated on the Ball Screw before use.  
When degreasing Ball Screw, avoid using organic solvent which may melt acrylic adhesives.
3. Check the grease 2 to 3 months after Ball Screw is used for the first time. If the grease is extremely dirty, wipe off old grease and apply a sufficient amount of new grease. Thereafter, check and replenish every year, but perform periodic check and maintenance according to operating conditions for the Ball Screw.

## **Handling**

1. Never disassemble Ball Screw. Other wise, dust may enter it, resulting in an accident and degrading accuracy.
2. Avoid reassembling Ball Screw on the user side. Otherwise the function of the Ball Screw may be lost due to incorrect assembling. Send the Ball Screw to our company for repair and reassembly at your expense.
3. As Ball Screw or Nut may sometimes drop spontaneously, be careful not to get hurt. If Ball Screw drops, its function may be lost due to a damage to the circulating parts etc.  
In this case, the Ball Screw should be checked by our company.  
Be sure to send it to our company for check and repair at your expense.
4. When Ball Screw drops, the circulating parts, shaft outside surface, ball groove, etc, may be flawed or scratched.

## **Operating Precautions**

1. Use Ball Screw in a clean environment. Prevent dust and chips from entering Ball Screw by using a dustproof cover. Dust and chips which enter Ball Screw due to insufficient dustproofing may adversely affect the performance of the Ball Screw, causing to lock it or damage the circulating parts or sometimes drop the table.
2. For operating speed of Ball Screw, refer to "Permissible Operating Speed" given in Sankyo BALL SCREW CATALOG or specifications and drawings supplied by our company.  
If the permissible operating speed is exceeded during operation, the circulating parts may be damaged, sometimes resulting in a lock or an accidental drop of the table.  
When Ball Screw is mounted on a vertical axis, it is recommended that safety nuts or drop prevention be provided. For details of a safety device, contact our company.
3. If Ball Screw Nut is overrun, the ball may drop, the circulating part may be damaged or the ball groove may dent, causing a malfunction.  
Be careful not to overrun Ball Screw without fail.  
If your Ball Screw is overrun, contact our company. We will check it or take proper countermeasures at your expense.
4. The operating temperature limit is usually set at less than 80 °C. Avoid operating Ball Screw at higher temperature than the temperature limit. Otherwise, the circulating parts and sealing parts may be damaged.

## **Storage**

1. When storing Ball Screw, keep it in the original package supplied by our company. Do not unpack or tear the package except in case of need. Otherwise, dust may enter Ball Screw, resulting in resting and deterioration of the performance.
2. It is recommendable to store Ball Screw as follows;
  - (1) Place it horizontally in the original package supplied by our company.
  - (2) Put a sleeper on Ball Screw and place them horizontally in a clean place.
  - (3) Suspend Ball Screw in a clean place.

# Sankyo Precision Ball Screw Ordering Information

**Name:**

**Title:**

**Company Name:**

**Company Address:**

**Name of machine in use:**

**Drawing or sketch: Attached**

Not attached (Draw rough sketch below.)

## 1. Loading conditions

1-1 Max. axial load \_\_\_\_\_ N      No. of rev. \_\_\_\_\_ rpm      Operating ratio \_\_\_\_\_ %  
 Normal axial load \_\_\_\_\_ N      No. of rev. \_\_\_\_\_ rpm      Operating ratio \_\_\_\_\_ %  
 Min. axial load \_\_\_\_\_ N      No. of rev. \_\_\_\_\_ rpm      Operating ratio \_\_\_\_\_ %  
 1-2 Max. axial static load \_\_\_\_\_ N      Total \_\_\_\_\_ %  
 1-3 Existence of one-side load (Avoid if possible.)  
 No. \_\_\_\_\_ Yes \_\_\_\_\_      Moment load \_\_\_\_\_ N·m      Radial load \_\_\_\_\_ N

## 2. Installation

2-1 Supported length \_\_\_\_\_ mm      Supporting method \_\_\_\_\_

## 3. Operating conditions

3-1 Max. stroke \_\_\_\_\_ mm  
 3-2 Life required \_\_\_\_\_ hr.      km \_\_\_\_\_ × 10rev  
 3-3 Shaft rotation \_\_\_\_\_      Nut rotation \_\_\_\_\_  
 3-4 Shockless smooth operation \_\_\_\_\_      Ordinary operation \_\_\_\_\_      Vibratory operation \_\_\_\_\_

## 4. Dimensions

4-1 Nominal shaft outside diameter \_\_\_\_\_ mm  
 4-2 Nominal lead \_\_\_\_\_ mm (Pitch \_\_\_\_\_ mm)      Right-hand thread      Left-hand thread \_\_\_\_\_  
 4-3 Overall shaft length \_\_\_\_\_ mm      Effective thread length \_\_\_\_\_ mm  
 4-4 Nut type \_\_\_\_\_      Flange configuration \_\_\_\_\_  
 4-5 Seal      Provided \_\_\_\_\_      Not provided \_\_\_\_\_

## 5. Lead accuracy

5-1 Target value of specified travel \_\_\_\_\_ mm  
 5-2 Grade symbol \_\_\_\_\_

## 6. Axial clearance, preload and stiffness

6-1 Existence of axial clearance      Yes \_\_\_\_\_ mm Max.      No. \_\_\_\_\_  
 6-2 Amount of preload \_\_\_\_\_ N      Torque required \_\_\_\_\_ N·m  
 Stiffness of Nut K \_\_\_\_\_ N·m

## 7. Operating conditions

7-1 Lubrication      Grease \_\_\_\_\_      Oil \_\_\_\_\_  
 7-2 Dustproof cover \_\_\_\_\_  
 7-3 Operating temperature \_\_\_\_\_ °C  
 7-4 Corrosion prevention      Required \_\_\_\_\_      Not required \_\_\_\_\_      Material \_\_\_\_\_      Surface treatment \_\_\_\_\_

## 8. Quantities

8-1 Set per unit  
 8-2 Scheduled date of trial manufacture \_\_\_\_\_  
 8-3 Scheduled date of mass-production \_\_\_\_\_      Q' ty/lot \_\_\_\_\_

9. Rough sketch \_\_\_\_\_ Sheets