

GEM-FLOW | G500-EL

Electric Solenoid Control Valve 1-1/2" - 4"

Description

G500-EL model valve is the hydraulic control valve operated by line pressure and designed to ensure opening/closing process by means of built-in 3 Way solenoid pilot valve controlled remotely with electric signal*. Electric signal for solenoid pilot valve is ensured by means of a control device, time relay, main switch and PLC control units etc. Opening/Closing process may be realized easily thanks to manual control on solenoid pilot valve, depending on requirements, 24V AC 50Hz/60Hz or 12V DC, 9V Latch and 12V DC Latch normally open (NO) or normally closed (NC), solenoids coils may be used on main valve.

* For technical information, refer to G75-A and G75-A3P solenoid valves

Applications

- Use G500-EL to remove operation of hydraulic valve by an electric command
- Use G500-EL for water distribution

Standards

- G500-EL: 3 Way NO Solenoid, polyethylene plastic tubing system and nylon fittings
- G500-ELM: 3 Way NO Solenoid, polyethylene plastic tubing system, nylon fittings and 3 Way selector

How to Order

G500	-	TYPE	-	PORT	VOLTAGE		WIRES	
		Electric	EL	1-1/2" BSPT	70	No solenoid (hydraulic)	0	two null
		with Manual Selector	ELM	1-1/2" NPT	71	24V AC	1	three ⁽²⁾ a
				2" BSPT	80	24V AC w/out Diode	1R	
				2" NPT	81	12V AC	3	
				2-1/2" BSPT	85	12V DC	4	
				2-1/2" NPT	86	24V DC	5	
				3" BSPT	90	23Ω	6	
				3" NPT	91	4Ω	B	
				4" BSPT	100	9Ω	C	
				4" NPT	101	12Ω	D	
				4" Flange	100F	1Ω ⁽¹⁾	PA	
						4Ω ⁽¹⁾	PB	
						9Ω ⁽¹⁾	PC	

Example: G500-ELM-801

G500 Electric with manual selector, 2" BSPT, 24V AC, two wires

G500 - ELM - 80 - 1

- (1) For G75-A3P Latch
(2) For Latch only

* To order valves manufactured according to your specific requirements, please contact our technical sales department

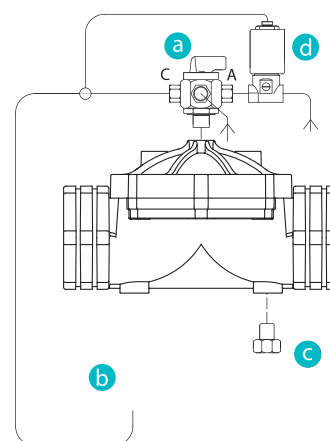

- a 3W selector valve
- b In-line finger filter
- c Plug
- d Solenoid Pilot Valve